

RAD-ISM-900-ANT-OMNI-FG-3-N - Antenna



2867791

<https://www.phoenixcontact.com/us/products/2867791>

Please be informed that the data shown in this PDF document is generated from our online catalog. Please find the complete data in the user documentation. Our general terms of use for downloads are valid.

Omnidirectional antenna, 900 MHz, gain: 5 dBi, polarization: linear, opening angle: h/v 360°/28°, degree of protection: IP65, connection: N (female), incl. mounting bracket and mast clips



Your advantages

- For freely mobile applications
- For multipoint or mesh connections

Commercial data

Item number	2867791
Packing unit	1 pc
Note	Made to order (non-returnable)
Sales key	DN23
Product key	DNC6A3
GTIN	4017918976705
Weight per piece (including packing)	444.44 g
Weight per piece (excluding packing)	444.44 g
Customs tariff number	85177000
Country of origin	US

2867791

<https://www.phoenixcontact.com/us/products/2867791>

Technical data

Product properties

Product type	Antenna
Gain	5.15 dBi
Vertical beamwidth	28 °
Horizontal beamwidth	360 °
Polarization	Linear vertical

Electrical properties

Frequency band	900 MHz
Frequency range	902 MHz ... 928 MHz
Impedance	50 Ω
Voltage standing wave ratio VSWR in a 50 Ω system	≤ 1.50

Connection data

Connection technology

Connection method	N (female)
Outside diameter	38 mm ... 60 mm (Mast)

Dimensions

Width	2.38 in.
Height	44.25 in.

External dimensions

Outside diameter	38 mm ... 60 mm (Mast)
------------------	------------------------

Material specifications

Material	Fiberglass-reinforced plastic
	V2A
	V2A

Cable/line

Connecting cable	no
------------------	----

Environmental and real-life conditions

Ambient conditions

Degree of protection	IP65
Ambient temperature (operation)	-40 °C ... 80 °C
Wind velocity	15.4321 km/h

Mounting

Mounting type	Mast mounting
---------------	---------------

Drawings

Schematic diagram

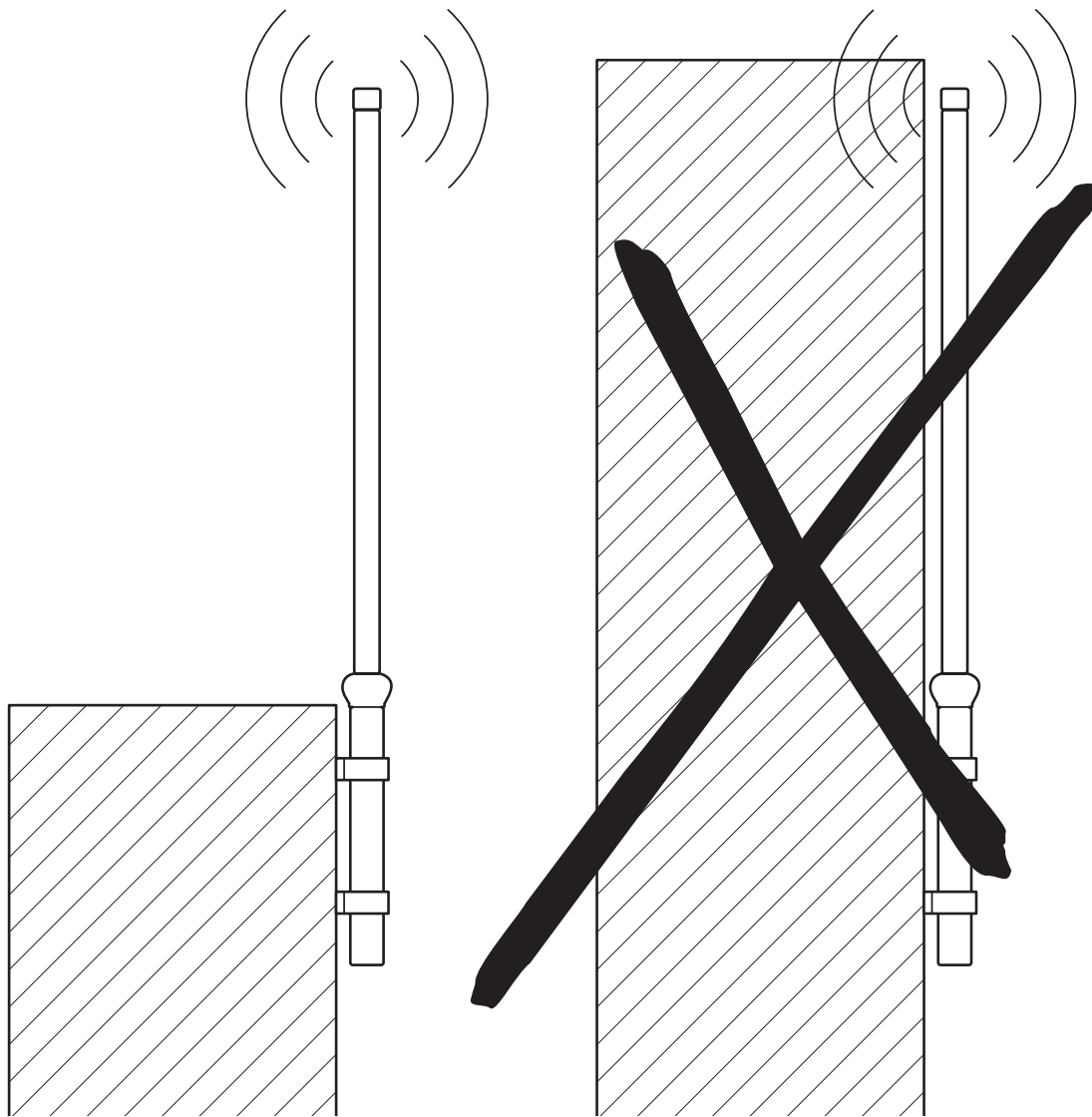

RAD-ISM-900-ANT-OMNI-FG-3-N - Antenna



2867791

<https://www.phoenixcontact.com/us/products/2867791>

Schematic diagram

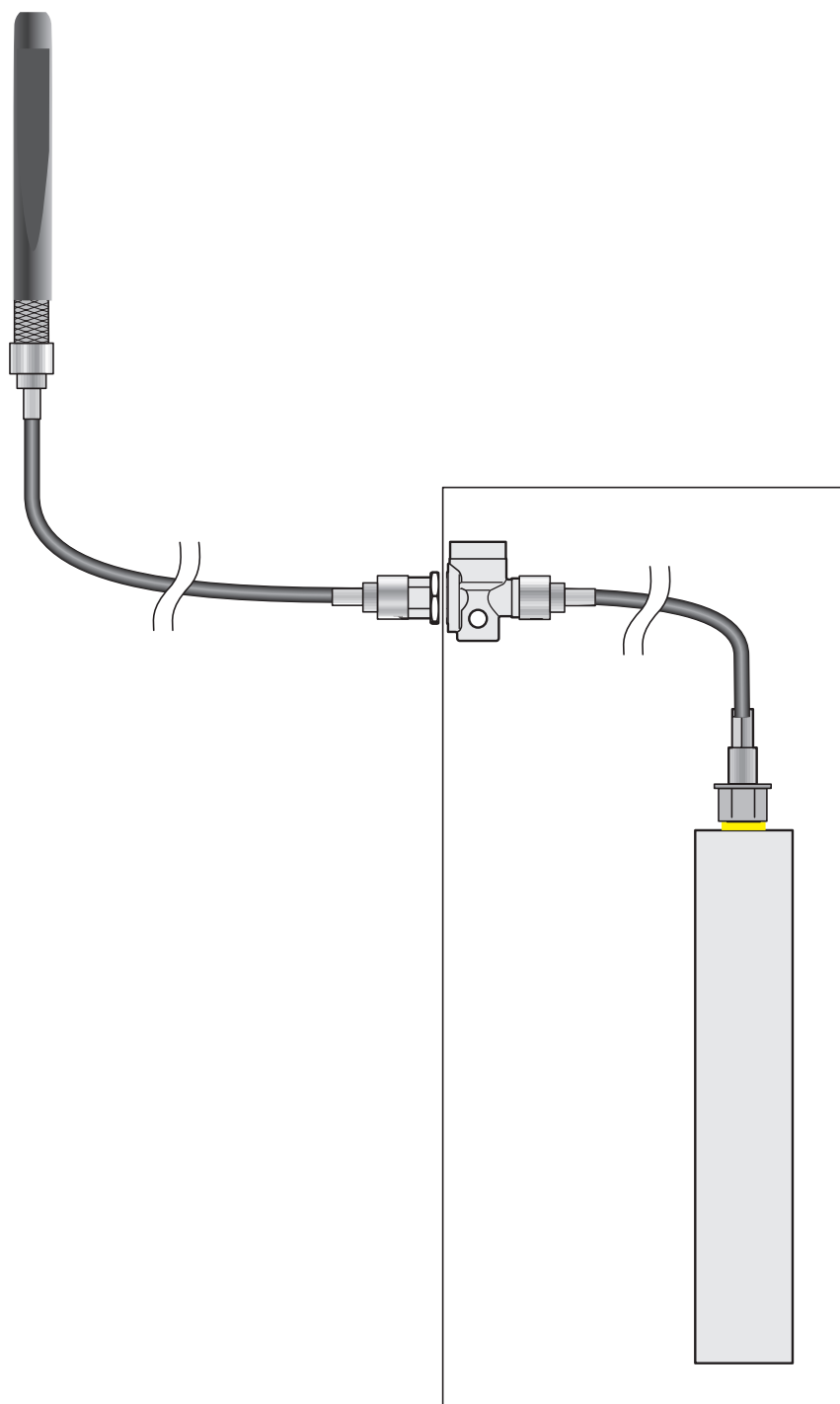

Installation example

RAD-ISM-900-ANT-OMNI-FG-3-N - Antenna



2867791

<https://www.phoenixcontact.com/us/products/2867791>

Classifications

UNSPSC

UNSPSC 21.0	43223100
-------------	----------

2867791

<https://www.phoenixcontact.com/us/products/2867791>

Environmental product compliance

EU RoHS

Fulfills EU RoHS substance requirements	Yes
Exemption	6(c)

China RoHS

Environment friendly use period (EFUP)	EFUP-50
	An article-related China RoHS declaration table can be found in the download area for the respective article under "Manufacturer declaration". For all articles with EFUP-E, no China RoHS declaration table issued and required.

EU REACH SVHC

REACH candidate substance (CAS No.)	Lead(CAS: 7439-92-1)
SCIP	6e3525a7-4434-4ae9-8ab5-bddfb7f53eda

Phoenix Contact 2026 © - all rights reserved

<https://www.phoenixcontact.com>

Phoenix Contact USA
586 Fulling Mill Road
Middletown, PA 17057, United States
(+717) 944-1300
info@phoenixcon.com