

RAD-ISM-900-BD-BUS - Wireless module



2867092

<https://www.phoenixcontact.com/us/products/2867092>

Please be informed that the data shown in this PDF document is generated from our online catalog. Please find the complete data in the user documentation. Our general terms of use for downloads are valid.



Transceiver (transmitter and receiver) for expanding point to multipoint connections and repeater circuits, for 900 MHz bidirectional wireless transmission system (America)

Your advantages

- The integrated bus foot enables connection to additional I/O modules
- Each transceiver has 1 analog input (4 ... 20 mA) and 2 digital inputs (5 ... 30 V AC/DC), as well as 1 analog output and 2 digital outputs, for direct connection to compatible sensors and actuators and for data transmission in both directions
- Frequency hopping spread spectrum
- Status of the wireless connection via a relay (RF link)
- Individual transceivers are listed under Class I, Division 2
- Operates in the license-free 902 MHz ... 928 MHz ISM band
- Two omnidirectional antennas (optional)
- Additional transceivers can be added to configure repeater systems
- No additional parameterization or programming required

Commercial data

Item number	2867092
Packing unit	1 pc
Note	Made to order (non-returnable)
Sales key	DN26
Product key	DNC651
GTIN	4017918929619
Weight per piece (including packing)	228.4 g
Weight per piece (excluding packing)	228.4 g
Customs tariff number	85176200
Country of origin	CA

Technical data

Product properties

Product type	Wireless module
--------------	-----------------

Electrical properties

Supply

Supply voltage	24 V DC
Supply voltage range	9 V DC ... 30 V DC
Typical current consumption	75 mA
Max. current consumption	200 mA

Input data

Digital

Input voltage range	5 V AC/DC ... 30 V AC/DC
Switching threshold "0" signal, voltage	max. 1.5 V DC
Switching threshold "1" signal voltage	min. 5 V DC

Analog

Description of the input	Current input (analog input)
Current input signal	4 mA ... 20 mA
Input resistance current input	< 170 Ω

Analog

Description of the input	Voltage input (digital input)
--------------------------	-------------------------------

Output data

Digital

Output name	2x relay output + 1 x RF link
Number of outputs	3
Contact switching type	3 floating N/O contacts
Contact material	Ag, gold-plated
Maximum switching voltage	30 V DC
	250 V AC
Limiting continuous current	2 A

Analog

Output name	Current output
Number of outputs	1
Load/output load current output	700 Ω (at $U_B = 24 \text{ V}$, $R_B = [U_B - 10 \text{ V}] / 20 \text{ mA}$)

Connection data

Connection method	Screw connection
Stripping length	8 mm

RAD-ISM-900-BD-BUS - Wireless module



2867092

<https://www.phoenixcontact.com/us/products/2867092>

Conductor cross-section flexible	0.2 mm ² ... 2.5 mm ²
Conductor cross-section rigid	0.2 mm ² ... 4 mm ²
Cross section AWG	24 ... 14
Screw thread	M3

Interfaces

Wireless

Direction	Bi-directional
Frequency	900 MHz
Frequency range	902 MHz ... 928 MHz
Number of channel groups	4
Number of channels per group	63
Transmission power	1 W

Wireless

Frequency band	900 MHz
----------------	---------

Dimensions

Width	22.5 mm
Height	99 mm
Depth	114.5 mm

Material specifications

Color	green
Housing material	Polyamide PA non-reinforced

Environmental and real-life conditions

Ambient conditions

Degree of protection	IP20
Ambient temperature (operation)	-40 °C ... 70 °C -40 °F ... 158 °F
Ambient temperature (storage/transport)	-40 °C ... 85 °C

Approvals

Conformity/Approvals

Conformance	FCC Directive, Part 15.247 ISC Directive RSS 210
UL, USA / Canada	Class I, Div. 2, Groups A, B, C, D

EMC data

Electromagnetic compatibility	FCC Part 15.247 / ISC RSS 210
-------------------------------	-------------------------------

Mounting

Assembly note	on standard DIN rail NS 35 in accordance with EN 60715
---------------	--

RAD-ISM-900-BD-BUS - Wireless module



2867092

<https://www.phoenixcontact.com/us/products/2867092>

Mounting position	any
-------------------	-----

Drawings

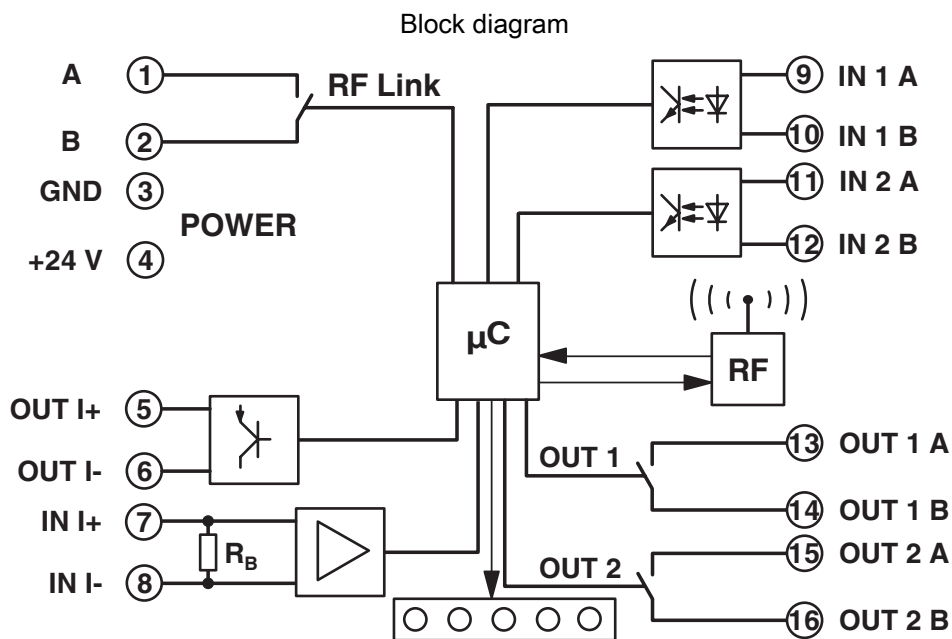

RAD-ISM-900-BD-BUS - Wireless module



2867092

<https://www.phoenixcontact.com/us/products/2867092>

Environmental product compliance

EU REACH SVHC

REACH candidate substance (CAS No.)	No substance above 0.1 wt%
-------------------------------------	----------------------------

Phoenix Contact 2026 © - all rights reserved

<https://www.phoenixcontact.com>

Phoenix Contact USA
586 Fulling Mill Road
Middletown, PA 17057, United States
(+717) 944-1300
info@phoenixcon.com