

IB IL 24 DI 32/HD-PAC - Digital module



2862835

<https://www.phoenixcontact.com/us/products/2862835>

Please be informed that the data shown in this PDF document is generated from our online catalog. Please find the complete data in the user documentation. Our general terms of use for downloads are valid.



Inline, Digital input terminal, Digital inputs: 32, 24 V DC, connection technology: 1-conductor, transmission speed in the local bus: 500 kbps, degree of protection: IP20, including Inline connectors and marking fields

Product description

The terminal is designed for use within an Inline station. It is used to acquire digital signals.

Your advantages

- 32 digital inputs
- Connection of sensors in 1-conductor technology

Commercial data

Item number	2862835
Packing unit	1 pc
Minimum order quantity	1 pc
Sales key	DR01
Product key	DRI131
GTIN	4017918907594
Weight per piece (including packing)	201.1 g
Weight per piece (excluding packing)	185 g
Customs tariff number	85389099
Country of origin	DE

Technical data

Dimensions

Dimensional drawing	
Width	48.8 mm
Height	119.8 mm
Depth	71.5 mm
Note on dimensions	Housing dimensions

Notes

Note on application

Note on application	Only for industrial use
---------------------	-------------------------

Utilization restriction

CCCex note	Use in potentially explosive areas is not permitted in China.
------------	---

Material specifications

Color (Housing)	green (RAL 6021)
-----------------	------------------

Interfaces

Inline local bus

Number of interfaces	2
Connection method	Inline data jumper
Transmission speed	500 kbps

System properties

Programming data (LocalbusSlave)

Length code (hex)	02
ID code (dec.)	190
Length code (dec)	02
Process data channel	32 bit
Input address area	4 Byte
Output address area	0 Byte
Parameter channel (PCP)	0 Byte
Register length (bus)	32 bit

Fieldbus data telegram (PROFIBUS)

Required parameter data	1 Byte
Required configuration data	4 Byte

Input data

Digital:

Input name	Digital inputs
Description of the input	IEC 61131-2 type 1
Number of inputs	32
Connection method	Spring-cage connection
Connection technology	1-conductor
Input voltage	24 V DC
Input voltage range "0" signal	-3 V DC ... 5 V DC
Input voltage range "1" signal	15 V DC ... 30 V DC
Nominal input voltage U_{IN}	24 V DC
Nominal input current at U_{IN}	typ. 2.8 mA
Typical input current per channel	2.8 mA
Typical response time	2 ms
Delay at signal change from 0 to 1	2 ms
Delay at signal change from 1 to 0	4 ms
Protective circuit	Short-circuit and overload protection

Product properties

Product type	I/O component
Product family	Inline
Type	modular
Scope of supply	including Inline connectors and marking fields
No. of channels	32
Operating mode	Process data operation with 2 words

Insulation characteristics

Overvoltage category	II (IEC 60664-1, EN 60664-1)
Pollution degree	2 (IEC 60664-1, EN 60664-1)

Electrical properties

Maximum power dissipation for nominal condition	3.6 W
---	-------

Potentials: Communications power (U_L)

Supply voltage	7.5 V DC (via voltage jumper)
Current draw	max. 90 mA (HW 00)
	max. 30 mA (from HW 01)

Potentials: Segment circuit supply (U_S)

Supply voltage	24 V DC (via voltage jumper)
Supply voltage range	19.2 V DC ... 30 V DC (including all tolerances, including ripple)
Current draw	max. 50 mA

Electrical isolation/isolation of the voltage ranges

Test voltage: 7.5 V supply (bus logics)/24 V supply (I/O)	500 V AC, 50 Hz, 1 min
Test voltage: 7.5 V supply (bus logic)/functional ground	500 V AC, 50 Hz, 1 min
Test voltage: 24 V supply (I/O) / functional ground	500 V AC, 50 Hz, 1 min

Connection data

Connection technology

Connection name	Inline connector
-----------------	------------------

Inline connector

Connection method	Spring-cage connection
Conductor cross-section, rigid	0.08 mm ² ... 1.5 mm ²
Conductor cross-section, flexible	0.08 mm ² ... 1.5 mm ²
Conductor cross-section AWG	28 ... 16
Stripping length	8 mm

Environmental and real-life conditions

Ambient conditions

Ambient temperature (operation)	-25 °C ... 55 °C
Degree of protection	IP20
Air pressure (operation)	70 kPa ... 106 kPa (up to 3000 m above sea level)
Air pressure (storage/transport)	70 kPa ... 106 kPa (up to 3000 m above sea level)
Ambient temperature (storage/transport)	-25 °C ... 85 °C
Permissible humidity (operation)	10 % ... 95 % (non-condensing)
Permissible humidity (storage/transport)	10 % ... 95 % (non-condensing)

Mechanical test

Vibration resistance in accordance with EN 60068-2-6/IEC 60068-2-6	5g
Shock in accordance with EN 60068-2-27/IEC 60068-2-27	25g

Standards and regulations

Protection class	III (IEC 61140, EN 61140, VDE 0140-1)
------------------	---------------------------------------

Mounting

Mounting type	DIN rail mounting
---------------	-------------------

IB IL 24 DI 32/HD-PAC - Digital module

2862835

<https://www.phoenixcontact.com/us/products/2862835>

Drawings

Dimensional drawing



Dimensions (in mm)

Connection diagram

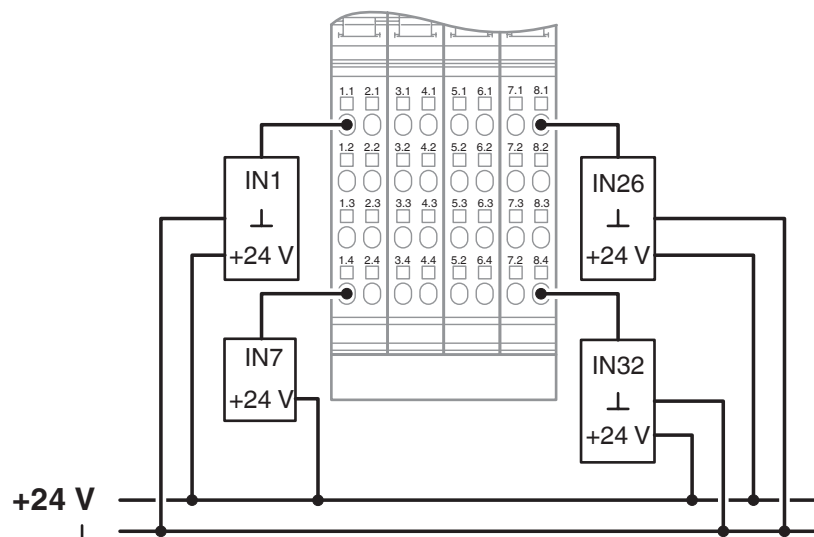

Connection example

IB IL 24 DI 32/HD-PAC - Digital module

2862835

<https://www.phoenixcontact.com/us/products/2862835>

Block diagram

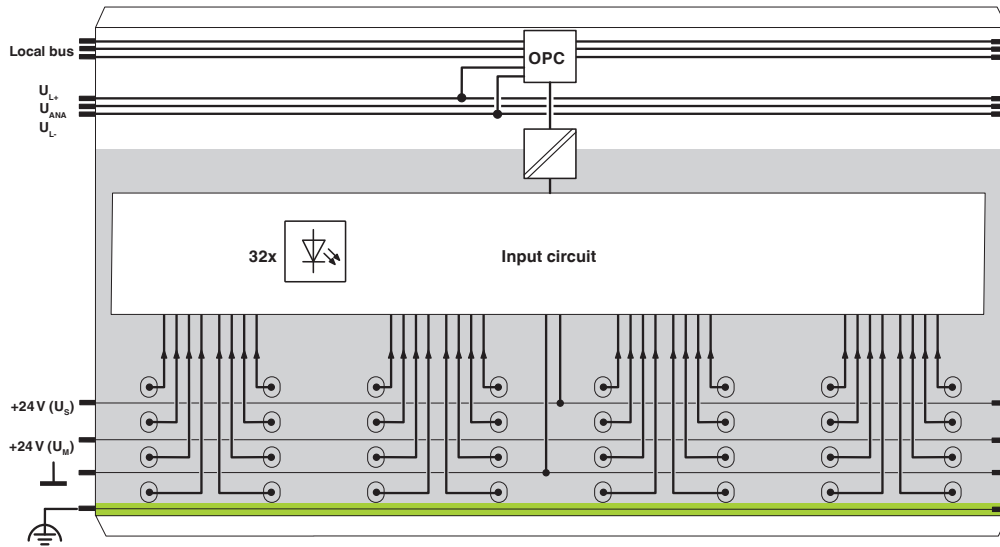

Internal wiring of the terminal points

2862835

<https://www.phoenixcontact.com/us/products/2862835>

Approvals

To download certificates, visit the product detail page: <https://www.phoenixcontact.com/us/products/2862835>



DNV GL

Approval ID: TAA00000BN



BV

Approval ID: 21595/C1 BV

ABS

Approval ID: 22-2226444-PDA



cULus Recognized

Approval ID: E140324



cULus Listed

Approval ID: E199827

2862835

<https://www.phoenixcontact.com/us/products/2862835>

Classifications

ECLASS

ECLASS-13.0	27242604
ECLASS-15.0	27242604

ETIM

ETIM 10.0	EC001599
-----------	----------

UNSPSC

UNSPSC 21.0	32151600
-------------	----------

2862835

<https://www.phoenixcontact.com/us/products/2862835>

Environmental product compliance

EU RoHS

Fulfills EU RoHS substance requirements	Yes
Exemption	7(a), 7(c)-I

China RoHS

Environment friendly use period (EFUP)	EFUP-50
	An article-related China RoHS declaration table can be found in the download area for the respective article under "Manufacturer declaration". For all articles with EFUP-E, no China RoHS declaration table issued and required.

EU REACH SVHC

REACH candidate substance (CAS No.)	Lead(CAS: 7439-92-1)
SCIP	d49d371d-d582-410c-81b4-a6c1da11d6d5

EF3.1 Climate Change

CO2e kg	4.536 kg CO2e
---------	---------------

Phoenix Contact 2026 © - all rights reserved
<https://www.phoenixcontact.com>

Phoenix Contact USA
586 Fulling Mill Road
Middletown, PA 17057, United States
(+717) 944-1300
info@phoenixcon.com