

# ST-REL3-KG 24/21 - Relay connectors



2861014

<https://www.phoenixcontact.com/us/products/2861014>

Please be informed that the data shown in this PDF document is generated from our online catalog. Please find the complete data in the user documentation. Our general terms of use for downloads are valid.



Relay connector, equipped with miniature switching relay, contacts (AgNi): medium to large loads, 1 changeover contact, input voltage 24 V AC/DC, with LED display, pluggable into basic terminal blocks

## Commercial data

Item number	2861014
Packing unit	10 pc
Minimum order quantity	1 pc
Sales key	C460
Product key	DK61B2
GTIN	4017918078676
Weight per piece (including packing)	40.53 g
Weight per piece (excluding packing)	39.6 g
Customs tariff number	85364190
Country of origin	DE

# ST-REL3-KG 24/21 - Relay connectors



2861014

<https://www.phoenixcontact.com/us/products/2861014>

## Technical data

### Product properties

Product type	Relay Module
Operating mode	100% operating factor
Mechanical service life	approx. $2 \times 10^7$ cycles

### Data management status

Date of last data management	01.04.2026
------------------------------	------------

### Electrical properties

Maximum power dissipation for nominal condition	0.5 W
Test voltage (Winding/contact)	2.5 kV AC (50 Hz, 1 min., winding/contact)

### Input data

#### Coil side

Nominal input voltage $U_N$	24 V AC/DC
Input voltage range	19.2 V AC/DC ... 26.4 V AC/DC (20 °C)
Drive and function	monostable
Drive (polarity)	polarized
Typical input current at $U_N$	21 mA
Typical response time	7 ms
Typical release time	11 ms (with DC)
Protective circuit	Bridge rectifier, varistor
Operating voltage display	yes

### Output data

#### Switching

Contact switching type	1 changeover contact
Type of switch contact	Single contact
Contact material	AgNi
Maximum switching voltage	250 V AC/DC
Limiting continuous current	6 A
Maximum inrush current	8 A
Interrupting rating (ohmic load) max.	95 W (at 24 V DC) 50 W (at 48 V DC) 45 W (at 60 V DC) 35 W (at 110 V DC) 55 W (at 220 V DC) 1500 VA (for 250 V AC)

### Dimensions

#### Item dimensions

# ST-REL3-KG 24/21 - Relay connectors



2861014

<https://www.phoenixcontact.com/us/products/2861014>

Width	20.8 mm
Height	33 mm
Depth	66.5 mm

## Material specifications

Color	green (RAL 6021)
-------	------------------

## Environmental and real-life conditions

### Ambient conditions

Ambient temperature (operation)	-20 °C ... 50 °C
Ambient temperature (storage/transport)	-20 °C ... 70 °C

## Standards and regulations

Standards/regulations	DIN VDE 0110b, Gr. C for 250 V DC
	IEC 60255/DIN VDE 0435 (in relevant parts)
	DIN EN 50178/VDE 0160 (in relevant parts)
	EN 60730/DIN VDE 0631
	DIN VDE 0160 (in relevant parts)

## Mounting

Mounting type	Plug-in mounting
---------------	------------------

2861014

<https://www.phoenixcontact.com/us/products/2861014>

## Drawings

Circuit diagram

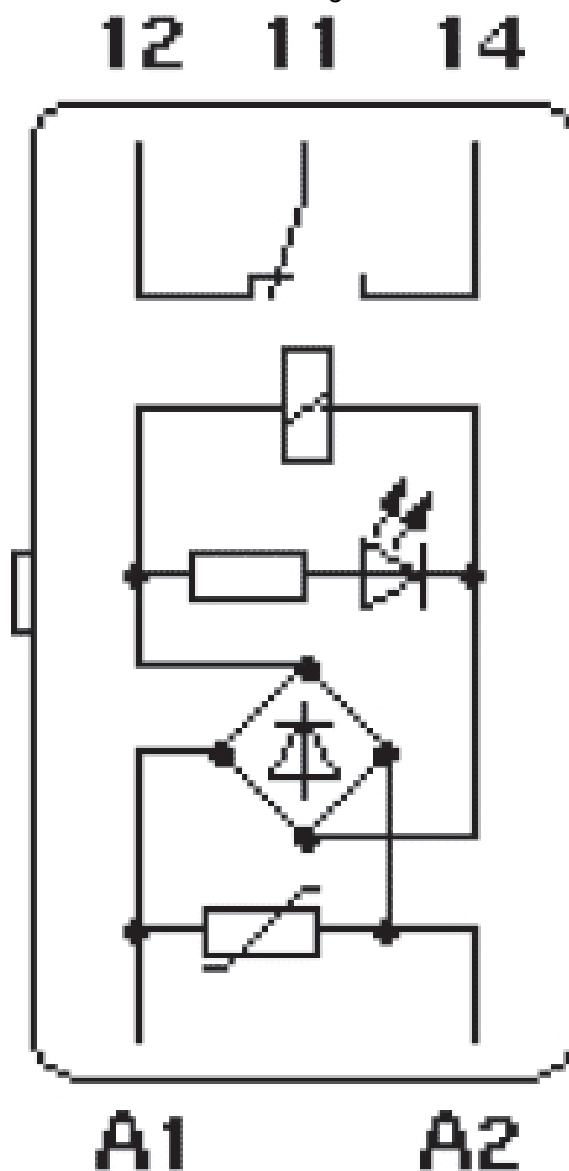

# ST-REL3-KG 24/21 - Relay connectors



2861014

<https://www.phoenixcontact.com/us/products/2861014>

## Approvals

To download certificates, visit the product detail page: <https://www.phoenixcontact.com/us/products/2861014>



**EAC**

Approval ID: RU\*C-DE.\*08.B.00010

# ST-REL3-KG 24/21 - Relay connectors



2861014

<https://www.phoenixcontact.com/us/products/2861014>

## Classifications

### ECLASS

ECLASS-13.0	27371601
ECLASS-15.0	27371601

### ETIM

ETIM 10.0	EC001437
-----------	----------

### UNSPSC

UNSPSC 21.0	39122300
-------------	----------

# ST-REL3-KG 24/21 - Relay connectors



2861014

<https://www.phoenixcontact.com/us/products/2861014>

## Environmental product compliance

### EU RoHS

Fulfills EU RoHS substance requirements	Yes
Exemption	7(a), 7(c)-I

### China RoHS

Environment friendly use period (EFUP)	EFUP-50
	An article-related China RoHS declaration table can be found in the download area for the respective article under "Manufacturer declaration". For all articles with EFUP-E, no China RoHS declaration table issued and required.

### EU REACH SVHC

REACH candidate substance (CAS No.)	Lead(CAS: 7439-92-1)
SCIP	188af823-79b8-4d5c-a8e2-0d90e4e10daf

### EF3.1 Climate Change

CO2e kg	0.864 kg CO2e
---------	---------------

Phoenix Contact 2026 © - all rights reserved  
<https://www.phoenixcontact.com>

Phoenix Contact USA  
586 Fulling Mill Road  
Middletown, PA 17057, United States  
(+717) 944-1300  
[info@phoenixcon.com](mailto:info@phoenixcon.com)