

PT 2X2-HF-12 DC-ST - Surge protection plug



2839570

<https://www.phoenixcontact.com/us/products/2839570>

Please be informed that the data shown in this PDF document is generated from our online catalog. Please find the complete data in the user documentation. Our general terms of use for downloads are valid.



Surge protection plug for the base element, normal mode voltage coarse and fine protection for two floating double wires in IT. Design: 12 V DC

Your advantages

- Easy testing and documentation with CHECKMASTER 2 with pluggable protective modules
- Maximum ease of maintenance, thanks to the 2-piece design
- Easy selection for all possible demands in MCR applications with a complete product portfolio
- The signal is not influenced during maintenance work, thanks to the impedance-neutral insertion and removal of protective plugs

Commercial data

Item number	2839570
Packing unit	10 pc
Minimum order quantity	1 pc
Sales key	CL03
Product key	CL3121
GTIN	4017918591113
Weight per piece (including packing)	25.87 g
Weight per piece (excluding packing)	22.149 g
Customs tariff number	85363010
Country of origin	DE

PT 2X2-HF-12 DC-ST - Surge protection plug

2839570

<https://www.phoenixcontact.com/us/products/2839570>

Technical data

Product properties

Product type	Surge protection for information technology
Product family	PLUGTRAB PT
IEC test classification	C1
	C2
	C3
	D1
VDE requirement class	C1
	C2
	C3
	D1
Type	Male
Number of positions	5
Arrester can be tested with CHECKMASTER from software version:	From SW rev. 1.00
Wire pairs per module	2

Insulation characteristics

Overvoltage category	III
Pollution degree	2

Electrical properties

Nominal voltage U_N	12 V DC
-----------------------	---------

Connection data

Connection method	Screw connection (in connection with the base element)
Conductor cross-section flexible	0.2 mm ² ... 2.5 mm ²
Conductor cross-section rigid	0.2 mm ² ... 4 mm ²
Conductor cross-section AWG	24 ... 12

Dimensions

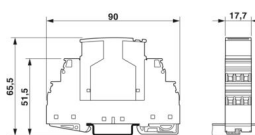
Dimensional drawing	
Width	17.7 mm
Height	45 mm
Depth	52 mm
Horizontal pitch	1 Div.

Material specifications

PT 2X2-HF-12 DC-ST - Surge protection plug



2839570

<https://www.phoenixcontact.com/us/products/2839570>

Color	black (RAL 9005)
Flammability rating according to UL 94	V-0
Housing material	PA

Mechanical properties

Mechanical data

Open side panel	No
-----------------	----

Protective circuit

Direction of action	Line-Line & Line-Signal Ground/Shield & optional Signal Ground/Shield-Earth Ground
Nominal voltage U_N	12 V DC
Maximum continuous operating voltage U_C	13 V DC 9 V AC
Rated current	450 mA (45 °C)
Operating effective current I_C at U_C	$\leq 5 \mu\text{A}$
Protective conductor current I_{PE}	$\leq 4 \mu\text{A}$ (with PT 2X2-BE) $\leq 1 \mu\text{A}$ (with PT 2X2+F-BE)
Nominal discharge current I_n (8/20) μs (line-line)	10 kA
Nominal discharge current I_n (8/20) μs (line-ground)	10 kA
Pulse discharge current I_{imp} (10/350) μs	2.5 kA
Total discharge current I_{Total} (8/20) μs	20 kA
Max. discharge current I_{max} (8/20) μs maximum (line-line)	10 kA
Max. discharge current I_{max} (8/20) μs maximum (line-earth)	10 kA
Nominal pulse current I_{an} (10/1000) μs (line-line)	67 A
Output voltage limitation at 1 kV/ μs (line-line) spike	$\leq 50 \text{ V}$
Output voltage limitation at 1 kV/ μs (line-earth) spike	$\leq 450 \text{ V}$ $\leq 1 \text{ kV}$ (with PT 2X2+F-BE)
Output voltage limitation at 1 kV/ μs (line-line) static	$\leq 25 \text{ V}$
Output voltage limitation at 1 kV/ μs (line-signal ground) static	$\leq 450 \text{ V}$
Residual voltage at I_n (conductor-conductor)	$\leq 25 \text{ V}$
Residual voltage with I_{an} (10/1000) μs (line-line)	$\leq 23 \text{ V}$
Voltage protection level U_p (line-line)	$\leq 100 \text{ V}$ (C2 - 10 kV / 5 kA)
Voltage protection level U_p (line-earth)	$\leq 450 \text{ V}$ (C2 - 10 kV / 5 kA)
Response time t_A (line-line)	$\leq 500 \text{ ns}$
Response time t_A (line-earth)	$\leq 500 \text{ ns}$
Input attenuation aE, sym.	0.2 dB ($\leq 5 \text{ MHz}$)
Cut-off frequency f_g (3 dB), sym. in 100 Ω system	typ. 70 MHz
Capacity (Core-Core)	typ. 30 pF
Resistance per path	2.2 Ω
Surge protection fault message	none
Max. required back-up fuse	500 mA (T)
Impulse durability (line-line)	C2 - 10 kV / 5 kA
Impulse durability (line-earth)	C2 - 10 kV / 5 kA

PT 2X2-HF-12 DC-ST - Surge protection plug



2839570

<https://www.phoenixcontact.com/us/products/2839570>

	D1 - 2.5 kA
--	-------------

Environmental and real-life conditions

Ambient conditions

Degree of protection	IP20
Ambient temperature (operation)	-40 °C ... 85 °C

Standards and regulations

VDE requirement class	C1
	C2
	C3
	D1

Standards Information technology specification

Standards/regulations	IEC 61643-21
	IEC 61643-21

Air clearances and creepage distances

Standards/regulations	DIN VDE 0110-1 / IEC 60664-1
Standards/specifications	IEC 61643-21
Note	2000

Mounting

Mounting type	on base element
---------------	-----------------

PT 2X2-HF-12 DC-ST - Surge protection plug

2839570

<https://www.phoenixcontact.com/us/products/2839570>



Drawings

Dimensional drawing

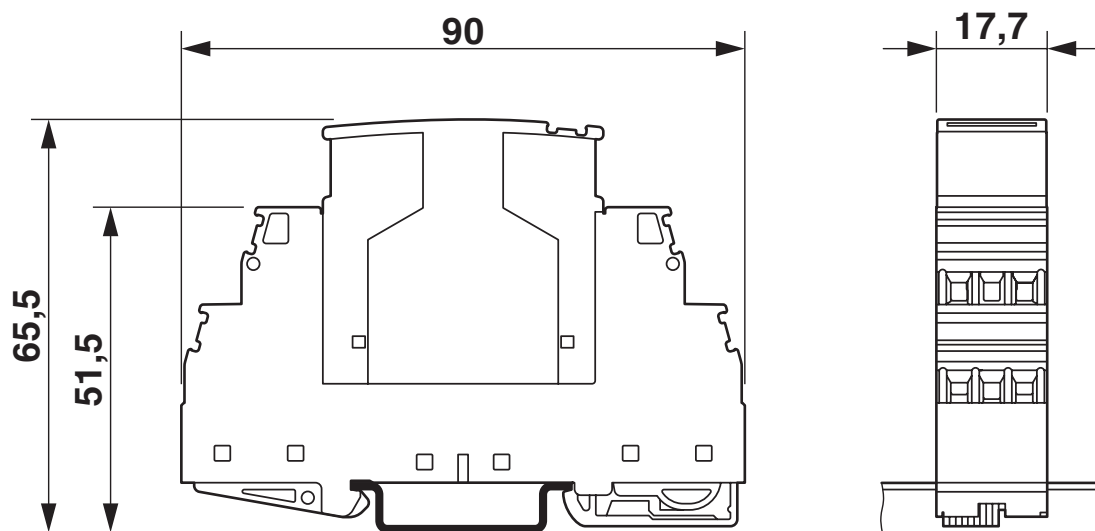

The figure shows the complete module consisting of a base element and connector

PT 2X2-HF-12 DC-ST - Surge protection plug



2839570

<https://www.phoenixcontact.com/us/products/2839570>

Diagram



PT 2X2-HF-12 DC-ST - Surge protection plug



2839570

<https://www.phoenixcontact.com/us/products/2839570>

Circuit diagram

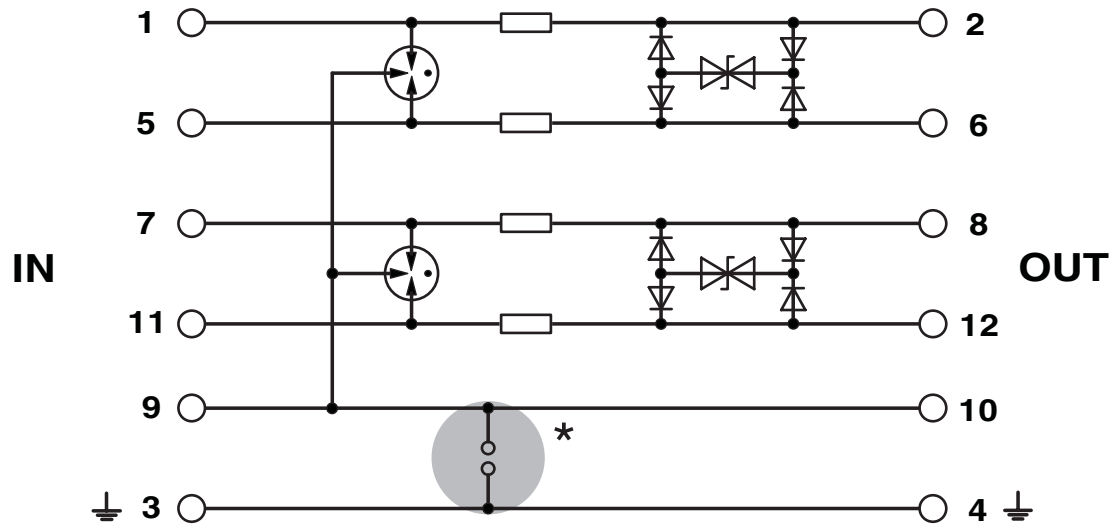

PT 2X2-HF-12 DC-ST - Surge protection plug



2839570

<https://www.phoenixcontact.com/us/products/2839570>

Approvals

To download certificates, visit the product detail page: <https://www.phoenixcontact.com/us/products/2839570>



DNV GL

Approval ID: TAE00001N6



UL Listed

Approval ID: FILE E 138168

	Nominal voltage U_N	Nominal current I_N	Cross section AWG	Cross section mm^2
keine				
	24 V	0.45 A	-	-



cUL Listed

Approval ID: FILE E 333250



UL Listed

Approval ID: FILE E 333250

PT 2X2-HF-12 DC-ST - Surge protection plug



2839570

<https://www.phoenixcontact.com/us/products/2839570>

Classifications

ECLASS

ECLASS-13.0	27171503
ECLASS-15.0	27171503

ETIM

ETIM 10.0	EC001466
-----------	----------

UNSPSC

UNSPSC 21.0	39121600
-------------	----------

PT 2X2-HF-12 DC-ST - Surge protection plug



2839570

<https://www.phoenixcontact.com/us/products/2839570>

Environmental product compliance

EU RoHS

Fulfills EU RoHS substance requirements	Yes
Exemption	7(a), 7(c)-I

China RoHS

Environment friendly use period (EFUP)	EFUP-50
	An article-related China RoHS declaration table can be found in the download area for the respective article under "Manufacturer declaration". For all articles with EFUP-E, no China RoHS declaration table issued and required.

EU REACH SVHC

REACH candidate substance (CAS No.)	Lead(CAS: 7439-92-1)
SCIP	4bfc8851-b716-42ce-bd16-816e5b206168

EF3.1 Climate Change

CO2e kg	0.769 kg CO2e
---------	---------------

Phoenix Contact 2026 © - all rights reserved
<https://www.phoenixcontact.com>

Phoenix Contact USA
586 Fulling Mill Road
Middletown, PA 17057, United States
(+717) 944-1300
info@phoenixcon.com