

# PT 4-12DC-ST - Surge protection plug



2839237

<https://www.phoenixcontact.com/us/products/2839237>

Please be informed that the data shown in this PDF document is generated from our online catalog. Please find the complete data in the user documentation. Our general terms of use for downloads are valid.



Protective plug PT with protective circuit for a 4-core floating signal circuit. Nominal voltage: 12 V DC

## Your advantages

- Easy testing and documentation with CHECKMASTER 2 with pluggable protective modules
- Maximum ease of maintenance, thanks to the 2-piece design
- Easy selection for all possible demands in MCR applications with a complete product portfolio
- The signal is not influenced during maintenance work, thanks to the impedance-neutral insertion and removal of protective plugs

## Commercial data

Item number	2839237
Packing unit	10 pc
Minimum order quantity	1 pc
Sales key	CL21
Product key	CL2111
GTIN	4017918182779
Weight per piece (including packing)	26.2 g
Weight per piece (excluding packing)	21.143 g
Customs tariff number	85363010
Country of origin	DE

# PT 4-12DC-ST - Surge protection plug

2839237

<https://www.phoenixcontact.com/us/products/2839237>

## Technical data

### Product properties

Product type	Surge protection for MCR technology
Product family	PLUGTRAB PT
IEC test classification	C1
	C2
	C3
	D1
VDE requirement class	C1
	C2
	C3
	D1
Type	Male
Surge protection fault message	none
Arrester can be tested with CHECKMASTER from software version:	From SW rev. 1.00

### Insulation characteristics

Overvoltage category	III
Pollution degree	2

### Electrical properties

Nominal voltage $U_N$	12 V DC
-----------------------	---------

### Connection data

Connection method	Screw connection (in connection with the base element)
Screw thread	M3
Tightening torque	0.5 Nm
Conductor cross-section flexible	0.2 mm <sup>2</sup> ... 2.5 mm <sup>2</sup>
Conductor cross-section rigid	0.2 mm <sup>2</sup> ... 4 mm <sup>2</sup>
Conductor cross-section AWG	24 ... 12

### Dimensions

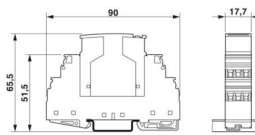
Dimensional drawing	
Width	17.7 mm
Height	45 mm
Depth	52 mm
Horizontal pitch	1 Div.
Complete module width	17.7 mm

# PT 4-12DC-ST - Surge protection plug



2839237

<https://www.phoenixcontact.com/us/products/2839237>

Complete module height	90 mm
Complete module depth	65.5 mm

## Material specifications

Color	black (RAL 9005)
	copper color
Flammability rating according to UL 94	V-0
Housing material	PA 6.6

## Mechanical properties

### Mechanical data

Open side panel	No
-----------------	----

## Protective circuit

Direction of action	Line-Line & Line-Signal Ground/Shield & optional Signal Ground/Shield-Earth Ground
Nominal voltage $U_N$	12 V DC
Maximum continuous operating voltage $U_C$	12.8 V DC
	9 V AC
Rated current	2 A (80 °C)
Operating effective current $I_C$ at $U_C$	$\leq 1$ mA
Protective conductor current $I_{PE}$	$\leq 4$ $\mu$ A (Directly grounded)
	$\leq 1$ $\mu$ A (with PT 4+F-BE)
Nominal discharge current $I_n$ (8/20) $\mu$ s (line-line)	690 A
Nominal discharge current $I_n$ (8/20) $\mu$ s (line-ground)	10 kA
Pulse discharge current $I_{imp}$ (10/350) $\mu$ s	2.5 kA (per path)
Total discharge current $I_{Total}$ (8/20) $\mu$ s	20 kA
Max. discharge current $I_{max}$ (8/20) $\mu$ s maximum (line-line)	690 A
Max. discharge current $I_{max}$ (8/20) $\mu$ s maximum (line-earth)	10 kA
Nominal pulse current $I_{an}$ (10/1000) $\mu$ s (line-line)	128 A
Output voltage limitation at 1 kV/ $\mu$ s (line-line) spike	$\leq 20$ V
	$\leq 450$ V $\leq 1$ kV (with PT 4+F-BE)
Output voltage limitation at 1 kV/ $\mu$ s (line-line) static	$\leq 18$ V
Residual voltage at $I_n$ (conductor-conductor)	$\leq 50$ V
Residual voltage with $I_{an}$ (10/1000) $\mu$ s (line-line)	$\leq 25$ V
Voltage protection level $U_p$ (line-line)	$\leq 40$ V (C1 - 1 kV / 500 A)
Voltage protection level $U_p$ (line-earth)	$\leq 450$ V
	$\leq 1$ kV (with PT 4+F-BE)
Response time $t_A$ (line-line)	$\leq 1$ ns
Response time $t_A$ (line-earth)	$\leq 100$ ns
Response time $t_A$ (line-signal ground)	$\leq 1$ ns
Input attenuation aE, sym.	0.1 dB ( $\leq 600$ kHz)
Cut-off frequency $f_g$ (3 dB), sym. in 50 $\Omega$ system	typ. 3 MHz

# PT 4-12DC-ST - Surge protection plug



2839237

<https://www.phoenixcontact.com/us/products/2839237>

Surge protection fault message	none
Max. required back-up fuse	2 A (T)
Impulse durability (line-line)	C1 - 1 kV / 500 A
	C3 - 100 A
Impulse durability (line-earth)	C2 - 10 kV / 5 kA
	D1 - 2.5 kA

## Environmental and real-life conditions

### Ambient conditions

Degree of protection	IP20
Ambient temperature (operation)	-40 °C ... 85 °C

## Standards and regulations

VDE requirement class	C1
	C2
	C3
	D1

### Standards Information technology specification

Standards/regulations	IEC 61643-21
	DIN EN 61643-21
	UL 497B
	IEC 61643-21
	DIN EN 61643-21
UL 497B	

### Air clearances and creepage distances

Standards/regulations	VDE 0110-1 / IEC 60664-1
Standards/specifications	IEC 61643-21
Note	2000

## Mounting

Mounting type	on base element
---------------	-----------------

# PT 4-12DC-ST - Surge protection plug

2839237

<https://www.phoenixcontact.com/us/products/2839237>

## Drawings

Dimensional drawing



The figure shows the complete module consisting of a base element and connector

Circuit diagram

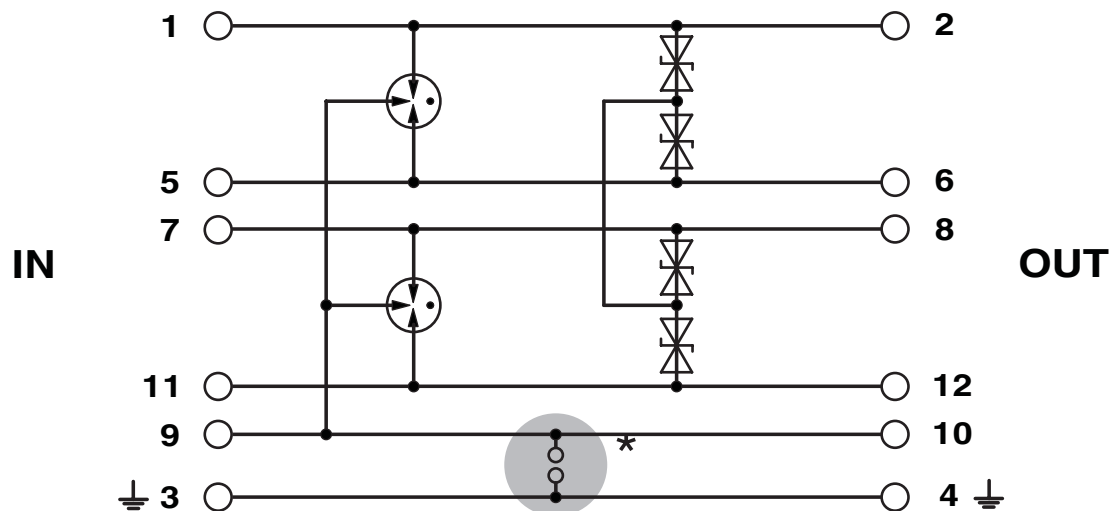

# PT 4-12DC-ST - Surge protection plug





2839237

<https://www.phoenixcontact.com/us/products/2839237>

## Approvals

To download certificates, visit the product detail page: <https://www.phoenixcontact.com/us/products/2839237>

 <b>UL Listed</b> Approval ID: FILE E 138168				
	Nominal voltage $U_N$	Nominal current $I_N$	Cross section AWG	Cross section $\text{mm}^2$
keine				
	12 V	2 A	-	-

 <b>cUL Listed</b> Approval ID: FILE E 333250				
---	--	--	--	--

 <b>UL Listed</b> Approval ID: FILE E 333250				
--	--	--	--	--

# PT 4-12DC-ST - Surge protection plug



2839237

<https://www.phoenixcontact.com/us/products/2839237>

## Classifications

### ECLASS

ECLASS-13.0	27171501
ECLASS-15.0	27171501

### ETIM

ETIM 10.0	EC001466
-----------	----------

### UNSPSC

UNSPSC 21.0	39121600
-------------	----------

# PT 4-12DC-ST - Surge protection plug



2839237

<https://www.phoenixcontact.com/us/products/2839237>

## Environmental product compliance

### EU RoHS

Fulfills EU RoHS substance requirements	Yes
Exemption	7(a), 7(c)-I

### China RoHS

Environment friendly use period (EFUP)	EFUP-50
	An article-related China RoHS declaration table can be found in the download area for the respective article under "Manufacturer declaration". For all articles with EFUP-E, no China RoHS declaration table issued and required.

### EU REACH SVHC

REACH candidate substance (CAS No.)	Lead(CAS: 7439-92-1)
SCIP	f95191be-5310-4789-b29e-60d7ecdb1325

### EF3.1 Climate Change

CO2e kg	1.106 kg CO2e
---------	---------------

Phoenix Contact 2026 © - all rights reserved  
<https://www.phoenixcontact.com>

Phoenix Contact USA  
586 Fulling Mill Road  
Middletown, PA 17057, United States  
(+717) 944-1300  
[info@phoenixcon.com](mailto:info@phoenixcon.com)