

# ST-REL7-HG-B 24/21-21/P - Relay connectors



2826156

<https://www.phoenixcontact.com/us/products/2826156>

Please be informed that the data shown in this PDF document is generated from our online catalog. Please find the complete data in the user documentation. Our general terms of use for downloads are valid.



Relay connector, equipped with remanence miniature switching relay, contacts (AgCdO): medium to large loads, 2 changeover contacts, input voltage 24 V DC, pluggable into basic terminal blocks

## Commercial data

Item number	2826156
Packing unit	1 pc
Note	Made to order (non-returnable)
Sales key	C460
Product key	DK6125
GTIN	4017918077846
Weight per piece (including packing)	62.63 g
Weight per piece (excluding packing)	62.63 g
Customs tariff number	85364190
Country of origin	DE

## Technical data

### Product properties

Product type	Relay Module
Operating mode	100% operating factor
Mechanical service life	approx. $10^7$ cycles

### Data management status

Date of last data management	12.09.2025
------------------------------	------------

### Electrical properties

Maximum power dissipation for nominal condition	2.64 W
Test voltage (Winding/contact)	2.5 kV AC (50 Hz, 1 min., winding/contact)
Test voltage (Changeover contact/changeover contact)	2.5 kV AC (50 Hz, 1 min., changeover contact/changeover contact)

### Input data

#### Coil side

Nominal input voltage $U_N$	24 V DC
Input voltage range	19.2 V DC ... 26.4 V DC
Input voltage range in reference to $U_N$	0.8 ... 1.1
Typical input current at $U_N$	110 mA (response) 35 mA (reset/release)
Pulse time range	0.1 s ... 20 s
Protective circuit	Damping diode, polarity protection; Damping diode, polarity protection diode

### Output data

#### Switching

Contact switching type	Single contact, 2 changeover contacts
Type of switch contact	Single contact
Contact material	AgCdO
Maximum switching voltage	250 V AC 220 V DC
Limiting continuous current	4 A
Maximum inrush current	4 A
Interrupting rating (ohmic load) max.	95 W (at 24 V DC) 95 W (at 48 V DC) 65 W (at 60 V DC) 50 W (at 110 V DC) 60 W (at 220 V DC) 1000 VA (for 250 V AC)

### Dimensions

# ST-REL7-HG-B 24/21-21/P - Relay connectors



2826156

<https://www.phoenixcontact.com/us/products/2826156>

Width	45.6 mm
Height	33 mm
Depth	66.5 mm

## Material specifications

Color	green (RAL 6021)
-------	------------------

## Environmental and real-life conditions

### Ambient conditions

Ambient temperature (operation)	-20 °C ... 50 °C
Ambient temperature (storage/transport)	-20 °C ... 70 °C

## Standards and regulations

Standards/regulations	DIN VDE 0110b, Gr. C for 250 V DC
	DIN VDE 0160 (in relevant parts)

## Mounting

Mounting type	Plug-in mounting
---------------	------------------

Drawings

Circuit diagram

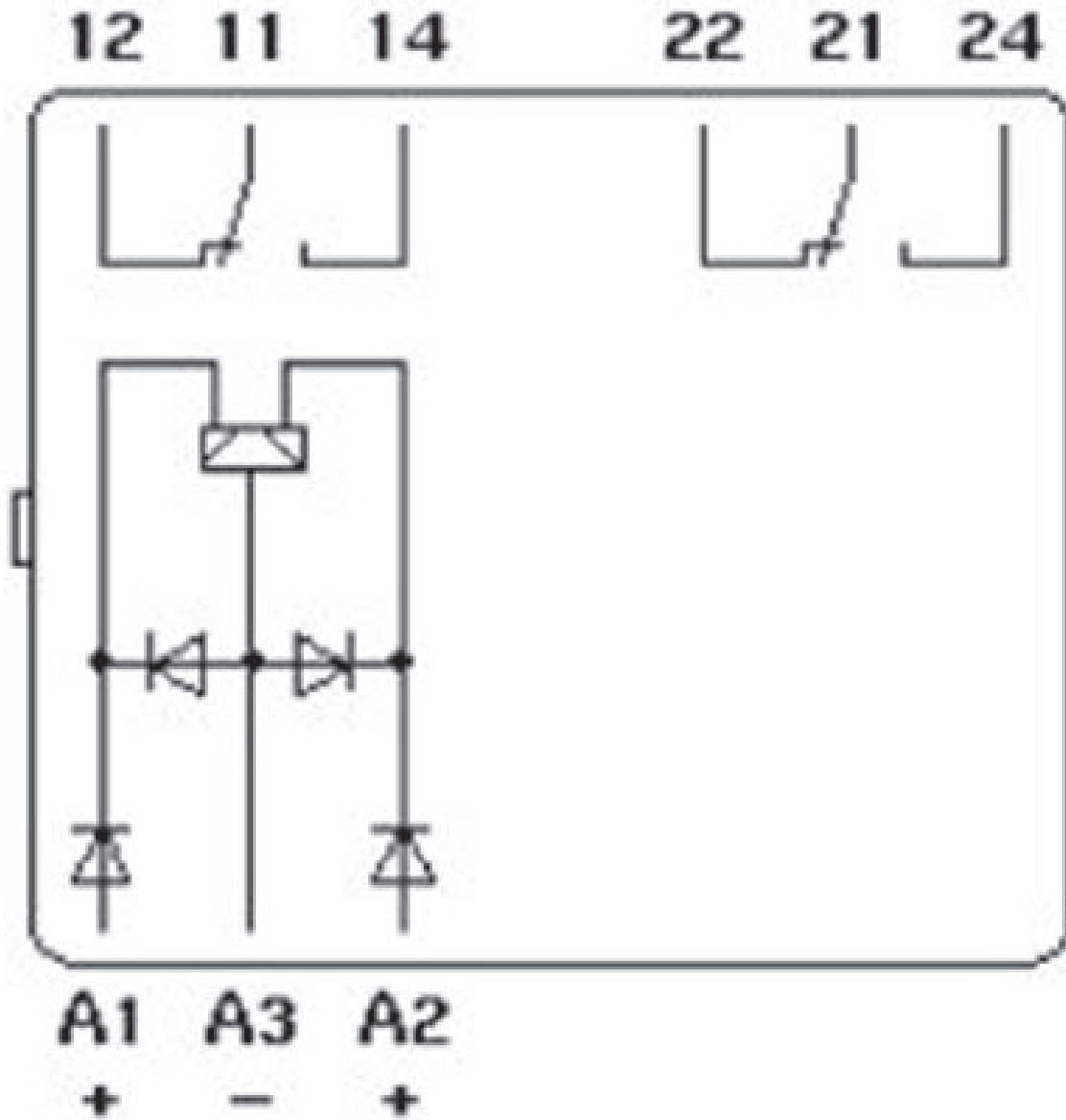

2826156

<https://www.phoenixcontact.com/us/products/2826156>

## Environmental product compliance

### EU RoHS

Fulfills EU RoHS substance requirements	Yes, No exemptions
---	--------------------

### China RoHS

Environment friendly use period (EFUP)	EFUP-50
	An article-related China RoHS declaration table can be found in the download area for the respective article under "Manufacturer declaration". For all articles with EFUP-E, no China RoHS declaration table issued and required.

### EU REACH SVHC

REACH candidate substance (CAS No.)	No substance above 0.1 wt%
-------------------------------------	----------------------------

Phoenix Contact 2026 © - all rights reserved

<https://www.phoenixcontact.com>

Phoenix Contact USA  
586 Fulling Mill Road  
Middletown, PA 17057, United States  
(+717) 944-1300  
[info@phoenixcon.com](mailto:info@phoenixcon.com)