

MCR-T-UI-E-NC - Temperature measuring transducer



2814126

<https://www.phoenixcontact.com/us/products/2814126>

Please be informed that the data shown in this PDF document is generated from our online catalog. Please find the complete data in the user documentation. Our general terms of use for downloads are valid.



MCR-T module, programmable temperature transducer, unconfigured, for thermocouple sensors and resistance temperature detectors, in 2-, 3- or 4-conductor technology, with electrical isolation between input/output and input/auxiliary power

Your advantages

- Freely programmable via MCR/PI-CONF-WIN
- With transistor switching output
- Measure differential temperatures
- Inverse output signal ranges as an option
- For resistance thermometers and thermocouples

Commercial data

Item number	2814126
Packing unit	1 pc
Note	Made to order (non-returnable)
Sales key	C401
Product key	DK1XXX
GTIN	4017918139445
Weight per piece (including packing)	146.7 g
Weight per piece (excluding packing)	124.7 g
Customs tariff number	85437090
Country of origin	DE

Technical data

Notes

Utilization restriction

EMC note	EMC: class A product, see manufacturer's declaration in the download area
----------	---

Product properties

Product type	Temperature transmitter
--------------	-------------------------

Electrical properties

Typical cold point errors	1.5 K
Cold point error, max.	≤ 3 K
Maximum power dissipation for nominal condition	1.51 W
Test voltage input/output	1 kV AC (50 Hz, 60 s)
Test voltage input/power supply	1 kV AC (50 Hz, 60 s)
Maximum temperature coefficient	≤ 0.01 %/K
Temperature coefficient, typical	0.005 %/K
Maximum transmission error	≤ 0.1 % (of maximum range, ±6 mV or ±12 µA at output)

Supply

Supply voltage range	18 V DC ... 30 V DC
Typical current consumption	40 mA
Max. current consumption	≤ 60 mA

Input data

Signal

Input signal	Temperature
--------------	-------------

Measurement

Configurable/programmable	Yes, unconfigured
Sensor types (RTD) that can be used	Pt, Ni, Cu sensors
Sensor types that can be used (TC)	U, T, L, J, E, K, N, S, R, B, C, W, HK
Temperature measuring range	Depending on sensor type used
Temperature measuring range	min. 20 K (RTD, excluding CU10 - 100 K)
	min. 50 K (TC, except type B 100 K)
Temperature measuring range: Pt-Sensoren (DIN / SAMA)	-200 °C ... 850 °C (freely adjustable)
Temperature measuring range: Ni-Sensoren (DIN / SAMA)	-60 °C ... 180 °C (freely adjustable)
Temperature measuring range: Cu-Sensoren (SAMA)	-70 °C ... 500 °C (freely adjustable)
Temperature measuring range: Ni 1000 (Landris & Gyr)	-50 °C ... 160 °C (freely adjustable)
Temperature measuring range: Cu 50	-50 °C ... 200 °C (freely adjustable)
Temperature measuring range: Cu 53	-50 °C ... 180 °C (freely adjustable)
Temperature measuring range: KTY 81-110 (Philips)	-55 °C ... 150 °C (freely adjustable)
Temperature measuring range: Thermoelement Typ U	-200 °C ... 600 °C (freely adjustable)

MCR-T-UI-E-NC - Temperature measuring transducer



2814126

<https://www.phoenixcontact.com/us/products/2814126>

Temperature measuring range: Thermoelement Typ T	-200 °C ... 400 °C (freely adjustable)
Temperature measuring range: Thermoelement Typ L	-200 °C ... 900 °C (freely adjustable)
Temperature measuring range: Thermoelement Typ J	-210 °C ... 1200 °C (freely adjustable)
Temperature measuring range: Thermoelement Typ E	-226 °C ... 1000 °C (freely adjustable)
Temperature measuring range: Thermoelement Typ K	-200 °C ... 1372 °C (freely adjustable)
Temperature measuring range: Thermoelement Typ N	-200 °C ... 1300 °C (freely adjustable)
Temperature measuring range: Thermoelement Typ S	-50 °C ... 1760 °C (freely adjustable)
Temperature measuring range: Thermoelement Typ R	-50 °C ... 1760 °C (freely adjustable)
Temperature measuring range: Thermoelement Typ B	500 °C ... 1820 °C (freely adjustable)
Temperature measuring range: Thermoelement Typ C	-18 °C ... 2316 °C (freely adjustable)
Temperature measuring range: Thermoelement Typ W	-18 °C ... 2316 °C (freely adjustable)
Temperature measuring range: Thermoelement Typ HK	-200 °C ... 800 °C (freely adjustable)
Temperature measuring range: Pt 10	-200 °C ... 850 °C (freely adjustable)
Temperature measuring range: Pt 100	-200 °C ... 850 °C (freely adjustable)
Temperature measuring range: Pt 500	-200 °C ... 850 °C (freely adjustable)
Temperature measuring range: Pt 1000	-200 °C ... 850 °C (freely adjustable)
Temperature measuring range: Ni 10	-60 °C ... 180 °C (freely adjustable)
Temperature measuring range: Ni 100	-60 °C ... 180 °C (freely adjustable)
Temperature measuring range: Ni 500	-60 °C ... 180 °C (freely adjustable)
Temperature measuring range: Ni 1000	-60 °C ... 180 °C (freely adjustable)
Sensor input current	250 µA (Resistance thermometer)
Linear resistance measuring range	0 Ω ... 8000 Ω (freely adjustable, min. measuring range 100 Ω)
Linear mV signal range	-20 mV ... 2400 mV (freely adjustable, minimum measuring range span of 10 mV)
Connection technology	2-, 3-, 4-conductor
Connection method	Pluggable screw connection
Protective circuit	Transient protection
	Surge protection 30 V DC

Output data

Frequency:

Configurable/programmable	no
---------------------------	----

Switching: Transistor

Output description	Can carry a load of 100 mA, switches supply voltage (not protected against short-circuit); locked in case of order-specific configuration, otherwise freely programmable through MCR/PI-CONF-WIN
Continuous load current	100 mA
Output voltage range	18 V DC ... 30 V DC (switches supply voltage, not short-circuit resistant)

Signal: Voltage output / current output

Configurable/programmable	Yes, unconfigured
Voltage output signal	0 V ... 5 V
	0 V ... 10 V

MCR-T-UI-E-NC - Temperature measuring transducer



2814126

<https://www.phoenixcontact.com/us/products/2814126>

	-5 V ... 5 V
	-10 V ... 10 V
	10 V ... 0 V
	5 V ... 0 V
	10 V ... -10 V
	5 V ... -5 V
	1 V ... 5 V
Max. voltage output signal	± 12 V
Current output signal	0 mA ... 20 mA
	4 mA ... 20 mA
	20 mA ... 0 mA
	20 mA ... 4 mA
Max. current output signal	24 mA
Output voltage range with wire break	-12 V ... 12 V
Output voltage range with overrange/underrange	-12 V ... 12 V
Output current range with wire break	0 A ... 24 mA
Output current range with overrange/underrange	0 A ... 24 mA
Load/output load voltage output	≥ 10 kΩ
Load/output load current output	≤ 500 Ω
Ripple	< 20 mV _{PP}
Protective circuit	Transient protection
D/A converter resolution	± 12 bit

Connection data

Connection method	Pluggable screw connection
Stripping length	8 mm
Screw thread	M3
Conductor cross-section rigid	0.2 mm ² ... 2.5 mm ²
Conductor cross-section flexible	0.2 mm ² ... 2.5 mm ²
Conductor cross-section AWG	24 ... 14

Dimensions

Dimensional drawing	
Width	17.5 mm
Height	99 mm
Depth	114.5 mm

Material specifications

MCR-T-UI-E-NC - Temperature measuring transducer



2814126

<https://www.phoenixcontact.com/us/products/2814126>

Color	green (RAL 6021)
Housing material	Polyamide PA non-reinforced

Environmental and real-life conditions

Ambient conditions

Ambient temperature (operation)	-20 °C ... 65 °C
---------------------------------	------------------

Approvals

CE

Certificate	CE-compliant
-------------	--------------

UL, USA/Canada

Identification	Class I, Div. 2, Groups A, B, C, D or Non-Hazardous Locations
----------------	---

GL

Identification	DNV GL
----------------	--------

Mounting

Mounting type	DIN rail mounting
Mounting position	any

MCR-T-UI-E-NC - Temperature measuring transducer

2814126

<https://www.phoenixcontact.com/us/products/2814126>



Drawings

Dimensional drawing

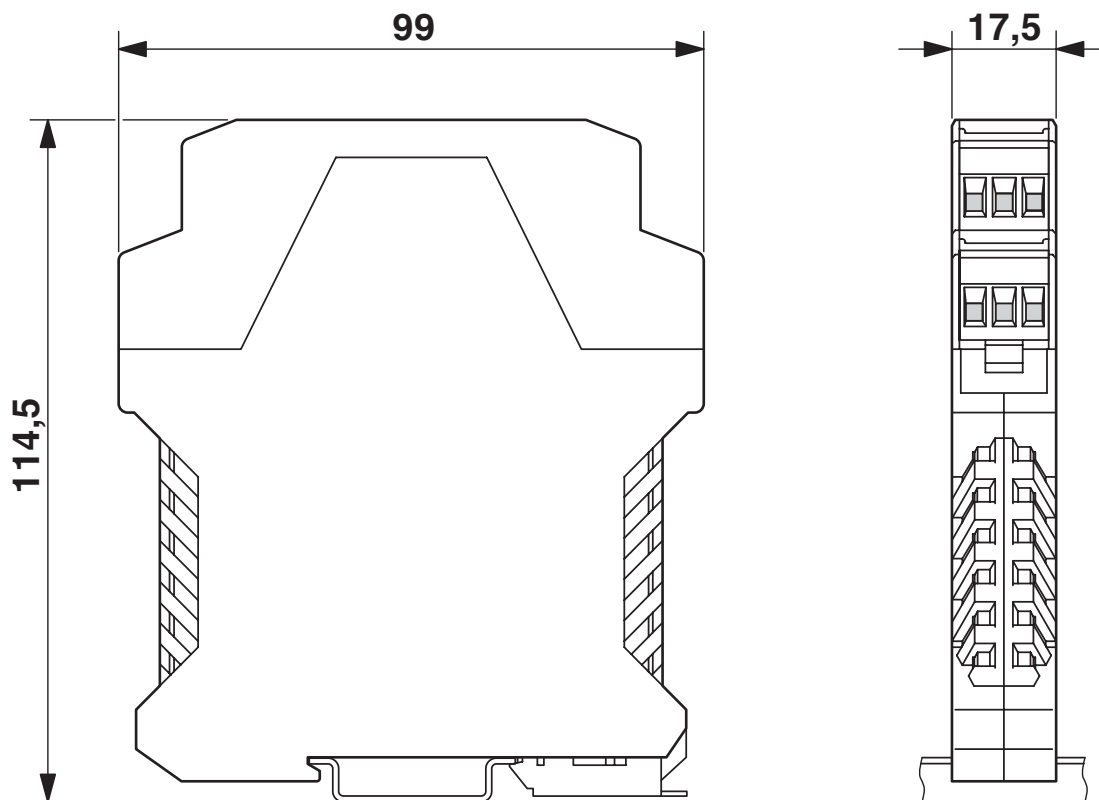

MCR-T-UI-E-NC - Temperature measuring transducer

2814126

<https://www.phoenixcontact.com/us/products/2814126>

Circuit diagram

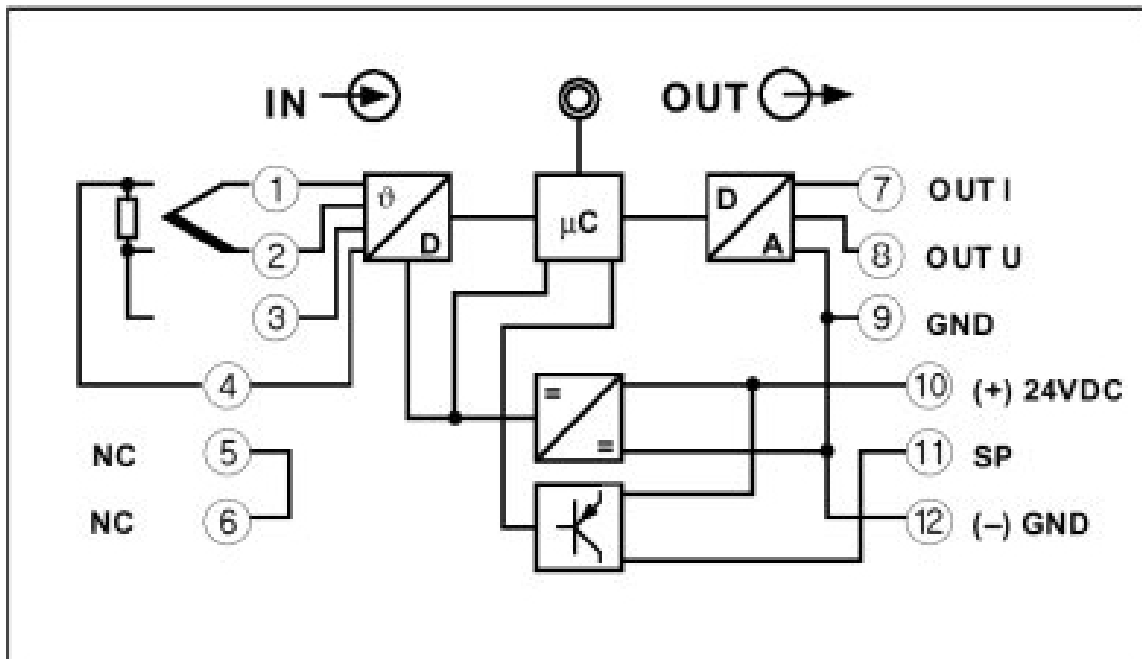

Environmental product compliance

China RoHS

Environment friendly use period (EFUP)	EFUP-50
	An article-related China RoHS declaration table can be found in the download area for the respective article under "Manufacturer declaration". For all articles with EFUP-E, no China RoHS declaration table issued and required.

EU REACH SVHC

REACH candidate substance (CAS No.)	No substance above 0.1 wt%
-------------------------------------	----------------------------

Phoenix Contact 2026 © - all rights reserved
<https://www.phoenixcontact.com>

Phoenix Contact USA
586 Fulling Mill Road
Middletown, PA 17057, United States
(+717) 944-1300
info@phoenixcon.com