

MINI MCR-SL-PT100-LP-SP - Temperature measuring transducer



2810382

<https://www.phoenixcontact.com/us/products/2810382>

Please be informed that the data shown in this PDF document is generated from our online catalog. Please find the complete data in the user documentation. Our general terms of use for downloads are valid.



Loop-powered temperature transducer for Pt 100 temperature sensors, configured via DIP switches, with spring-cage connection, preconfigured (please observe the order key). Replacement part: 2810308 MINI MCR-SL-PT100-LP-NC.

Your advantages

- 2-, 3-, 4-conductor Pt 100 sensors
- Highly-compact loop-powered temperature transducer for electrical isolation, conversion, amplification, and filtering of Pt 100 signals to create standard signals
- Does not require additional auxiliary voltage
- Error indication via diagnostic LED and analog signal
- Input signals can be configured via DIP switches
- 2-way isolation
- Temperature measuring range of -150 °C ... 300 °C
- Supplied by an output loop

Commercial data

Item number	2810382
Packing unit	1 pc
Note	Made to order (non-returnable)
Sales key	C403
Product key	DK1135
GTIN	4046356151993
Weight per piece (including packing)	87.6 g
Weight per piece (excluding packing)	87.6 g
Customs tariff number	85437090
Country of origin	DE

MINI MCR-SL-PT100-LP-SP - Temperature measuring transducer



2810382

<https://www.phoenixcontact.com/us/products/2810382>

Technical data

Product properties

Product type	Temperature transmitter
Product family	MINI Analog

Insulation characteristics

Overvoltage category	II
----------------------	----

Electrical properties

Rated insulation voltage	30 V AC
	50 V DC
Electrical isolation	Basic insulation in accordance with EN 61010
Linearity error	< 0.05 % (for full measuring range)
Test voltage, input/output/supply	1.5 kV AC (50 Hz, 60 s)
Step response (0–99%)	< 200 ms
Maximum temperature coefficient	< 0.02 %/K
Transmission error in the set measuring range	$((90 \text{ K} / \text{set measuring range [K]}) + 0.05)\%$
Transmission error in the full measuring range	$\leq 0.25 \%$

Supply

Designation	Loop-powered
Supply voltage range	12 V DC ... 30 V DC
Max. current consumption	< 4.5 mA (without signal current)
Power consumption	< 150 mW (without signal current)

Input data

Signal

Number of inputs	1
Input signal	Temperature

Measurement

Configurable/programmable	Yes, preconfigured
Sensor types (RTD) that can be used	Pt 100 (IEC 60751/EN 60751)
Temperature measuring range	min. 50 K
Temperature measuring range: PT100	-150 °C ... 300 °C (configurable)
Sensor input current	1 mA (constant)
Max. permissible overall conductor resistance	10 Ω (Per cable)
Connection technology	2-, 3-, 4-conductor
Error detection limit (short-circuit)	< 30 Ω
Error detection limit (underrange)	$30 \Omega \leq (\text{start span} - 2.5\% \text{ span})$
Error detection limit (overrange)	$(\text{end span} + 2.5\% \text{ span}) \leq \text{approx. } 254 \Omega$
Error detection limit (wire break)	$> \text{approx. } 254 \Omega$

MINI MCR-SL-PT100-LP-SP - Temperature measuring transducer

2810382

<https://www.phoenixcontact.com/us/products/2810382>

Output data

Signal

Number of outputs	1
Configurable/programmable	Yes, preconfigured
Current output signal	4 mA ... 20 mA 20 mA ... 4 mA
Max. current output signal	23 mA (output limit)
Load/output load current output	$(U_{\text{supply}} - 12 \text{ V}) / 22 \text{ mA}$
Ripple	< 20 mV _{PP} (at 500 Ω)

Connection data

Connection method	Spring-cage connection
Stripping length	8 mm
Conductor cross-section rigid	0.2 mm ² ... 2.5 mm ²
Conductor cross-section flexible	0.2 mm ² ... 2.5 mm ²
Conductor cross-section AWG	24 ... 12

Dimensions

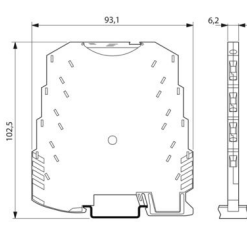
Dimensional drawing	
Width	6.2 mm
Height	93.1 mm
Depth	102.5 mm

Material specifications

Color	green (RAL 6021)
Housing material	PBT
Fire protection for rail vehicles (DIN EN 45545-2) R22	HL 1 - HL 2
Fire protection for rail vehicles (DIN EN 45545-2) R23	HL 1 - HL 2
Fire protection for rail vehicles (DIN EN 45545-2) R24	HL 1 - HL 2

Environmental and real-life conditions

Ambient conditions

Degree of protection	IP20
Ambient temperature (operation)	-20 °C ... 65 °C
Ambient temperature (storage/transport)	-40 °C ... 85 °C

MINI MCR-SL-PT100-LP-SP - Temperature measuring transducer



2810382

<https://www.phoenixcontact.com/us/products/2810382>

Altitude	≤ 2000 m
Permissible humidity (operation)	5 % ... 95 % (non-condensing)

Approvals

CE

Certificate	CE-compliant
-------------	--------------

ATEX

Identification	⊕ II 3 G Ex nA IIC T4 Gc X
----------------	----------------------------

UL, USA/Canada

Identification	UL 508 Recognized Class I, Div. 2, Groups A, B, C, D T4
----------------	--

EMC data

Electromagnetic compatibility	Conformance with EMC directive
Noise immunity	EN 61000-6-2
Note	When being exposed to interference, there may be minimal deviations.

Noise emission

Standards/regulations	EN 61000-6-4
-----------------------	--------------

Electrostatic discharge

Standards/regulations	EN 61000-4-2
-----------------------	--------------

Electrostatic discharge

Comments	Safety measures must be taken to prevent electrostatic discharge.
----------	---

Electromagnetic HF field

Designation	Electromagnetic RF field
Standards/regulations	EN 61000-4-3
Typical deviation from the measuring range final value	5 %

Fast transients (burst)

Designation	Fast transients (burst)
Standards/regulations	EN 61000-4-4
Typical deviation from the measuring range final value	5 %

Surge current load (surge)

Standards/regulations	EN 61000-4-5
-----------------------	--------------

Surge current load (surge)

Comments	Criterion B
----------	-------------

Conducted interference

MINI MCR-SL-PT100-LP-SP - Temperature measuring transducer



2810382

<https://www.phoenixcontact.com/us/products/2810382>

Designation	Conducted interferences
Standards/regulations	EN 61000-4-6
Typical deviation from the measuring range final value	5 %

Standards and regulations

Electrical isolation	Basic insulation in accordance with EN 61010
----------------------	--

Mounting

Mounting type	DIN rail mounting
Mounting position	any

MINI MCR-SL-PT100-LP-SP - Temperature measuring transducer



2810382

<https://www.phoenixcontact.com/us/products/2810382>

Drawings

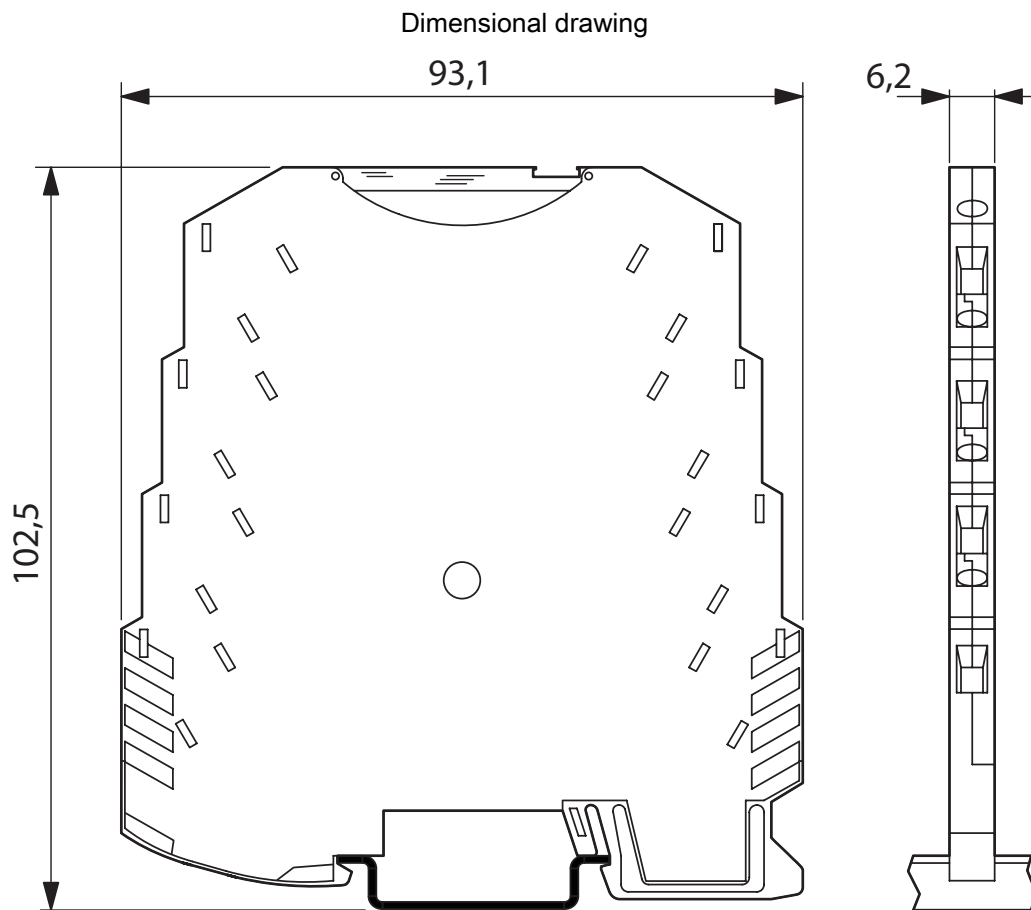

MINI MCR-SL-PT100-LP-SP - Temperature measuring transducer

2810382

<https://www.phoenixcontact.com/us/products/2810382>

Application drawing

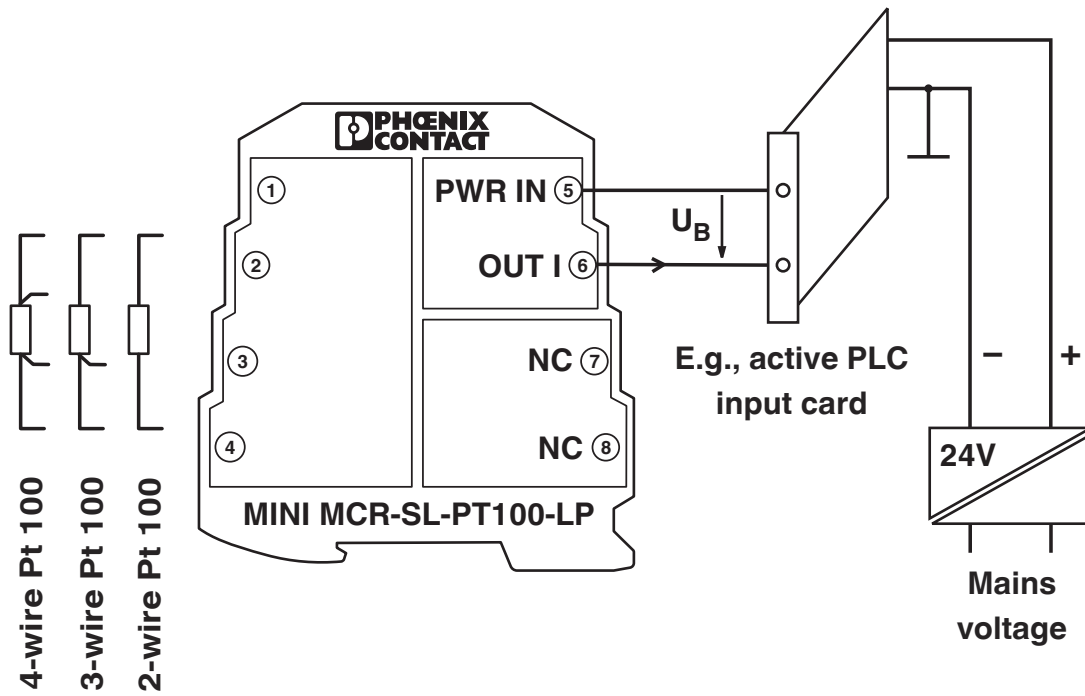

MINI MCR-SL-PT100-LP-SP - Temperature measuring transducer



2810382

<https://www.phoenixcontact.com/us/products/2810382>

Block diagram

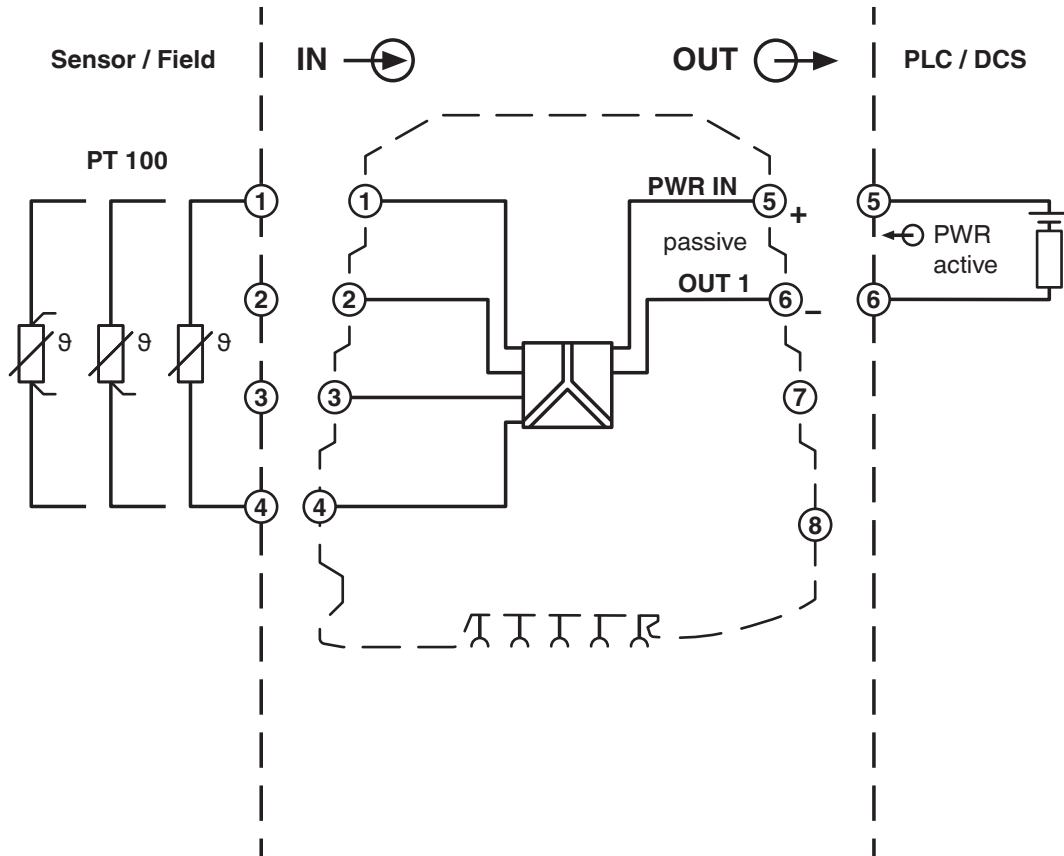

MINI MCR-SL-PT100-LP-SP - Temperature measuring transducer



2810382

<https://www.phoenixcontact.com/us/products/2810382>

Environmental product compliance

China RoHS

Environment friendly use period (EFUP)	EFUP-50
	An article-related China RoHS declaration table can be found in the download area for the respective article under "Manufacturer declaration". For all articles with EFUP-E, no China RoHS declaration table issued and required.

EU REACH SVHC

REACH candidate substance (CAS No.)	No substance above 0.1 wt%
-------------------------------------	----------------------------

Phoenix Contact 2026 © - all rights reserved
<https://www.phoenixcontact.com>

Phoenix Contact USA
586 Fulling Mill Road
Middletown, PA 17057, United States
(+717) 944-1300
info@phoenixcon.com