

VAL-MS 500 ST - Type 2 surge protection plug



2807609

<https://www.phoenixcontact.com/us/products/2807609>

Please be informed that the data shown in this PDF document is generated from our online catalog. Please find the complete data in the user documentation. Our general terms of use for downloads are valid.



Surge protection connector type 2 with high-capacity varistor for VAL-MS base element, thermal monitoring, visual fault warning. Design: 500 V AC

Your advantages

- Quality proven millions of times over in the widest range of applications
- Rapid installation with bridges, thanks to industry-standard overall width of 1 HP
- Easy testing and insulation measurement, thanks to pluggable protection modules
- Wide range of applications due to various nominal voltages
- High degree of modularity provides individual solutions for every application

Commercial data

Item number	2807609
Packing unit	10 pc
Minimum order quantity	1 pc
Sales key	CL18
Product key	CL1321
GTIN	4017918075293
Weight per piece (including packing)	61.3 g
Weight per piece (excluding packing)	60.34 g
Customs tariff number	85363010
Country of origin	DE

VAL-MS 500 ST - Type 2 surge protection plug



2807609

<https://www.phoenixcontact.com/us/products/2807609>

Technical data

Notes

Order information:	Use in DC applications on request
--------------------	-----------------------------------

General

Note	Usable in all low-voltage systems between L-N or L-PEN. Only usable in IT Systems between L-PE, if the exposed-conductive-parts (bodies) of the equipment of the low-voltage installation is connected to the earthing arrangement of the transformer substation. (interconnected earthing arrangement of the HV-transformer substation with the bodies of the LV-installation. $R_E = R_A$ accordance to IEC 60364-4-442 / VDE 0100-442 Fig. 44D / Example a)
------	--

Product properties

Product type	Replacement plug
Product family	VALVETRAB MS
IEC test classification	II T2
EN type	T2
IEC power supply system	TN IT
Type	DIN rail module, two-section, divisible
Distance between live and grounded parts	5 mm
Number of positions	1
Surge protection fault message	optical
Arrester can be tested with CHECKMASTER from software version:	From SW rev. 1.10
Number of ports	One

Insulation characteristics

Overvoltage category	III
Pollution degree	2

Electrical properties

Nominal frequency f_N	50 Hz (60 Hz)
-------------------------	---------------

Connection data

Connection method	pluggable
-------------------	-----------

Dimensions

VAL-MS 500 ST - Type 2 surge protection plug

2807609

<https://www.phoenixcontact.com/us/products/2807609>

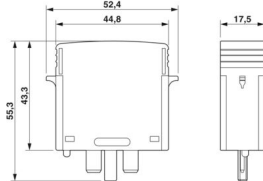
Dimensional drawing	
Width	17.5 mm
Height	52.4 mm
Depth	55.3 mm
Horizontal pitch	1 Div.

Material specifications

Color	black (RAL 9005)
Flammability rating according to UL 94	V-0
CTI value of material	600
Insulating material	PA 6.6
Material group	I
Housing material	PA 6.6

Protective circuit

Mode of protection	L-PE
	L-PEN
Direction of action	1L-N/PE
Nominal voltage U_N	400/690 V AC (TN)
	500 V AC (IT)
Nominal frequency f_N	50 Hz (60 Hz)
Maximum continuous operating voltage U_C	600 V AC
Protective conductor current I_{PE}	≤ 0.45 mA
Standby power consumption P_C	≤ 250 mVA
Nominal discharge current I_n (8/20) μ s	15 kA
Maximum discharge current I_{max} (8/20) μ s	30 kA
Short-circuit current rating I_{SCCR}	25 kA
Voltage protection level U_p	≤ 2.7 kV
Residual voltage U_{res}	≤ 2.7 kV (at I_n)
	≤ 2.5 kV (at 10 kA)
	≤ 2.3 kV (at 5 kA)
	≤ 2.2 kV (at 3 kA)
TOV behavior at U_T	690 V AC (5 s / withstand mode)
	762 V AC (120 min / withstand mode)
Response time t_A	≤ 25 ns
Max. backup fuse with branch wiring	125 A (gG)

Environmental and real-life conditions

VAL-MS 500 ST - Type 2 surge protection plug



2807609

<https://www.phoenixcontact.com/us/products/2807609>

Ambient conditions

Degree of protection	IP20
Ambient temperature (operation)	-40 °C ... 80 °C
Ambient temperature (storage/transport)	-40 °C ... 80 °C
Altitude	≤ 2000 m (amsl)
Permissible humidity (operation)	5 % ... 95 %
Shock (operation)	25g (Half-sine / 11 ms / 3x ±X, ±Y, ±Z)
Vibration (operation)	5g (10 ... 500 Hz / 2.5 h / X, Y, Z)

Approvals

UL specifications

Maximum continuous operating voltage MCOV (L-N)	600 V AC
Nominal discharge current I_n (L-N)	10 kA
Mode of protection	L-N
Nominal voltage	500 V AC
Power distribution system	Single phase
Nominal frequency	50/60 Hz
Measured limiting voltage MLV (L-N)	2370 V
SPD Type	4CA

Standards and regulations

Standards/specifications	IEC 61643-11
Note	2011
Standards/specifications	EN 61643-11
Note	2012

Mounting

Mounting type	on base element
---------------	-----------------

VAL-MS 500 ST - Type 2 surge protection plug

2807609

<https://www.phoenixcontact.com/us/products/2807609>



Drawings

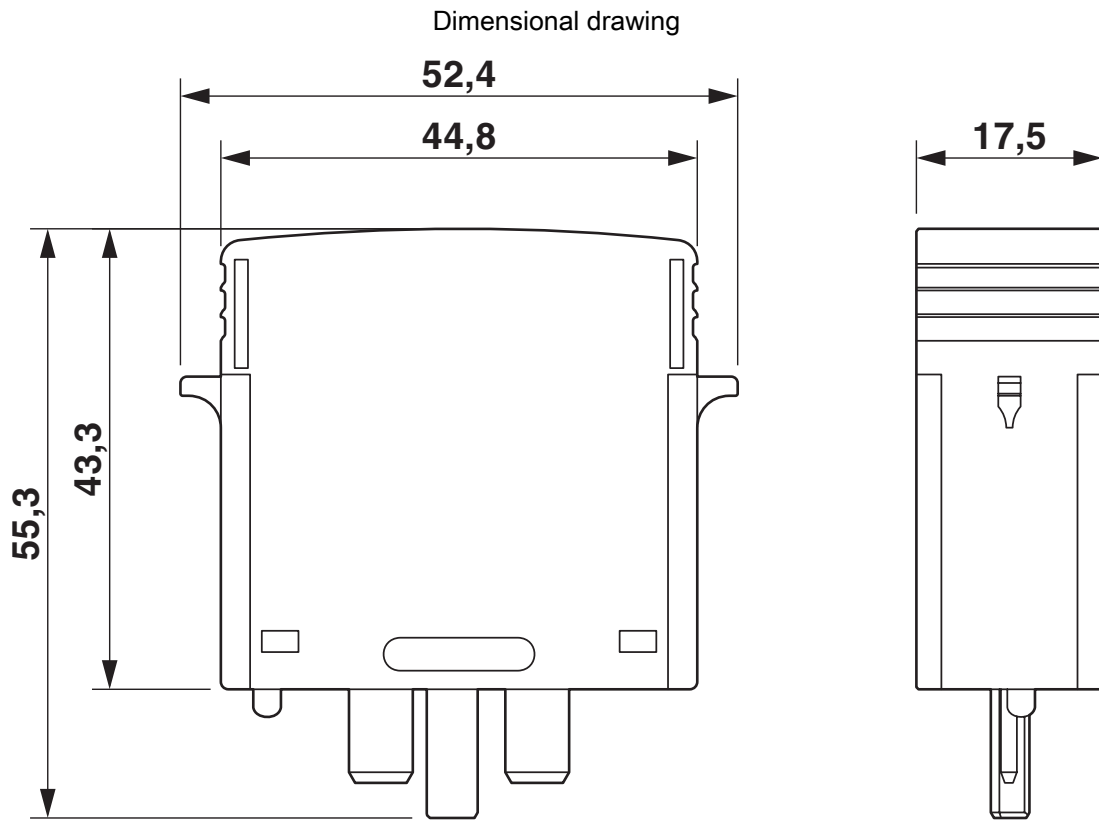

Circuit diagram



VAL-MS 500 ST - Type 2 surge protection plug



2807609

<https://www.phoenixcontact.com/us/products/2807609>

Approvals

To download certificates, visit the product detail page: <https://www.phoenixcontact.com/us/products/2807609>



cUL Recognized

Approval ID: FILE E 330181



UL Recognized

Approval ID: FILE E 330181



IECEE CB Scheme

Approval ID: AT 2905/M1

CCA

Approval ID: NTR-AT 1947-A



KEMA-KEUR

Approval ID: 71-148002



DNV GL

Approval ID: TAE000041M



CSA

Approval ID: 13631



ÖVE

Approval ID: 18583-001-17

UAE-RoHS

Approval ID: 22-09-51251



ÖVE

Approval ID: 18583-001-18

VAL-MS 500 ST - Type 2 surge protection plug



2807609

<https://www.phoenixcontact.com/us/products/2807609>

Classifications

ECLASS

ECLASS-13.0	27171292
ECLASS-15.0	27171292

ETIM

ETIM 10.0	EC002496
-----------	----------

UNSPSC

UNSPSC 21.0	39121600
-------------	----------

VAL-MS 500 ST - Type 2 surge protection plug



2807609

<https://www.phoenixcontact.com/us/products/2807609>

Environmental product compliance

EU RoHS

Fulfills EU RoHS substance requirements	Yes, No exemptions
---	--------------------

China RoHS

Environment friendly use period (EFUP)	EFUP-E
	No hazardous substances above the limits

EU REACH SVHC

REACH candidate substance (CAS No.)	No substance above 0.1 wt%
-------------------------------------	----------------------------

EF3.1 Climate Change

CO2e kg	0.714 kg CO2e
---------	---------------

Phoenix Contact 2026 © - all rights reserved
<https://www.phoenixcontact.com>

Phoenix Contact USA
586 Fulling Mill Road
Middletown, PA 17057, United States
(+717) 944-1300
info@phoenixcon.com