

VAL-MS-AR 75 VF - Type 2 surge arrester



2801487

<https://www.phoenixcontact.com/us/products/2801487>

Please be informed that the data shown in this PDF document is generated from our online catalog. Please find the complete data in the user documentation. Our general terms of use for downloads are valid.



The VAL-MS-AR 75 VF is a hybrid SPD with a gas discharge tube in series with a metal oxide varistor and thermal monitor, ideal for applications where no leakage current can be tolerated. The VAL-MS BE-AR base provides a disconnect that separates the field wire from the protected mode for field diagnosis. Independent input and output terminals are on the same side with ground terminals on the opposite end. All terminals are high-current screw clamping for stripped or ferruled, solid or stranded wires.

Your advantages

- Separate field and house wire termination
- Tool-free field wire disconnect and test point
- IP20 touch safe when connected
- VF plug has zero leakage current

Commercial data

Item number	2801487
Packing unit	10 pc
Minimum order quantity	10 pc
Note	Made to order (non-returnable)
Sales key	CL18
Product key	CL1321
GTIN	4046356879491
Weight per piece (including packing)	171.312 g
Weight per piece (excluding packing)	171.312 g
Customs tariff number	85363010
Country of origin	DE

VAL-MS-AR 75 VF - Type 2 surge arrester



2801487

<https://www.phoenixcontact.com/us/products/2801487>

Technical data

Product properties

Product type	Surge protection for NEMA power supply units
Product family	VALVETRAB MS
IEC test classification	II
	T2
EN type	T2
Type	DIN rail module, two-section, divisible
Surge protection fault message	optical

Electrical properties

Nominal frequency f_N	50 Hz (60 Hz)
Nominal voltage U_N	60 V DC (5 V ... 48 V AC)
Nominal current I_N	76 A (at 30 °C ambient temperature)

Connection data

Connection method	Screw terminal block
Tightening torque	3 Nm ... 4.5 Nm (Ground)
	1.5 Nm ... 1.8 Nm (House)
	2.5 Nm ... 3 Nm (Field)
Conductor cross-section flexible	1.5 mm ² ... 35 mm ² (16 mm strip length)
	0.5 mm ² ... 15 mm ² (10 mm strip length)
	1.5 mm ² ... 25 mm ² (14 mm strip length)
Conductor cross-section rigid	1.5 mm ² ... 35 mm ² (16 mm strip length)
	0.5 mm ² ... 15 mm ² (10 mm strip length)
	1.5 mm ² ... 25 mm ² (14 mm strip length)
Conductor cross-section AWG	15 ... 2 (16 mm strip length)
	20 ... 6 (10 mm strip length)
	12 ... 4 (14 mm strip length)

Dimensions

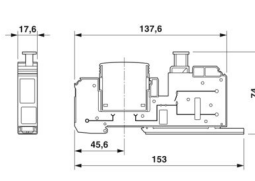
Dimensional drawing	
Width	17.7 mm
Height	153 mm
Depth	75 mm

Material specifications

Color	black (RAL 9005)
-------	------------------

VAL-MS-AR 75 VF - Type 2 surge arrester



2801487

<https://www.phoenixcontact.com/us/products/2801487>

	black (RAL 9005)
Flammability rating according to UL 94	V0
Housing material	PA

Protective circuit

Direction of action	1L-N/PE
Nominal frequency f_N	50 Hz (60 Hz)
Maximum continuous operating voltage U_C	100 V DC
	75 V AC
Rated load current I_L	55 A (with 6 AWG)
Nominal discharge current I_n (8/20) μ s	10 kA
Maximum discharge current I_{max} (8/20) μ s	20 kA
Total discharge current I_{Total} (8/20) μ s	20 kA
Total discharge current I_{Total} (10/350) μ s	3 kA
Voltage protection level U_p	≤ 1.4 kV
Total surge current (10/350) μ s	3 kA
Total surge current (8/20) μ s	25 kA
Max. backup fuse with branch wiring	63 A (gG)

Environmental and real-life conditions

Ambient conditions

Degree of protection	IP20 (when disconnect closed)
	IP20
Ambient temperature (operation)	-40 °C ... 80 °C
Altitude	max. 3000 m
Permissible humidity (operation)	5 % ... 95 %
Permissible humidity (storage/transport)	5 % ... 95 %
Shock (operation)	10g
Vibration (operation)	2g (0 Hz ... 200 Hz)

Mounting

Mounting type	DIN rail mounting with additional retaining screw
---------------	---

VAL-MS-AR 75 VF - Type 2 surge arrester



2801487

<https://www.phoenixcontact.com/us/products/2801487>

Drawings

Dimensional drawing

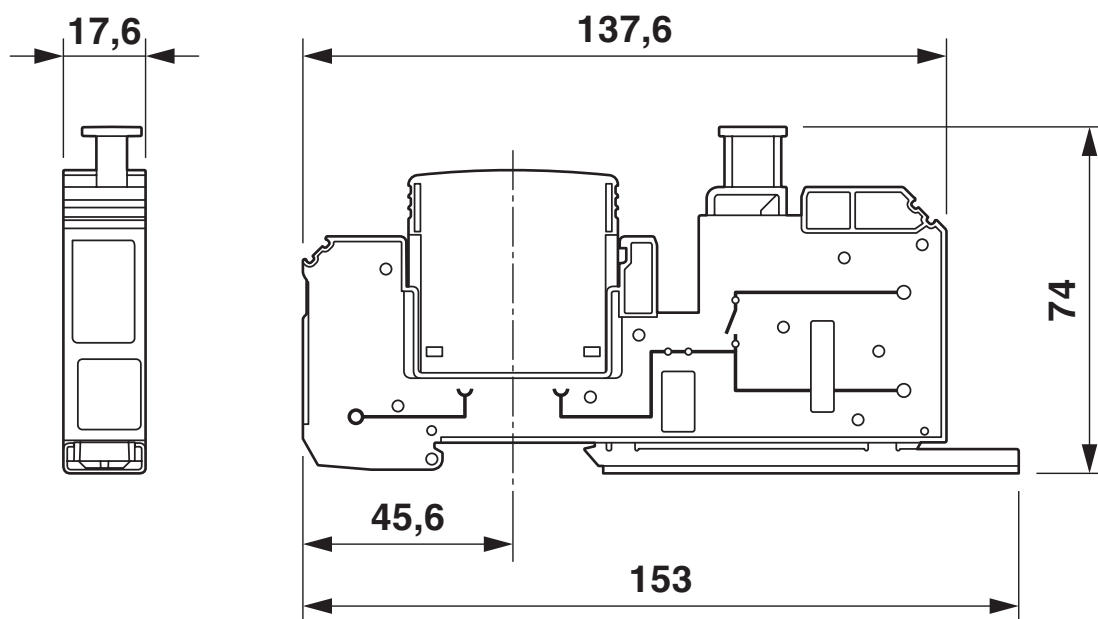

VAL-MS-AR 75 VF - Type 2 surge arrester

2801487

<https://www.phoenixcontact.com/us/products/2801487>



Circuit diagram



VAL-MS-AR 75 VF - Type 2 surge arrester



2801487

<https://www.phoenixcontact.com/us/products/2801487>

Classifications

ECLASS

ECLASS-13.0

27171202

ETIM

ETIM 9.0

EC000941

UNSPSC

UNSPSC 21.0

39121620

VAL-MS-AR 75 VF - Type 2 surge arrester



2801487

<https://www.phoenixcontact.com/us/products/2801487>

Environmental product compliance

EU RoHS

Fulfills EU RoHS substance requirements	Not applicable, Not qualified for the European market
---	---

China RoHS

Environment friendly use period (EFUP)	EFUP-50
	An article-related China RoHS declaration table can be found in the download area for the respective article under "Manufacturer declaration". For all articles with EFUP-E, no China RoHS declaration table issued and required.

EU REACH SVHC

REACH candidate substance (CAS No.)	Lead(CAS: 7439-92-1)
-------------------------------------	----------------------

Phoenix Contact 2026 © - all rights reserved
<https://www.phoenixcontact.com>

Phoenix Contact USA
586 Fulling Mill Road
Middletown, PA 17057, United States
(+717) 944-1300
info@phoenixcon.com