

CBB TM 12 2X6RC P-PT - Potential distributors



2801483

<https://www.phoenixcontact.com/us/products/2801483>

Please be informed that the data shown in this PDF document is generated from our online catalog. Please find the complete data in the user documentation. Our general terms of use for downloads are valid.

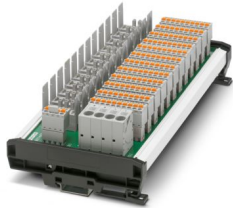

Device circuit breaker boards for twelve CB TM1... thermal-magnetic circuit breakers with group remote signaling, central supply, and potential distribution for up to five loads per channel.

Commercial data

Item number	2801483
Packing unit	1 pc
Minimum order quantity	1 pc
Sales key	CL04
Product key	CLA211
GTIN	4046356782333
Weight per piece (including packing)	787.7 g
Weight per piece (excluding packing)	780 g
Customs tariff number	85366990
Country of origin	DE

CBB TM 12 2X6RC P-PT - Potential distributors



2801483

<https://www.phoenixcontact.com/us/products/2801483>

Technical data

Product properties

Product type	Device circuit breaker board
Type	DIN rail module, two-section, divisible
Number of positions	1
No. of channels	12

Insulation characteristics

Overvoltage category	II
Degree of pollution	2

Electrical properties

Fuse type	Automatic device
Maximum load current	60 A (Complete main circuit)
Maximum current with single arrangement	12 A (per channel)

General

Rated insulation voltage U_i	50 V DC
Rated surge voltage	0.5 kV
Short-circuit current rating	600 A (conditional according to DIN EN 50178)
Power dissipation	4.5 W (with even load on outputs with In)
Insertion/withdrawal cycles	50

Main circuit

Rated voltage	24 V DC
Rated current I_N	60 A DC (total) 12 A DC (per channel)

Remote indication circuit

Rated voltage	24 V DC
Rated current I_N	1 A DC

Connection data

Maximum load current	60 A (Complete main circuit)
----------------------	------------------------------

Supply X21

Connection method	Push-in connection
Stripping length	18 mm
Conductor cross-section flexible min.	0.75 mm ²
Conductor cross-section flexible max.	16 mm ²
Conductor cross-section, rigid min.	0.75 mm ²
Conductor cross-section, rigid max.	16 mm ²

Outputs X1 ... X12

Connection method	Push-in connection
-------------------	--------------------

CBB TM 12 2X6RC P-PT - Potential distributors

2801483

<https://www.phoenixcontact.com/us/products/2801483>

Stripping length	10 mm
Conductor cross-section flexible min.	0.2 mm ²
Conductor cross-section flexible max.	2.5 mm ²
Conductor cross-section, rigid min.	0.2 mm ²
Conductor cross-section, rigid max.	2.5 mm ²

Remote signaling X31

Connection method	Push-in connection
Stripping length	10 mm
Conductor cross-section flexible min.	0.2 mm ²
Conductor cross-section flexible max.	2.5 mm ²
Conductor cross-section, rigid min.	0.2 mm ²
Conductor cross-section, rigid max.	2.5 mm ²

Dimensions

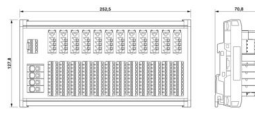
Dimensional drawing	
Width	252.5 mm
Height	127.8 mm
Depth	70.8 mm

Material specifications

Color	gray (RAL 7042)
	black (RAL 9005)
Flammability rating according to UL 94	V0

Mechanical properties

Mechanical data

Open side panel	No
-----------------	----

Environmental and real-life conditions

Ambient conditions

Degree of protection	IP20 (Terminal blocks and fuse holders)
	IP00 (PCB)
Ambient temperature (operation)	-30 °C ... 60 °C (at In 60 A)
Ambient temperature (storage/transport)	-30 °C ... 80 °C

Standards and regulations

Standards/specifications	DIN EN 50178
Note	1997

Mounting

CBB TM 12 2X6RC P-PT - Potential distributors



2801483

<https://www.phoenixcontact.com/us/products/2801483>

Mounting type	DIN rail: 35 mm
Mounting position	horizontal

CBB TM 12 2X6RC P-PT - Potential distributors

2801483

<https://www.phoenixcontact.com/us/products/2801483>

Drawings

Dimensional drawing

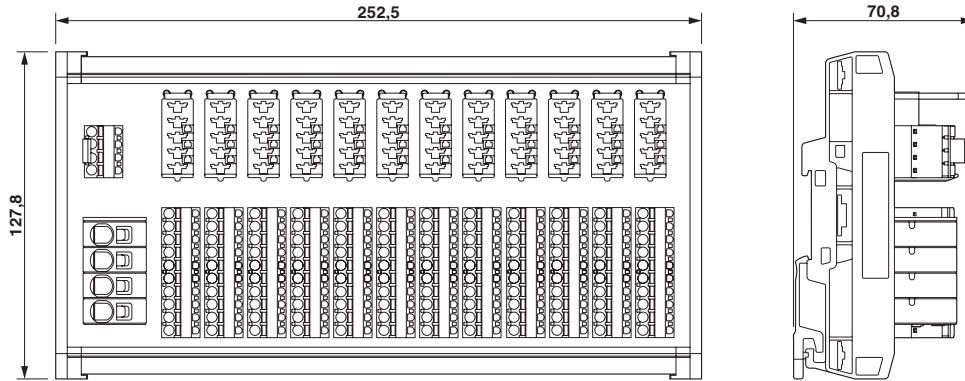

Application drawing

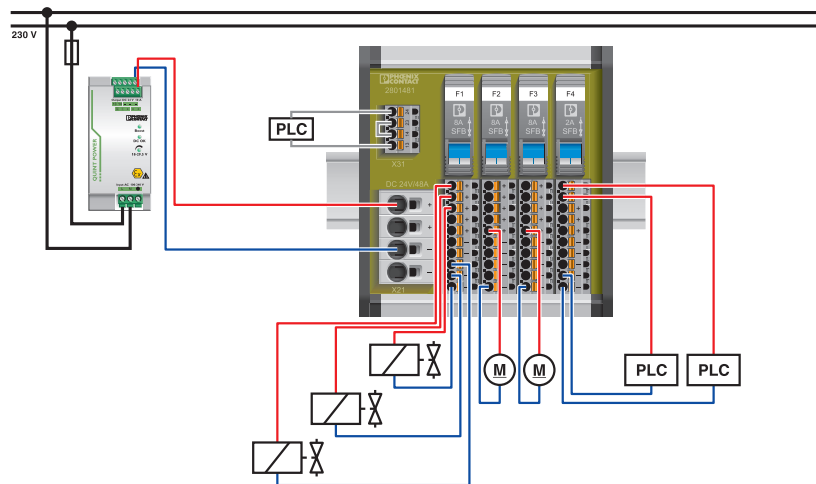

Circuit diagram

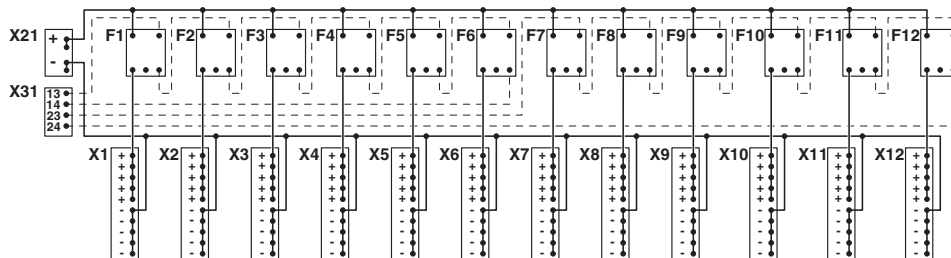

CBB TM 12 2X6RC P-PT - Potential distributors



2801483

<https://www.phoenixcontact.com/us/products/2801483>

Classifications

ECLASS

ECLASS-13.0	27371392
ECLASS-15.0	27371392

ETIM

ETIM 10.0	EC002886
-----------	----------

UNSPSC

UNSPSC 21.0	39121100
-------------	----------

CBB TM 12 2X6RC P-PT - Potential distributors



2801483

<https://www.phoenixcontact.com/us/products/2801483>

Environmental product compliance

EU RoHS

Fulfills EU RoHS substance requirements	Yes, No exemptions
---	--------------------

China RoHS

Environment friendly use period (EFUP)	EFUP-E
	No hazardous substances above the limits

EU REACH SVHC

REACH candidate substance (CAS No.)	No substance above 0.1 wt%
-------------------------------------	----------------------------

Phoenix Contact 2026 © - all rights reserved
<https://www.phoenixcontact.com>

Phoenix Contact USA
586 Fulling Mill Road
Middletown, PA 17057, United States
(+717) 944-1300
info@phoenixcon.com