

PT-IQ-1X2-48DC-PT - Surge protection device



2801257

<https://www.phoenixcontact.com/us/products/2801257>

Please be informed that the data shown in this PDF document is generated from our online catalog. Please find the complete data in the user documentation. Our general terms of use for downloads are valid.



Surge protection, consisting of protective plug and base element, with integrated multi-stage status indicator on the module, for a 2-wire floating signal circuit. Can be used in safety-related circuits up to SIL 3.

Your advantages

- Predictive monitoring with 3-stage LED display
- Integration of the status message into the system controller via group remote signaling
- Install quickly and error-free with DIN rail connectors
- Maximum ease of maintenance, thanks to the 2-piece design
- Maximum protection for MCR applications with high discharge capacity

Commercial data

Item number	2801257
Packing unit	1 pc
Minimum order quantity	1 pc
Sales key	CL22
Product key	CL2153
GTIN	4046356766401
Weight per piece (including packing)	110 g
Weight per piece (excluding packing)	110 g
Customs tariff number	85363030
Country of origin	DE

Technical data

Notes

General

Note	Remote signaling as well as the power supply of the DIN rail connector are established by snapping the module into place on the DIN rail connector.
------	---

Product properties

Product type	Surge protection for MCR technology
Product family	PLUGTRAB IQ
IEC test classification	C1
	C2
	C3
	D1
Type	DIN rail module, two-section, divisible
Surge protection fault message	Optical, multi-stage
Wire pairs per module	1

Insulation characteristics

Overvoltage category	III
Pollution degree	2

Electrical properties

Nominal voltage U_N	48 V DC
-----------------------	---------

Connection data

Connection method	Push-in connection
Conductor cross-section flexible	0.2 mm ² ... 2.5 mm ²
Conductor cross-section rigid	0.2 mm ² ... 4 mm ²
Conductor cross-section AWG	24 ... 12

Dimensions

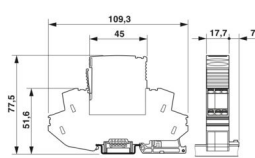
Dimensional drawing	
Width	17.7 mm
Height	109.3 mm
Depth	77.5 mm (incl. DIN rail 7.5 mm)
Horizontal pitch	1 Div.

Material specifications

PT-IQ-1X2-48DC-PT - Surge protection device



2801257

<https://www.phoenixcontact.com/us/products/2801257>

Color	black (RAL 9005)
	black (RAL 9005)
Flammability rating according to UL 94	V-0
Housing material	PA 6.6

Mechanical properties

Mechanical data

Open side panel	No
-----------------	----

Protective circuit

Direction of action	Line-Line & Line-Signal Ground/Shield & optional Signal Ground/Shield-Earth Ground
Nominal voltage U_N	48 V DC
Maximum continuous operating voltage U_C	53 V DC
	37 V AC
Rated current	300 mA
Operating effective current I_C at U_C	$\leq 5 \mu\text{A}$ (in the signal circuit)
Protective conductor current I_{PE}	$\leq 2 \mu\text{A}$ (per signal circuit)
Nominal discharge current I_n (8/20) μs (line-line)	10 kA
Nominal discharge current I_n (8/20) μs (line-ground)	10 kA
Pulse discharge current I_{imp} (10/350) μs (line-earth)	2.5 kA
Total discharge current I_{Total} (8/20) μs	20 kA
Voltage protection level U_p (line-line)	$\leq 100 \text{ V}$ (C1 - 1 kV / 500 A)
	$\leq 150 \text{ V}$ (C2 - 10 kV / 5 kA)
	$\leq 90 \text{ V}$ (C3 - 25 A)
	$\leq 95 \text{ V}$ (C3 - 100 A)
Voltage protection level U_p (line-earth)	$\leq 600 \text{ V}$ (C1 - 1 kV / 500 A)
	$\leq 750 \text{ V}$ (C2 - 10 kV / 5 kA)
	$\leq 700 \text{ V}$ (C3 - 25 A)
	$\leq 800 \text{ V}$ (C3 - 100 A)
Voltage protection level U_p static (line-earth)	$\leq 60 \text{ V}$ (C2 - 10 kV / 5 kA)
	$\leq 40 \text{ V}$ (C3 - 25 A)
	$\leq 100 \text{ V}$ (C3 - 100 A)
Response time t_A (line-line)	$\leq 1 \text{ ns}$
Response time t_A (line-earth)	$\leq 100 \text{ ns}$
Input attenuation aE, sym.	typ. 0.3 dB ($\leq 450 \text{ kHz}/150 \Omega$)
Cut-off frequency f_g (3 dB), sym. in 150 Ω system	typ. 1.9 MHz
Capacity (Core-Core)	typ. 1.5 nF
Resistance per path	1.2 $\Omega \pm 5 \%$
Surge protection fault message	Optical, multi-stage
Max. required back-up fuse	315 mA (FF)
Impulse durability (line-line)	C1 - 1 kV / 500 A
	C2 - 10 kV / 5 kA
	C2 - 10 kA

PT-IQ-1X2-48DC-PT - Surge protection device



2801257

<https://www.phoenixcontact.com/us/products/2801257>

	C3 - 100 A
Impulse durability (line-earth)	C1 - 1 kV / 500 A
	C2 - 10 kV / 5 kA
	C2 - 10 kA
	C3 - 100 A
	D1 - 2.5 kA
Pulse reset time (line-line)	≤ 300 ms
Pulse reset time (line-earth)	≤ 4000 ms

Environmental and real-life conditions

Ambient conditions

Degree of protection	IP20
Ambient temperature (operation)	-40 °C ... 70 °C
Ambient temperature (storage/transport)	-40 °C ... 85 °C
Altitude	≤ 4000 m (amsl)

Standards and regulations

Standards/specifications	IEC 61643-21
Note	2000 + A1:2008 + A2:2012
Standards/specifications	EN 61643-21
Note	2001 + A1:2009 + A2:2013
Standards/specifications	EN 61000-6-2
Note	2005
Standards/specifications	EN 61000-6-3
Note	2007 + A1:2011

Mounting

Mounting type	DIN rail: 35 mm
---------------	-----------------

PT-IQ-1X2-48DC-PT - Surge protection device



2801257

<https://www.phoenixcontact.com/us/products/2801257>

Drawings

Dimensional drawing

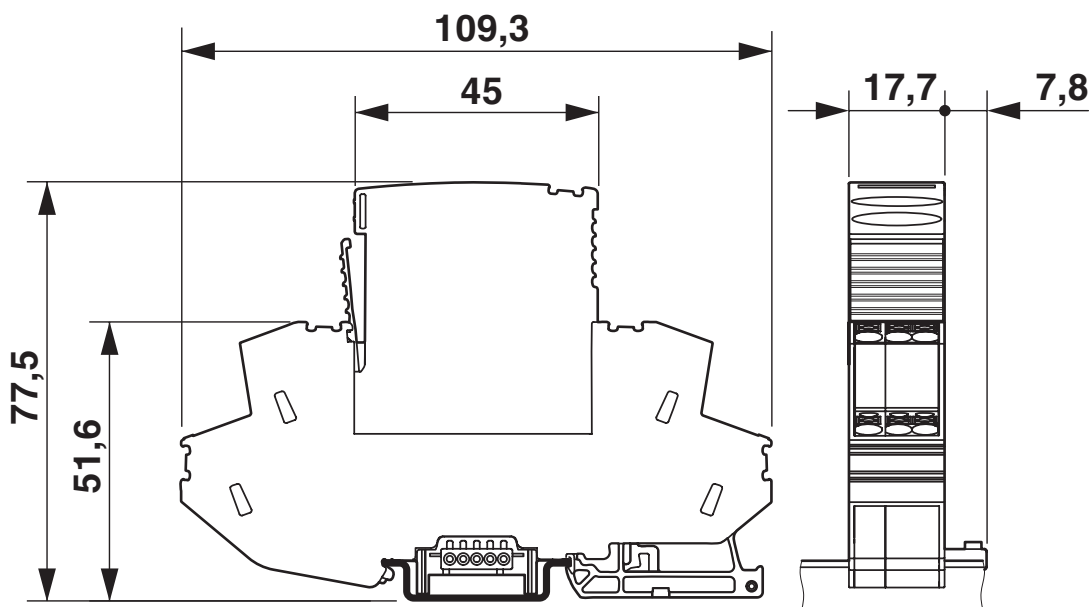

Schematic diagram

PT-IQ-1X2-...DC-UT(PT)									
Category	1oo1 architecture, HFT=0				1oo2 architecture, HFT=1				
	PFD _{AVG}	PFH	Used budget of SIL 2 SIF		PFD _{AVG}	PFH	CCF	Used budget of SIL 3 SIF	
			PFD _{AVG}	PFH				PFD _{AVG}	PFH
	1.07·10 ⁻⁵	1.90·10 ⁻⁹ 1/h	0.1 %	0.2 %	5.34·10 ⁻⁷	9.50·10 ⁻¹¹ 1/h	5 %	0.1 %	0.1 %
					1.07·10 ⁻⁶	1.90·10 ⁻¹⁰ 1/h	10 %	0.1 %	0.2 %
Calculation based on exida report, Phoenix Contact 13/04-032 R017 V4R0 exida Profile 1, FMEDA Analysis 2, T _{proof} : 1 year, MT: 10 years, MTTR: 24 hours, PTC: 99% Used standards IEC/EN 61508, edition 2010 (device specific) IEC/EN 61511, edition 2016 + COR1:2016 + A1:2017 (system specific)									

Functional safety scenarios

PT-IQ-1X2-48DC-PT - Surge protection device



2801257

<https://www.phoenixcontact.com/us/products/2801257>

Circuit diagram

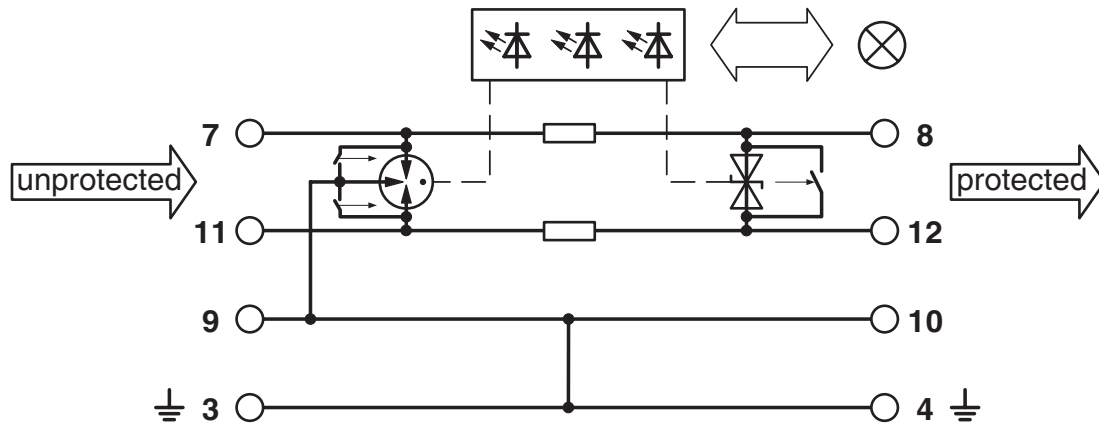

PT-IQ-1X2-48DC-PT - Surge protection device



2801257

<https://www.phoenixcontact.com/us/products/2801257>

Approvals

To download certificates, visit the product detail page: <https://www.phoenixcontact.com/us/products/2801257>



CSA

Approval ID: 2761632



UL Listed

Approval ID: FILE E 138168



CSAus

Approval ID: 2761632

Functional Safety

Approval ID: 13-04-032 R017 V4R0

PT-IQ-1X2-48DC-PT - Surge protection device



2801257

<https://www.phoenixcontact.com/us/products/2801257>

Classifications

ECLASS

ECLASS-13.0	27171501
ECLASS-15.0	27171501

ETIM

ETIM 10.0	EC001466
-----------	----------

UNSPSC

UNSPSC 21.0	39121600
-------------	----------

2801257

<https://www.phoenixcontact.com/us/products/2801257>

Environmental product compliance

EU RoHS

Fulfills EU RoHS substance requirements	Yes
Exemption	6(c), 7(a), 7(c)-I

China RoHS

Environment friendly use period (EFUP)	EFUP-50
	An article-related China RoHS declaration table can be found in the download area for the respective article under "Manufacturer declaration". For all articles with EFUP-E, no China RoHS declaration table issued and required.

EU REACH SVHC

REACH candidate substance (CAS No.)	Lead(CAS: 7439-92-1)
	2,2',6,6'-tetrabromo-4,4'-isopropylidenediphenol(CAS: 79-94-7)
SCIP	c6334c80-9511-4879-831a-9e3ec521f84a

Phoenix Contact 2026 © - all rights reserved
<https://www.phoenixcontact.com>

Phoenix Contact USA
586 Fulling Mill Road
Middletown, PA 17057, United States
(+717) 944-1300
info@phoenixcon.com