

# CB E1 24DC/3A S-C P - Electronic circuit breaker



2800924

<https://www.phoenixcontact.com/us/products/2800924>

Please be informed that the data shown in this PDF document is generated from our online catalog. Please find the complete data in the user documentation. Our general terms of use for downloads are valid.



Electronic circuit breaker, 1-pos., active current limitation, status output and control input, plug for base element.

## Your advantages

- Individually adjustable with protective plugs
- Protective plug with fixed nominal current value as protection against unintentional changes
- Active current limitation to improve the capacity of the upstream power supply
- Remote switch-on and switch-off thanks to the controller function
- Increased system transparency with integrated remote message function

## Commercial data

Item number	2800924
Packing unit	1 pc
Minimum order quantity	1 pc
Sales key	CL04
Product key	CLA134
GTIN	4046356690805
Weight per piece (including packing)	35.2 g
Weight per piece (excluding packing)	35.2 g
Customs tariff number	85362010
Country of origin	DE

# CB E1 24DC/3A S-C P - Electronic circuit breaker



2800924

<https://www.phoenixcontact.com/us/products/2800924>

## Technical data

### Product properties

Product type	Device circuit breakers
Product family	CB E
Type	Male
Number of positions	1
No. of channels	1

### Insulation characteristics

Degree of pollution	2
---------------------	---

### Electrical properties

#### General

Operating voltage	24 V DC
	18 V DC ... 30 V DC
Nominal current $I_N$	3 A
Rated surge voltage	0.5 kV
Tripping method	E (electronic)
Required backup fuse	not required, integrated failsafe element
Dielectric strength	max. 30 V DC (Load circuit)
Active current limitation	typ. $1.25 \times I_N$
Fuse	electronic
Closed circuit current $I_0$	typ. 8 mA (When switched on)
	typ. 11 mA (With status output)
Power dissipation	0.62 W (Nominal operation)
Temperature derating	3 A (at 50 °C)
MTBF (IEC 61709, SN 29500)	8320000 h (at 25 °C with 80 % load)
	7410000 h (at 40 °C with 80 % load)
Voltage drop	120 mV (at $I_N$ )
Fail-safe element	6 A DC
Contact switching type	without electrical isolation

#### Load circuit

Shutdown time	300 ms (see time/current characteristic curve)
Undervoltage switch-off	< 14 V (typ. OFF)
	> 17 V (typ. ON)
Max. capacitive load	20000 $\mu$ F
Switch-on delay	typ. 2 ms

#### Auxiliary contact

Contact connection type	Positive-switching signal output
-------------------------	----------------------------------

#### Status output

Output voltage	24 V DC
----------------	---------

# CB E1 24DC/3A S-C P - Electronic circuit breaker



2800924

<https://www.phoenixcontact.com/us/products/2800924>

Output current	max. 0.2 A (Short-circuit-proof)
----------------	----------------------------------

## Connection data

Connection method	pluggable
-------------------	-----------

## Dimensions

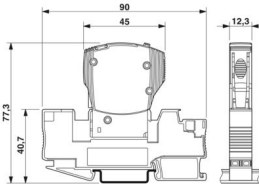
Dimensional drawing	
Width	12.3 mm
Height	45 mm
Depth	52 mm
Complete module width	12.3 mm
Complete module height	90 mm
Complete module depth	77.3 mm

## Material specifications

Color	gray (RAL 7042)
	black (RAL 9005)
Flammability rating according to UL 94	V-0

## Environmental and real-life conditions

### Ambient conditions

Degree of protection	IP30 (Actuation area)
Ambient temperature (operation)	-25 °C ... 50 °C (non-condensing)
Ambient temperature (storage/transport)	-40 °C ... 70 °C
Humidity test	96 h, 95 % RH, 40 °C
Vibration (operation)	3g (according to IEC 60068-2-6, Test Fc)

## Approvals

### UL approval

Identification	UL Listed UL 508
	UL Recognized UL 2367

### Shipbuilding approval

Identification	DNV GL
----------------	--------

## Standards and regulations

Standard designation	EMV
Standards/specifications	EN 61000-6-3
Note	Interference emission

# CB E1 24DC/3A S-C P - Electronic circuit breaker



2800924

<https://www.phoenixcontact.com/us/products/2800924>

Standard designation	EMV
Standards/specifications	EN 61000-6-2
Note	Noise immunity

## Mounting

Mounting type	on base element
---------------	-----------------

# CB E1 24DC/3A S-C P - Electronic circuit breaker



2800924

<https://www.phoenixcontact.com/us/products/2800924>

## Drawings



The figure shows the complete module consisting of a base element and connector



Diagram



Trigger characteristic

Circuit diagram

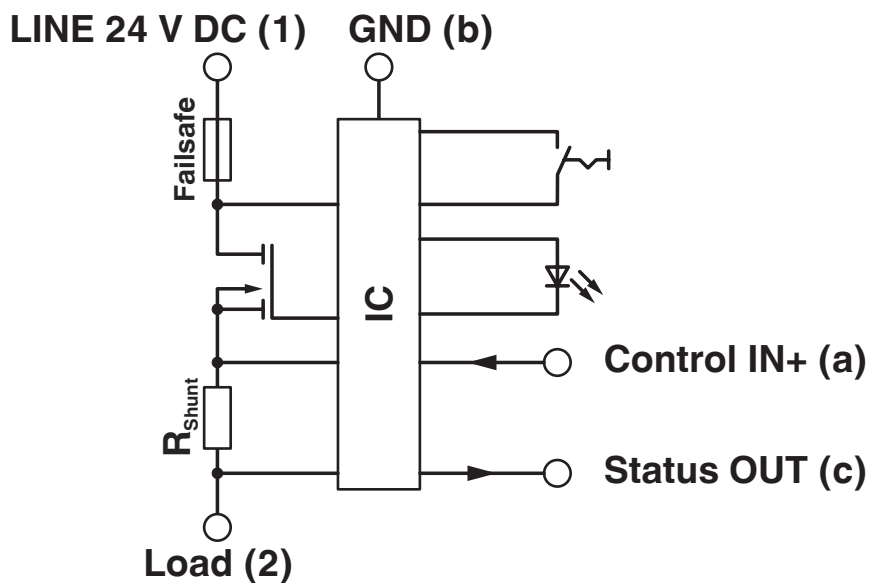

# CB E1 24DC/3A S-C P - Electronic circuit breaker



2800924

<https://www.phoenixcontact.com/us/products/2800924>

## Approvals

To download certificates, visit the product detail page: <https://www.phoenixcontact.com/us/products/2800924>



**UL Recognized**

Approval ID: FILE E 317172



**DNV GL**

Approval ID: TAE00003KA



**cULus Listed**

Approval ID: E123528

# CB E1 24DC/3A S-C P - Electronic circuit breaker



2800924

<https://www.phoenixcontact.com/us/products/2800924>

## Classifications

### ECLASS

ECLASS-13.0	27140401
ECLASS-15.0	27140401

### ETIM

ETIM 10.0	EC003538
-----------	----------

### UNSPSC

UNSPSC 21.0	39121400
-------------	----------

2800924

<https://www.phoenixcontact.com/us/products/2800924>

## Environmental product compliance

### EU RoHS

Fulfills EU RoHS substance requirements	Yes
Exemption	7(a), 7(c)-I

### China RoHS

Environment friendly use period (EFUP)	EFUP-25
	An article-related China RoHS declaration table can be found in the download area for the respective article under "Manufacturer declaration". For all articles with EFUP-E, no China RoHS declaration table issued and required.

### EU REACH SVHC

REACH candidate substance (CAS No.)	Lead(CAS: 7439-92-1)
SCIP	804f8026-26a5-4b63-aa40-205722fdbe7b

### EF3.1 Climate Change

CO2e kg	2.961 kg CO2e
---------	---------------

Phoenix Contact 2026 © - all rights reserved  
<https://www.phoenixcontact.com>

Phoenix Contact USA  
586 Fulling Mill Road  
Middletown, PA 17057, United States  
(+717) 944-1300  
[info@phoenixcon.com](mailto:info@phoenixcon.com)