

PT-IQ-5-HF-12DC-UT - Surge protection device



2800799

<https://www.phoenixcontact.com/us/products/2800799>

Please be informed that the data shown in this PDF document is generated from our online catalog. Please find the complete data in the user documentation. Our general terms of use for downloads are valid.



Surge protection, consisting of protective plug and base element, with integrated multi-stage status indicator on the module for five signal wires. For HF applications and telecommunications interfaces without supply voltage (up to 90 Mbps). Can be used in safety-related circuits up to SIL 3.

Your advantages

- Predictive monitoring with 3-stage LED display
- Integration of the status message into the system controller via group remote signaling
- Install quickly and error-free with DIN rail connectors
- Maximum ease of maintenance, thanks to the 2-piece design
- Maximum protection for MCR applications with high discharge capacity

Commercial data

Item number	2800799
Packing unit	1 pc
Minimum order quantity	1 pc
Note	Made to order (non-returnable)
Sales key	CL22
Product key	CL2151
GTIN	4046356665216
Weight per piece (including packing)	123.3 g
Weight per piece (excluding packing)	123.3 g
Customs tariff number	85363010
Country of origin	DE

PT-IQ-5-HF-12DC-UT - Surge protection device



2800799

<https://www.phoenixcontact.com/us/products/2800799>

Technical data

Notes

General

Note	Remote signaling as well as the power supply of the DIN rail connector are established by snapping the module into place on the DIN rail connector.
------	---

Product properties

Product type	Surge protection for information technology
Product family	PLUGTRAB IQ
IEC test classification	C1
	C2
	C3
	D1
Type	DIN rail module, two-section, divisible
Surge protection fault message	Optical, multi-stage

Insulation characteristics

Overvoltage category	III
Pollution degree	2

Electrical properties

Nominal voltage U_N	12 V DC
-----------------------	---------

Connection data

Connection method	Screw connection
Screw thread	M3
Tightening torque	0.5 Nm
Conductor cross-section flexible	0.2 mm ² ... 2.5 mm ²
Conductor cross-section rigid	0.2 mm ² ... 4 mm ²
Conductor cross-section AWG	24 ... 12

Interfaces

Transmission speed	90 Mbps
--------------------	---------

Dimensions

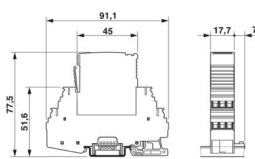
Dimensional drawing	
Width	17.7 mm
Height	91 mm

PT-IQ-5-HF-12DC-UT - Surge protection device



2800799

<https://www.phoenixcontact.com/us/products/2800799>

Depth	77.5 mm (incl. DIN rail 7.5 mm)
Horizontal pitch	1 Div.

Material specifications

Flammability rating according to UL 94	V-0
Housing material	PA 6.6

Mechanical properties

Mechanical data

Open side panel	No
-----------------	----

Protective circuit

Direction of action	Line-Line & Line-Signal Ground/Shield & optional Signal Ground/Shield-Earth Ground
Nominal voltage U_N	12 V DC
Maximum continuous operating voltage U_C	15 V DC
	10 V AC
Rated current	600 mA (40 °C)
Operating effective current I_C at U_C	$\leq 100 \mu\text{A}$ (per path)
Protective conductor current I_{PE}	$\leq 100 \mu\text{A}$ (per path)
Nominal discharge current I_n (8/20) μs (line-line)	10 kA
Nominal discharge current I_n (8/20) μs (line-ground)	10 kA
Pulse discharge current I_{imp} (10/350) μs (line-earth)	2.5 kA
Total discharge current I_{Total} (8/20) μs	20 kA
Voltage protection level U_p (line-line)	$\leq 90 \text{ V}$ (C1 - 1 kV / 500 A)
	$\leq 145 \text{ V}$ (C2 - 10 kV / 5 kA)
	$\leq 40 \text{ V}$ (C3 - 25 A)
	$\leq 40 \text{ V}$ (C3 - 50 A)
Voltage protection level U_p (line-earth)	$\leq 90 \text{ V}$ (C1 - 1 kV / 500 A)
	$\leq 145 \text{ V}$ (C2 - 10 kV / 5 kA)
	$\leq 40 \text{ V}$ (C3 - 25 A)
	$\leq 40 \text{ V}$ (C3 - 50 A)
Voltage protection level U_p static (line-line)	$\leq 55 \text{ V}$ (C1 - 1 kV / 500 A)
Voltage protection level U_p static (line-earth)	$\leq 55 \text{ V}$ (C1 - 1 kV / 500 A)
Response time t_A (line-line)	$\leq 1 \text{ ns}$
Response time t_A (line-earth)	$\leq 1 \text{ ns}$
Input attenuation aE, sym.	typ. 0.3 dB ($\leq 10 \text{ MHz}/150 \Omega$)
Input attenuation aE, asym.	typ. 0.3 dB ($\leq 10 \text{ MHz}/150 \Omega$)
Cut-off frequency f_g (3 dB), sym. in 150 Ω system	typ. 60 MHz
Cut-off frequency f_g (3 dB), asym. (signal ground) in 150 Ω system	typ. 60 MHz
Capacity (Core-Core)	typ. 30 pF
Capacitance (line-signal ground)	typ. 30 pF
Resistance per path	1.2 $\Omega \pm 5 \%$

PT-IQ-5-HF-12DC-UT - Surge protection device



2800799

<https://www.phoenixcontact.com/us/products/2800799>

Surge protection fault message	Optical, multi-stage
Max. required back-up fuse	600 mA (FF)
Impulse durability (line-line)	C1 - 1 kV / 500 A
	C2 - 10 kV / 5 kA
	C2 - 10 kA
	C3 - 50 A
Impulse durability (line-earth)	C1 - 1 kV / 500 A
	C2 - 10 kV / 5 kA
	C2 - 10 kA
	C3 - 50 A
	D1 - 2.5 kA
Impulse durability (line-signal ground)	C1 - 1 kV / 500 A
	C2 - 10 kV / 5 kA
	C2 - 10 kA
	C3 - 50 A
Pulse reset time (line-line)	≤ 15 ms
Pulse reset time (line-earth)	≤ 15 ms

Environmental and real-life conditions

Ambient conditions

Degree of protection	IP20
Ambient temperature (operation)	-40 °C ... 70 °C
Ambient temperature (storage/transport)	-40 °C ... 85 °C
Altitude	≤ 4000 m (amsl)
Permissible humidity (operation)	5 % ... 95 %

Standards and regulations

Air clearances and creepage distances

Standards/regulations	IEC 60664-1
Standards/specifications	IEC 61643-21
Note	2000 + A1:2008 + A2:2012
Standards/specifications	EN 61643-21
Note	2001 + A1:2009 + A2:2013
Standards/specifications	EN 61000-6-2
Note	2005
Standards/specifications	EN 61000-6-3
Note	2007 + A1:2011

Mounting

Mounting type	DIN rail: 35 mm
---------------	-----------------

PT-IQ-5-HF-12DC-UT - Surge protection device



2800799

<https://www.phoenixcontact.com/us/products/2800799>

Drawings

Dimensional drawing

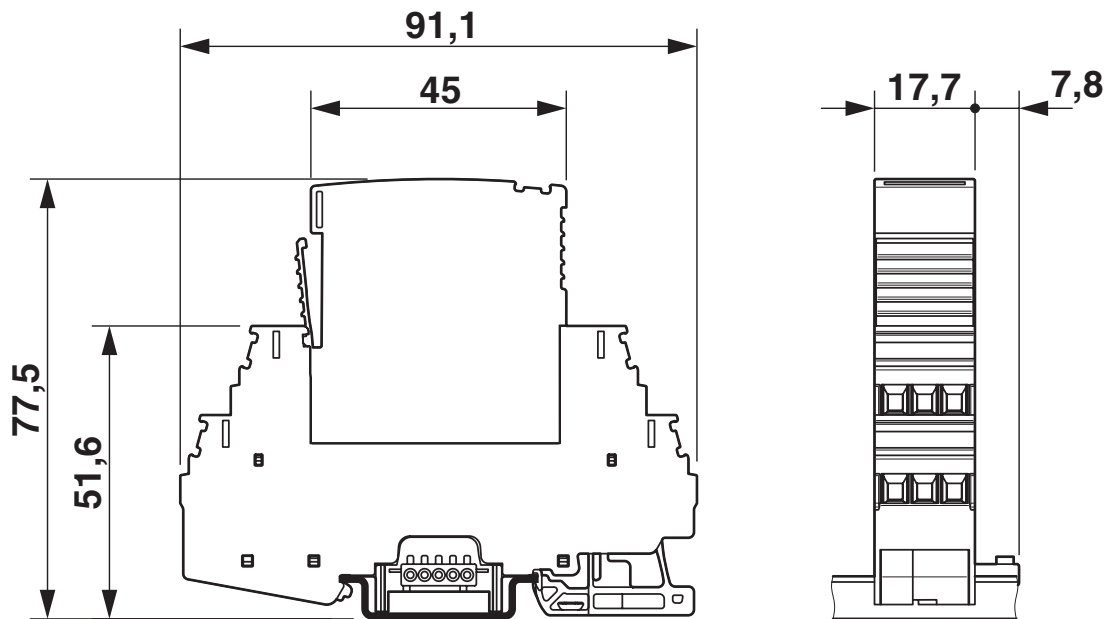

Application drawing

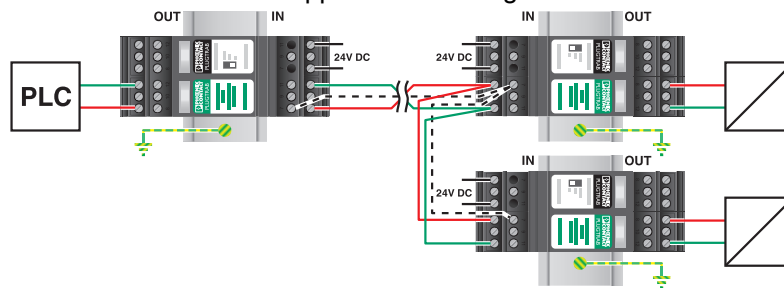

Diagram



Circuit diagram

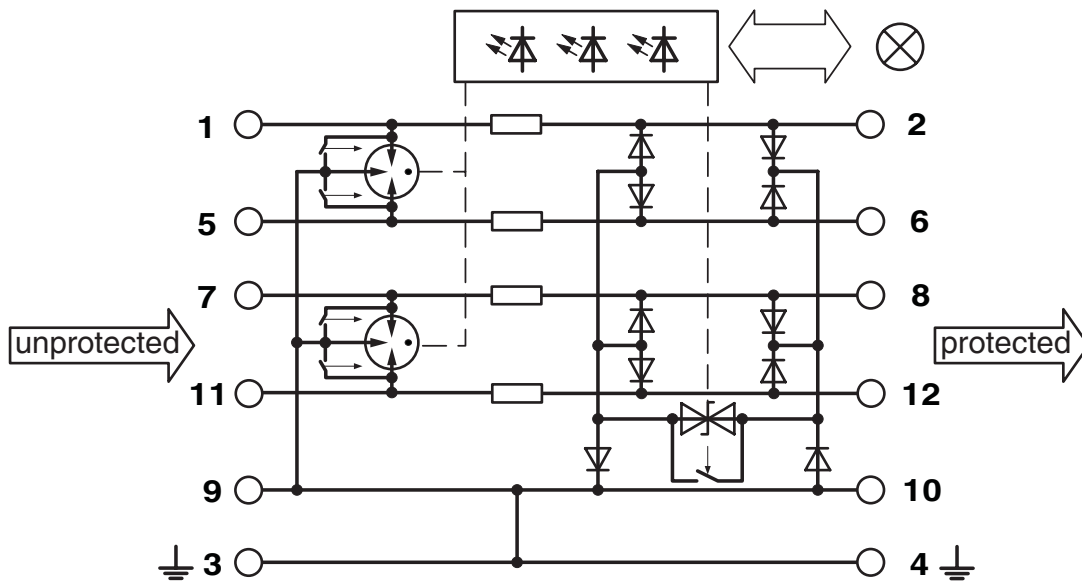

PT-IQ-5-HF-12DC-UT - Surge protection device



2800799

<https://www.phoenixcontact.com/us/products/2800799>

Classifications

UNSPSC

UNSPSC 21.0	39121600
-------------	----------

2800799

<https://www.phoenixcontact.com/us/products/2800799>

Environmental product compliance

EU RoHS

Fulfills EU RoHS substance requirements	Yes
Exemption	6(c), 7(a), 7(c)-I

China RoHS

Environment friendly use period (EFUP)	EFUP-50
	An article-related China RoHS declaration table can be found in the download area for the respective article under "Manufacturer declaration". For all articles with EFUP-E, no China RoHS declaration table issued and required.

EU REACH SVHC

REACH candidate substance (CAS No.)	Lead(CAS: 7439-92-1)
SCIP	35c58fcc-8783-46e3-b166-0aeae744aed6

Phoenix Contact 2026 © - all rights reserved

<https://www.phoenixcontact.com>

Phoenix Contact USA
586 Fulling Mill Road
Middletown, PA 17057, United States
(+717) 944-1300
info@phoenixcon.com