

# OPTOSUB-PLUS-K/OUT - FO converters



2799610

<https://www.phoenixcontact.com/us/products/2799610>

Please be informed that the data shown in this PDF document is generated from our online catalog. Please find the complete data in the user documentation. Our general terms of use for downloads are valid.



The figure shows version OPTOSUB-PLUS-G/OUT and OPTOSUB-PLUS-K/OUT

INTERBUS/fiber optic adapter, for converting the remote OUT interface to polymer/PCF fiber, connection system: F-SMA

## Commercial data

Item number	2799610
Packing unit	1 pc
Note	Made to order (non-returnable)
Sales key	DN06
Product key	DNC281
GTIN	4017918129705
Weight per piece (including packing)	43.6 g
Weight per piece (excluding packing)	30.68 g
Customs tariff number	85176200
Country of origin	DE

## Technical data

### Product properties

Product type	Media converter
--------------	-----------------

### Electrical properties

#### Supply

Nominal supply voltage	none, supply from data channel
Typical current consumption	typ. 30 mA

### Interfaces

Signal	INTERBUS
Transmission channels	2 (1/1), Rx/D, Tx/D, full duplex

#### Data: optical FO

Transmission power	354.81 $\mu$ W (-4.5 dBm at 980/1000 $\mu$ m)
	11.22 $\mu$ W (-19.5 dBm at 200/230 $\mu$ m)
Transmission length incl. 3 dB system reserve	50 m (F-P 980/1000 230 dB/km with quick mounting connector)
	300 m (with F-S 200/230 10 dB/km)
	100 m (F-S 200/230 10 dB/km, OPTOSUB/FO bus terminal module)
Connection method	F-SMA
Wavelength	660 nm
Minimum receiver sensitivity	-26 dBm
Transmission medium	Polymer fiber
	PCF fiber

#### Data: RS-485 interface INTERBUS in acc. with DIN 50254

Serial transmission speed	500 kbps
Connection method	D-SUB 9 plug
Transmission medium	Copper

### Dimensions

Width	16.3 mm
Height	57 mm
Depth	31.3 mm

### Material specifications

Material (Housing)	ABS (metal-plated)
--------------------	--------------------

### Cable/line

#### FO cable

Fiber types	200/230 $\mu$ m
	980/1000 $\mu$ m

# OPTOSUB-PLUS-K/OUT - FO converters



2799610

<https://www.phoenixcontact.com/us/products/2799610>

	PCF fiber
	Polymer fiber

## Environmental and real-life conditions

### Ambient conditions

Ambient temperature (operation)	0 °C ... 55 °C
---------------------------------	----------------

# OPTOSUB-PLUS-K/OUT - FO converters

2799610

<https://www.phoenixcontact.com/us/products/2799610>

## Drawings

Connection diagram

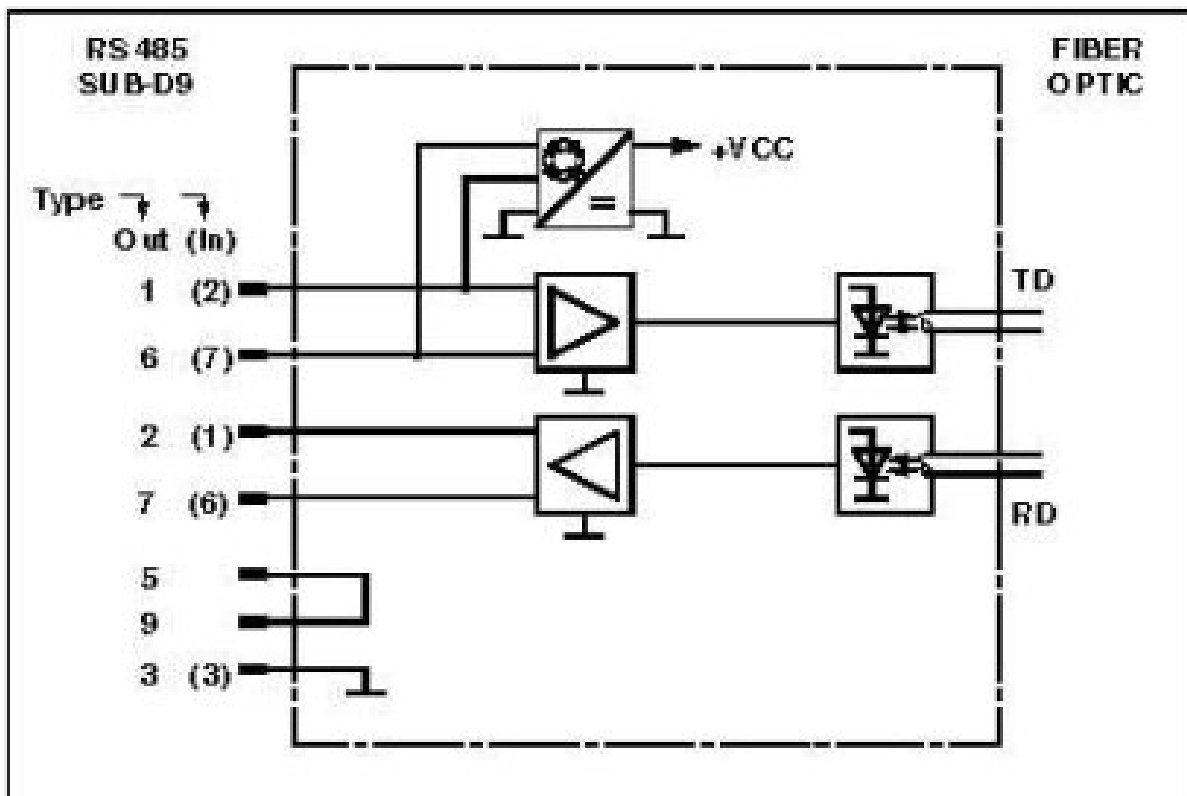

# OPTOSUB-PLUS-K/OUT - FO converters



2799610

<https://www.phoenixcontact.com/us/products/2799610>

## Classifications

### UNSPSC

UNSPSC 21.0	43223323
-------------	----------

# OPTOSUB-PLUS-K/OUT - FO converters



2799610

<https://www.phoenixcontact.com/us/products/2799610>

## Environmental product compliance

### EU RoHS

Fulfills EU RoHS substance requirements	Yes, No exemptions
---	--------------------

### China RoHS

Environment friendly use period (EFUP)	EFUP-E
	No hazardous substances above the limits

### EU REACH SVHC

REACH candidate substance (CAS No.)	No substance above 0.1 wt%
-------------------------------------	----------------------------

Phoenix Contact 2026 © - all rights reserved  
<https://www.phoenixcontact.com>

Phoenix Contact USA  
586 Fulling Mill Road  
Middletown, PA 17057, United States  
(+717) 944-1300  
[info@phoenixcon.com](mailto:info@phoenixcon.com)