

# UEGM 25-FS/FS - Electronics housing



2792086

<https://www.phoenixcontact.com/us/products/2792086>

Please be informed that the data shown in this PDF document is generated from our online catalog. Please find the complete data in the user documentation. Our general terms of use for downloads are valid.



Electronic housing, for PCB insertion, fully equipped with 3 screw or 6 tab connections per side

The figure shows version UEGM 22,5-FS/FS

## Commercial data

Item number	2792086
Packing unit	10 pc
Minimum order quantity	1 pc
Sales key	AC11
Product key	ACHCCB
GTIN	4017918072551
Weight per piece (including packing)	64.66 g
Weight per piece (excluding packing)	62.64 g
Customs tariff number	85369010
Country of origin	DE

## Technical data

### Product properties

Product type	Complete housing
Housing type	Component housing
Housing type	Basic housing
Housing series	UEGM
Product family	UEGM 25
Type	Connection system integrated, housing closed
Number of positions	12
Ventilation openings present	no

### Electrical properties

Nominal voltage $U_N$	500 V (Voltage and current values are affected by the configuration of the printed circuit board.)
Nominal current $I_N$	10 A (6.3 mm slip-on connection)
	8 A (2.8 mm slip-on connection)

### Dimensions

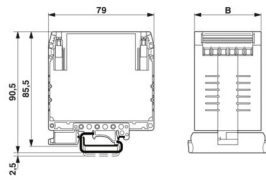
Dimensional drawing	
Width	25 mm
Installed height	85.5 mm
Height NS 35/7,5	85.5 mm
Depth	101 mm
Length	101 mm

### Material specifications

Color (Housing)	green (RAL 6021)
Material Housing	PA
Flammability rating according to UL 94	V2

### Environmental and real-life conditions

#### Ambient conditions

Ambient temperature (operation)	-40 °C ... 105 °C
---------------------------------	-------------------

### Mounting

Mounting type	DIN rail mounting
---------------	-------------------

# UEGM 25-FS/FS - Electronics housing

2792086

<https://www.phoenixcontact.com/us/products/2792086>



## Drawings

Dimensional drawing

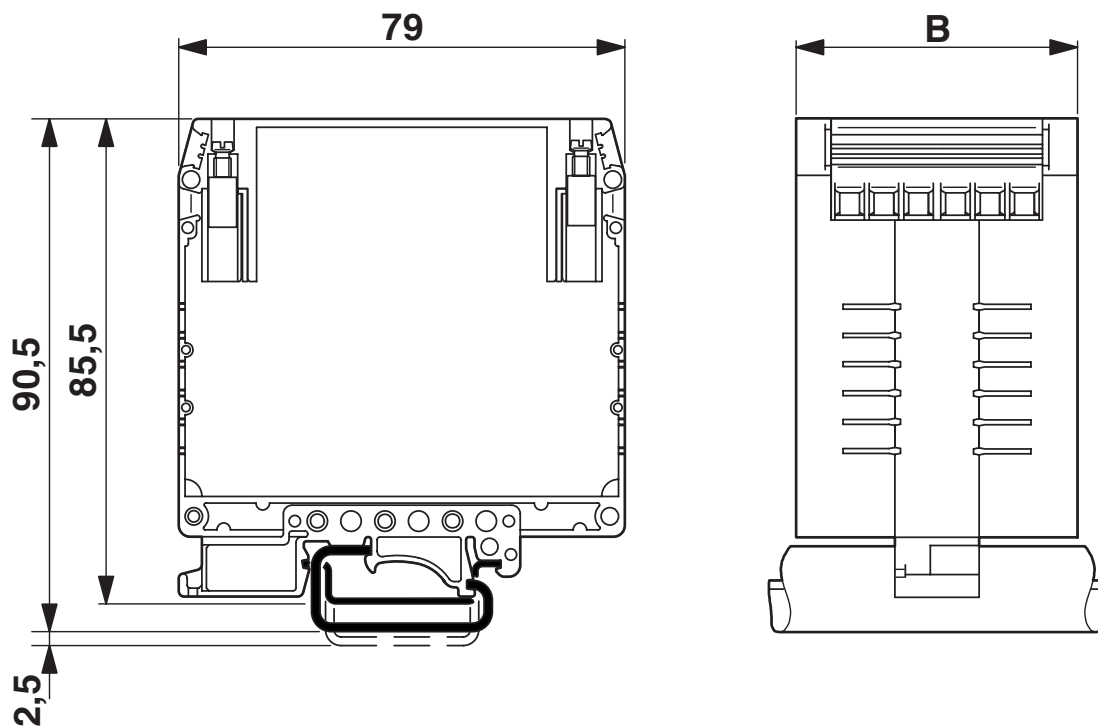

# UEGM 25-FS/FS - Electronics housing



2792086

<https://www.phoenixcontact.com/us/products/2792086>

Dimensional drawing

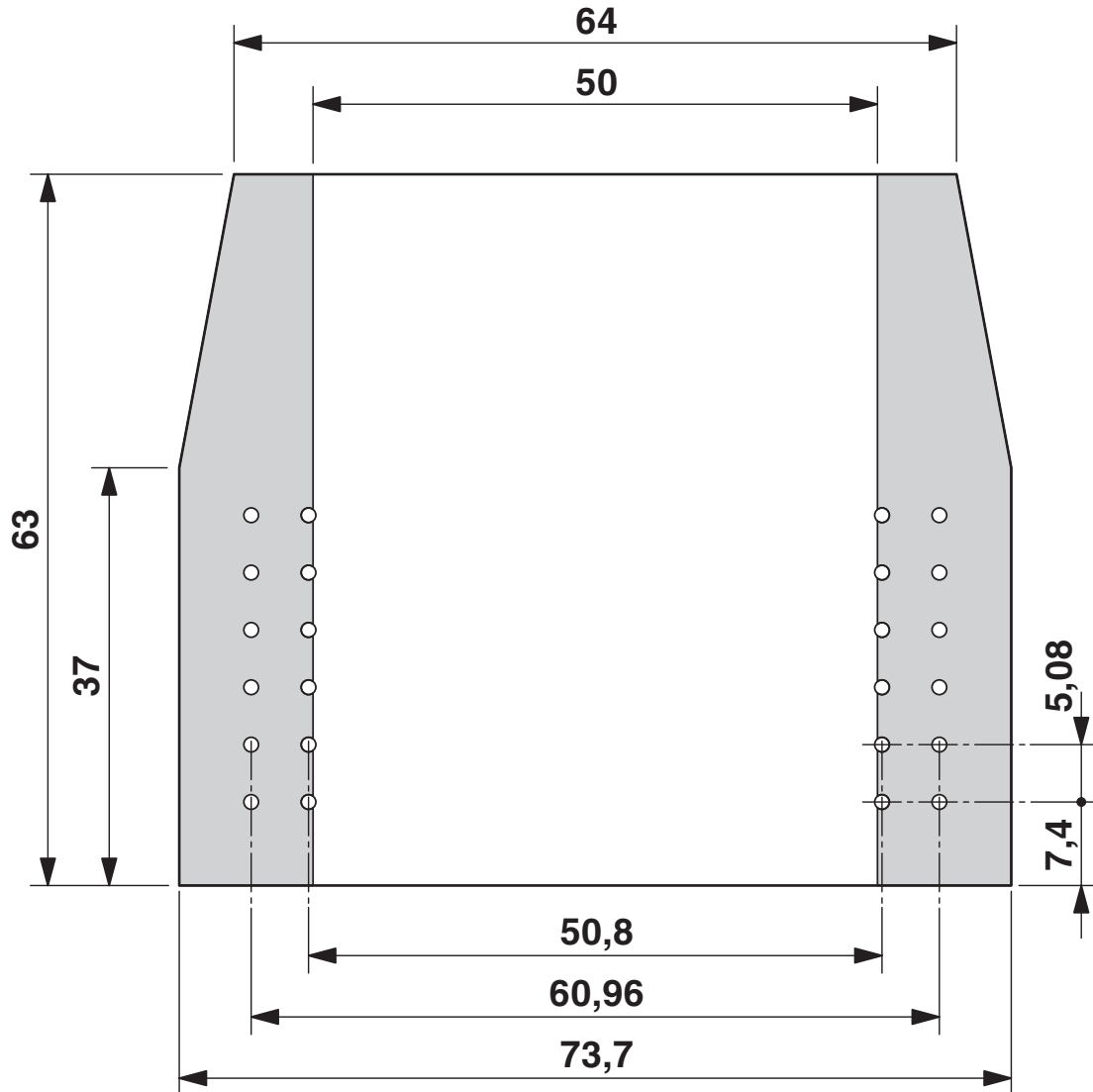

# UEGM 25-FS/FS - Electronics housing

2792086

<https://www.phoenixcontact.com/us/products/2792086>



Exploded view

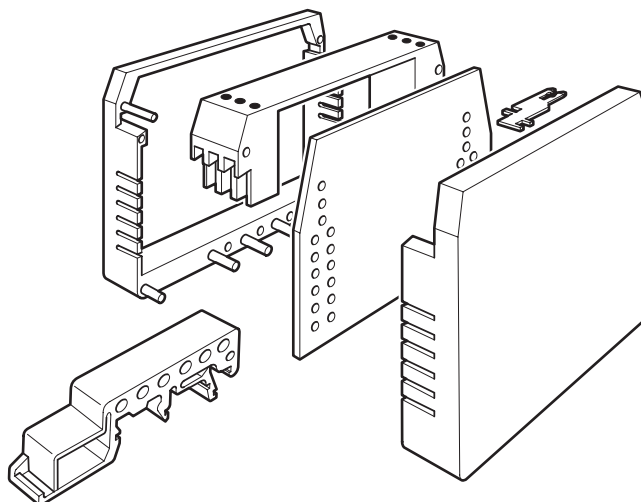

Schematic diagram

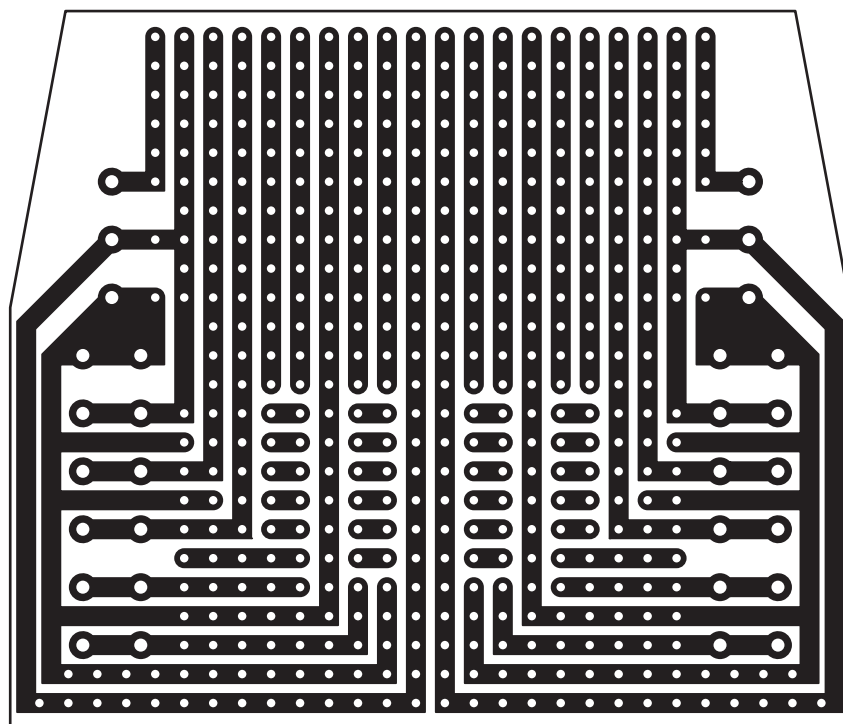

# UEGM 25-FS/FS - Electronics housing



2792086

<https://www.phoenixcontact.com/us/products/2792086>

## Approvals

To download certificates, visit the product detail page: <https://www.phoenixcontact.com/us/products/2792086>



**UL Recognized**

Approval ID: E240868

# UEGM 25-FS/FS - Electronics housing



2792086

<https://www.phoenixcontact.com/us/products/2792086>

## Classifications

### ECLASS

ECLASS-13.0	27190501
ECLASS-15.0	27190501

### ETIM

ETIM 10.0	EC001031
-----------	----------

### UNSPSC

UNSPSC 21.0	31261500
-------------	----------

# UEGM 25-FS/FS - Electronics housing



2792086

<https://www.phoenixcontact.com/us/products/2792086>

## Environmental product compliance

### EU RoHS

Fulfills EU RoHS substance requirements	Yes, No exemptions
---	--------------------

### China RoHS

Environment friendly use period (EFUP)	EFUP-E
	No hazardous substances above the limits

### EU REACH SVHC

REACH candidate substance (CAS No.)	No substance above 0.1 wt%
-------------------------------------	----------------------------

Phoenix Contact 2026 © - all rights reserved  
<https://www.phoenixcontact.com>

Phoenix Contact USA  
586 Fulling Mill Road  
Middletown, PA 17057, United States  
(+717) 944-1300  
[info@phoenixcon.com](mailto:info@phoenixcon.com)