

# UEG 30/1-FS/FS - Electronics housing

2790884

<https://www.phoenixcontact.com/us/products/2790884>

Please be informed that the data shown in this PDF document is generated from our online catalog. Please find the complete data in the user documentation. Our general terms of use for downloads are valid.

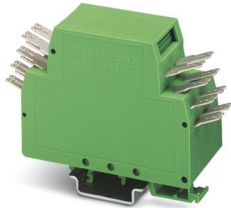

Electronic housing, for PCB insertion, fully equipped with 4 screw or tab connections per side

The figure shows version UEG 30/2 FS  
FS

## Your advantages

- Universal P1-UEG... PCBs are available for laboratory samples and small series
- Cost-effective series production, since the base element and the assembled PCB are soldered by machine
- Installation of one or two PCBs in the housing
- Efficient assembly thanks to overlapping housing parts

## Commercial data

Item number	2790884
Packing unit	1 pc
Note	Made to order (non-returnable)
Sales key	AC11
Product key	ACHCCA
GTIN	4017918072377
Weight per piece (including packing)	59.44 g
Weight per piece (excluding packing)	59.44 g
Customs tariff number	85369010
Country of origin	DE

# UEG 30/1-FS/FS - Electronics housing

2790884

<https://www.phoenixcontact.com/us/products/2790884>

## Technical data

### Product properties

Product type	Complete housing
Housing type	Complete housing
Product family	UEG
Type	Connection system integrated, housing closed
Number of positions	8

### Electrical properties

Nominal voltage $U_N$	500 V (Voltage and current values are affected by the configuration of the printed circuit board.)
Nominal current $I_N$	10 A (6.3 mm slip-on connection)
	8 A (2.8 mm slip-on connection)

### Dimensions

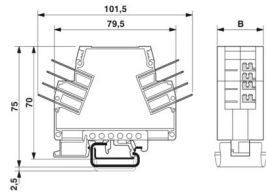
Dimensional drawing	
Width	30 mm
Installed height	70 mm
Height NS 35/7,5	70 mm
Depth	101.5 mm
Length	101.5 mm

### Material specifications

Color	green
Flammability rating according to UL 94	V2
Housing material	PA 6.6

### Environmental and real-life conditions

#### Ambient conditions

Ambient temperature (operation)	-40 °C ... 105 °C
---------------------------------	-------------------

# UEG 30/1-FS/FS - Electronics housing

2790884

<https://www.phoenixcontact.com/us/products/2790884>



## Drawings

Dimensional drawing

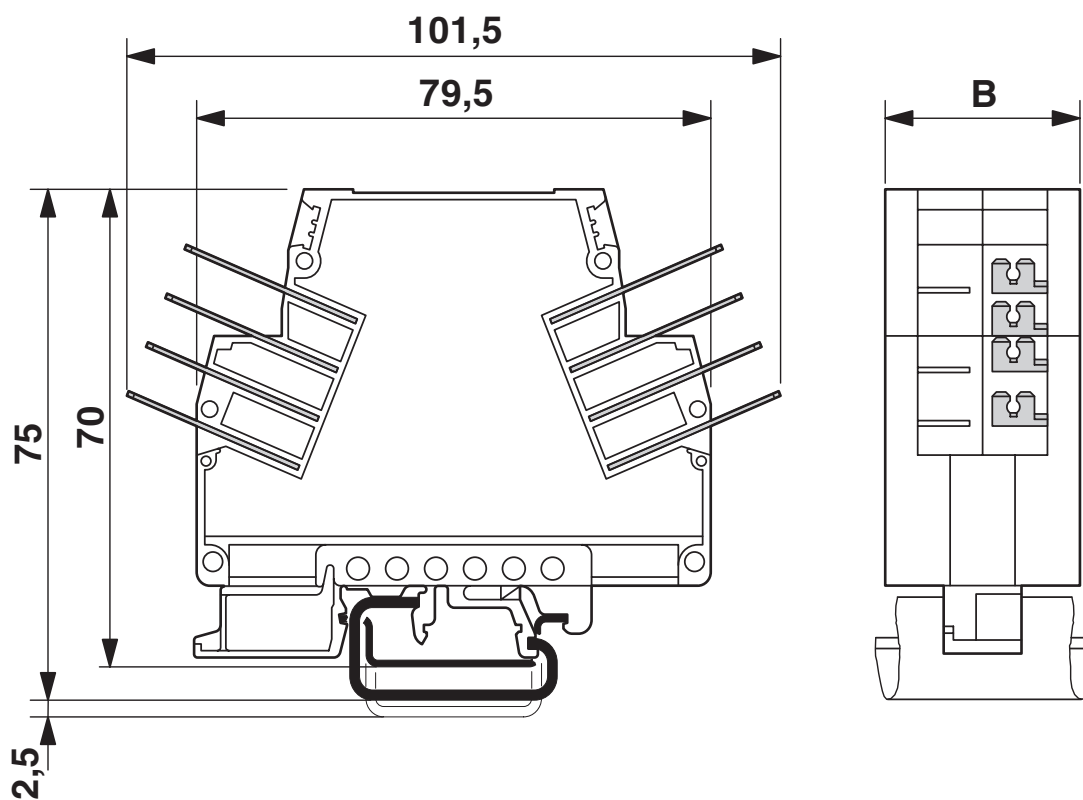

Dimensional drawing

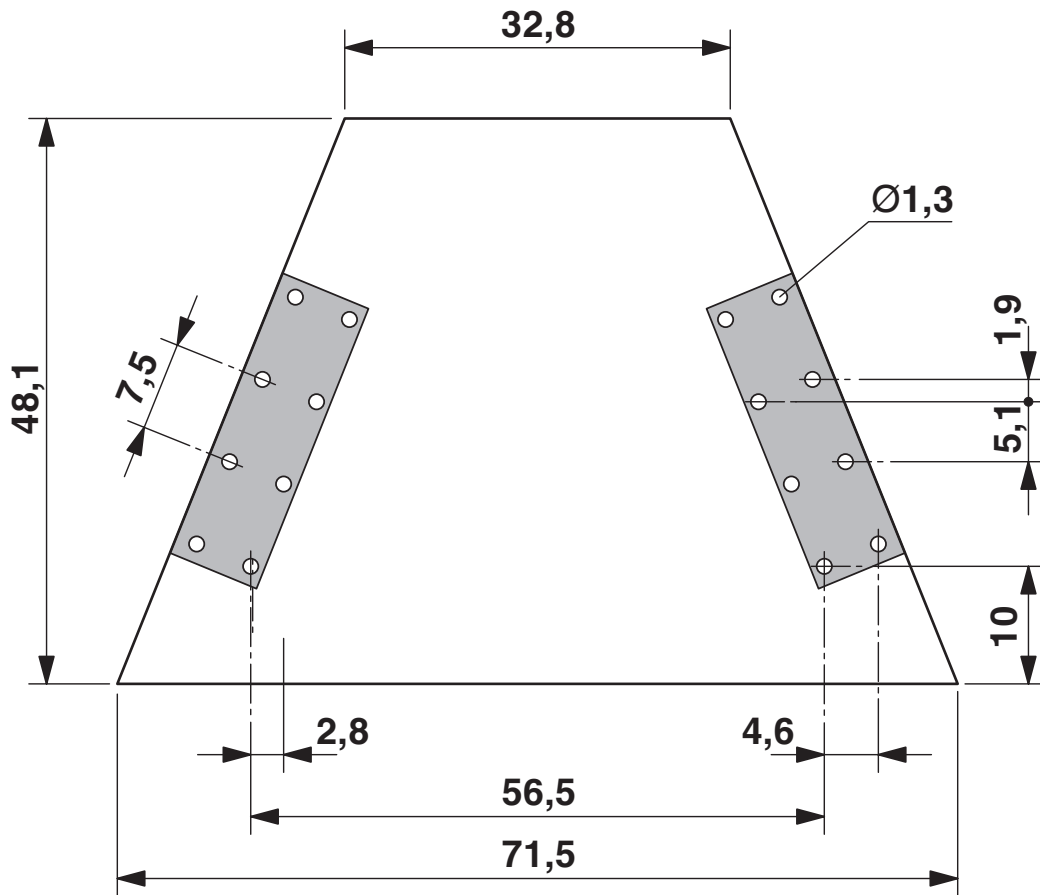

Exploded view

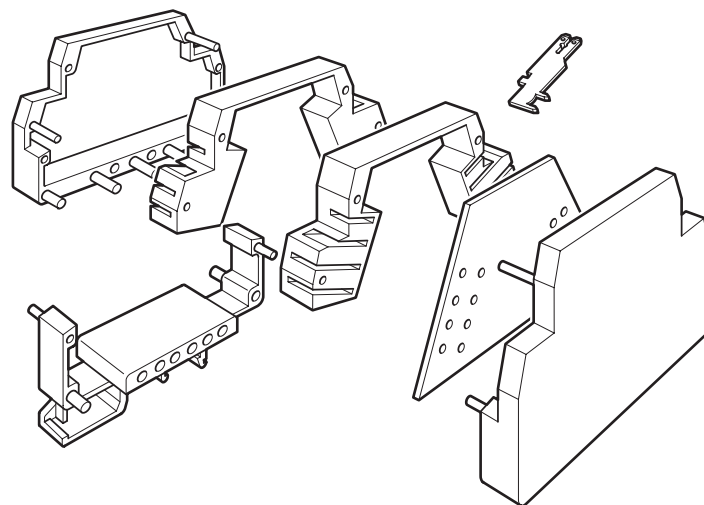

Schematic diagram

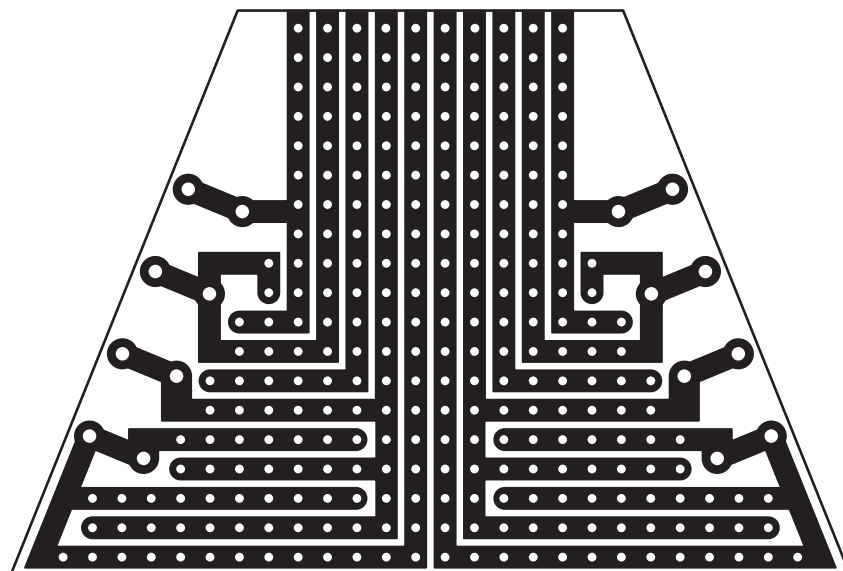

# UEG 30/1-FS/FS - Electronics housing



2790884

<https://www.phoenixcontact.com/us/products/2790884>

## Environmental product compliance

### EU RoHS

Fulfills EU RoHS substance requirements	Yes, No exemptions
---	--------------------

### China RoHS

Environment friendly use period (EFUP)	EFUP-E
	No hazardous substances above the limits

### EU REACH SVHC

REACH candidate substance (CAS No.)	No substance above 0.1 wt%
-------------------------------------	----------------------------

Phoenix Contact 2026 © - all rights reserved  
<https://www.phoenixcontact.com>

Phoenix Contact USA  
586 Fulling Mill Road  
Middletown, PA 17057, United States  
(+717) 944-1300  
[info@phoenixcon.com](mailto:info@phoenixcon.com)