

# P 1-UEG-FS/FS - Auxiliary contactor



2790428

<https://www.phoenixcontact.com/us/products/2790428>

Please be informed that the data shown in this PDF document is generated from our online catalog. Please find the complete data in the user documentation. Our general terms of use for downloads are valid.

PCB for custom fitting electronic components

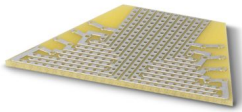

## Commercial data

Item number	2790428
Packing unit	1 pc
Note	Made to order (non-returnable)
Sales key	AC11
Product key	ACHCCZ
GTIN	4017918072346
Weight per piece (including packing)	7.47 g
Weight per piece (excluding packing)	7.274 g
Customs tariff number	85340019
Country of origin	DE

# P 1-UEG-FS/FS - Auxiliary contactor



2790428

<https://www.phoenixcontact.com/us/products/2790428>

## Technical data

### Product properties

Product type	PCB
--------------	-----

# P 1-UEG-FS/FS - Auxiliary contactor



2790428

<https://www.phoenixcontact.com/us/products/2790428>

## Drawings

Dimensional drawing

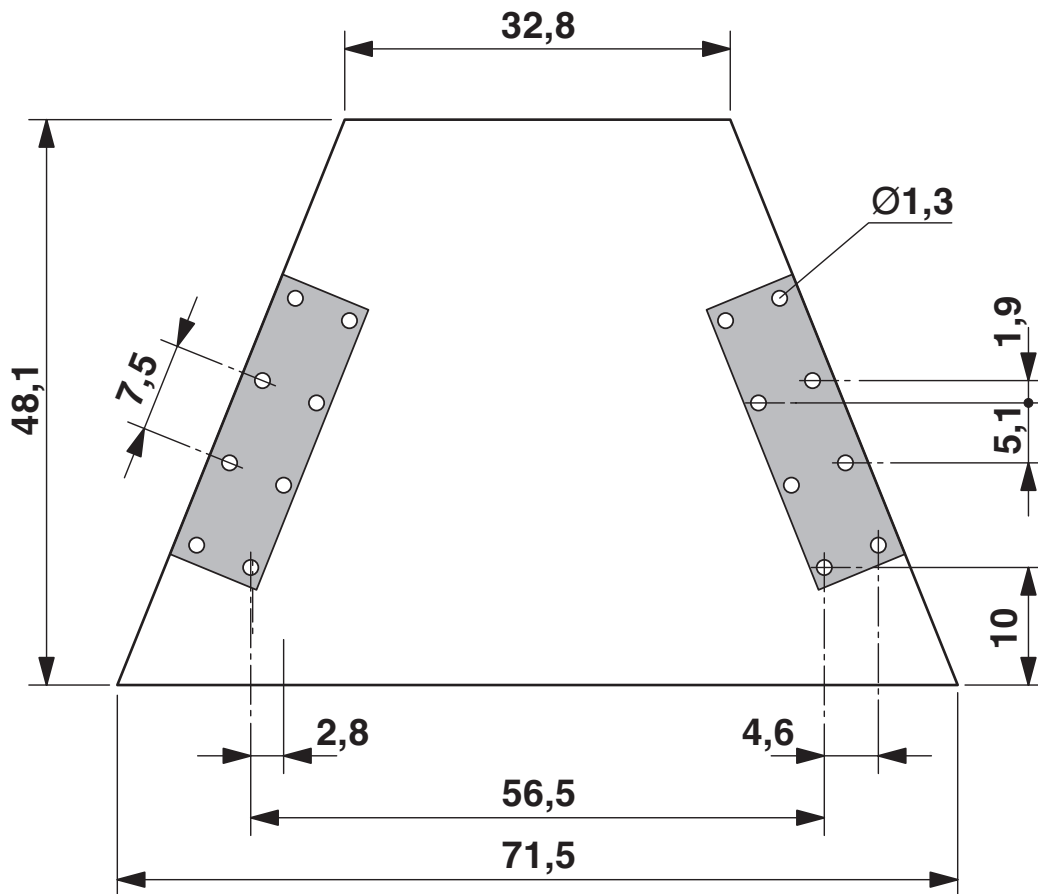

Soldering side of PCB layout  
1 = Overall component area

# P 1-UEG-FS/FS - Auxiliary contactor

2790428

<https://www.phoenixcontact.com/us/products/2790428>

Schematic diagram

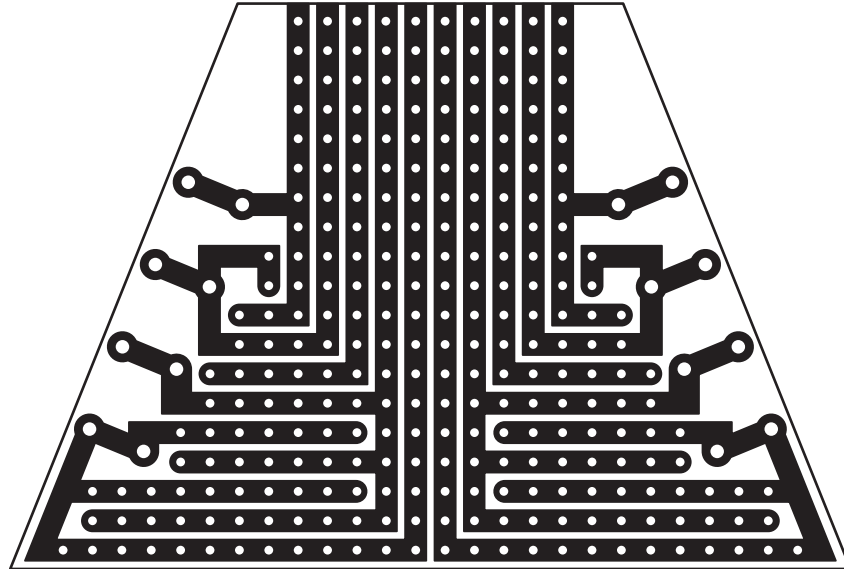

# P 1-UEG-FS/FS - Auxiliary contactor



2790428

<https://www.phoenixcontact.com/us/products/2790428>

## Environmental product compliance

### EU RoHS

Fulfills EU RoHS substance requirements	Yes, No exemptions
---	--------------------

### China RoHS

Environment friendly use period (EFUP)	EFUP-E
	No hazardous substances above the limits

### EU REACH SVHC

REACH candidate substance (CAS No.)	No substance above 0.1 wt%
-------------------------------------	----------------------------

Phoenix Contact 2026 © - all rights reserved  
<https://www.phoenixcontact.com>

Phoenix Contact USA  
586 Fulling Mill Road  
Middletown, PA 17057, United States  
(+717) 944-1300  
[info@phoenixcon.com](mailto:info@phoenixcon.com)