

UKK 3-MSTBVH-5,08 - Double-level terminal block



2770846

<https://www.phoenixcontact.com/us/products/2770846>

Please be informed that the data shown in this PDF document is generated from our online catalog. Please find the complete data in the user documentation. Our general terms of use for downloads are valid.



Double-level terminal block, nom. voltage: 250 V, nominal current: 12 A, number of connections: 4, number of positions: 1, connection method: Screw/plug-in connection, 1st and 2nd level connection left, cross section: 0.2 mm² - 4 mm², mounting type: NS 35/7,5, NS 35/15, NS 32, color: gray

Commercial data

| | |
|--------------------------------------|---------------|
| Item number | 2770846 |
| Packing unit | 50 pc |
| Minimum order quantity | 50 pc |
| Sales key | BE12 |
| Product key | BE1241 |
| GTIN | 4017918068073 |
| Weight per piece (including packing) | 9.514 g |
| Weight per piece (excluding packing) | 8.8 g |
| Customs tariff number | 85369010 |
| Country of origin | PL |

Technical data

Notes

| | |
|---------|--|
| General | Current and voltage are determined by the plug used. |
|---------|--|

Product properties

| | |
|-----------------------|----------------------------|
| Product type | Multi-level terminal block |
| Product family | UKK 3-MSTB |
| Number of positions | 1 |
| Pitch | 5.08 mm |
| Number of connections | 4 |
| Number of rows | 2 |
| Potentials | 2 |

Insulation characteristics

| | |
|----------------------|-----|
| Overvoltage category | III |
| Degree of pollution | 3 |

Electrical properties

| | |
|---|--------|
| Rated surge voltage | 4 kV |
| Maximum power dissipation for nominal condition | 0.77 W |

Connection data

| | |
|-------------------------|---------------------|
| Nominal cross section | 2.5 mm ² |
| Rated cross section AWG | 12 |

1st and 2nd level connection left

| | |
|---|--|
| Connection method | Screw/plug-in connection |
| Screw thread | M3 |
| Tightening torque | 0.5 ... 0.6 Nm |
| Stripping length | 8 mm |
| Internal cylindrical gage | A3 |
| Conductor cross-section rigid | 0.2 mm ² ... 4 mm ² |
| Cross section AWG | 24 ... 12 (converted acc. to IEC) |
| Conductor cross-section flexible | 0.2 mm ² ... 2.5 mm ² |
| Conductor cross-section, flexible [AWG] | 24 ... 14 (converted acc. to IEC) |
| Conductor cross-section flexible (ferrule without plastic sleeve) | 0.25 mm ² ... 2.5 mm ² |
| Flexible conductor cross-section (ferrule with plastic sleeve) | 0.25 mm ² ... 1.5 mm ² |
| 2 conductors with same cross section, rigid | 0.2 mm ² ... 1.5 mm ² |
| 2 conductors with same cross section, flexible | 0.2 mm ² ... 1 mm ² |
| 2 conductors with same cross section, flexible, with ferrule without plastic sleeve | 0.25 mm ² ... 0.5 mm ² |
| 2 conductors with the same cross section, flexible, with TWIN ferrule with plastic sleeve | 0.5 mm ² ... 1 mm ² |
| Nominal current | 12 A |

UKK 3-MSTBVH-5,08 - Double-level terminal block



2770846

<https://www.phoenixcontact.com/us/products/2770846>

| | |
|----------------------|---|
| Maximum load current | 12 A (with 4 mm ² conductor cross-section) |
| Nominal voltage | 250 V |

Dimensions

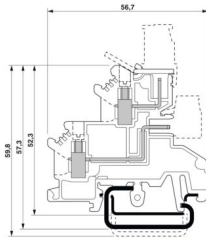
| | |
|---------------------|--|
| Dimensional drawing |  |
| Width | 5.08 mm |
| End cover width | 2.5 mm |
| Height | 50 mm |
| Depth on NS 35/7,5 | 52.5 mm |
| Pitch | 5.08 mm |

Material specifications

| | |
|--|-----------------|
| Color | gray (RAL 7042) |
| Flammability rating according to UL 94 | V2 |
| Insulating material group | I |
| Insulating material | PA |
| Contact surface | Tin Sn |
| Static insulating material application in cold | -40 °C |
| Relative insulation material temperature index (Elec., UL 746 B) | 125 °C |

Electrical tests

Surge voltage test

| | |
|--|-------------|
| Test voltage setpoint | 4.8 kV |
| Result | Test passed |
| Short-time withstand current 1 mm ² | 0.12 kA |
| Result | Test passed |

Power-frequency withstand voltage

| | |
|-----------------------|-------------|
| Test voltage setpoint | 1.5 kV |
| Result | Test passed |

Mechanical properties

Mechanical data

| | |
|-----------------|-----|
| Open side panel | Yes |
|-----------------|-----|

Mechanical tests

2770846

<https://www.phoenixcontact.com/us/products/2770846>

Attachment on the carrier

| | |
|-------------------------|-------------|
| DIN rail/fixing support | NS 32/NS 35 |
| Test force setpoint | 1 N |
| Result | Test passed |

Environmental and real-life conditions

Service life

| | |
|-----------------------------|-----|
| Insertion/withdrawal cycles | 100 |
|-----------------------------|-----|

Needle-flame test

| | |
|------------------|-------------|
| Time of exposure | 30 s |
| Result | Test passed |

Oscillation/broadband noise

| | |
|------------------------|--|
| Specification | DIN EN 50155 (VDE 0115-200):2022-06 |
| Spectrum | Long life test category 1, class B, body mounted |
| Frequency | $f_1 = 5 \text{ Hz}$ to $f_2 = 150 \text{ Hz}$ |
| ASD level | $0.964 \text{ (m/s}^2\text{)}/\text{Hz}$ |
| Acceleration | 0.58g |
| Test duration per axis | 5 h |
| Test directions | X-, Y- and Z-axis |
| Result | Test passed |

Shocks

| | |
|--------------------------------|-------------------------------------|
| Specification | DIN EN 50155 (VDE 0115-200):2022-06 |
| Pulse shape | Half-sine |
| Acceleration | 5g |
| Shock duration | 30 ms |
| Number of shocks per direction | 3 |
| Test directions | X-, Y- and Z-axis (pos. and neg.) |
| Result | Test passed |

Ambient conditions

| | |
|--|---|
| Ambient temperature (operation) | -60 °C (max. operating temperature see derating curve) |
| Ambient temperature (storage/transport) | -25 °C ... 60 °C (for a short time, not exceeding 24 h, -60 °C to +70 °C) |
| Ambient temperature (assembly) | -5 °C ... 70 °C |
| Ambient temperature (actuation) | -5 °C ... 70 °C |
| Permissible humidity (operation) | 20 % ... 90 % |
| Permissible humidity (storage/transport) | 30 % ... 70 % |

Mounting

| | |
|---------------|-----------|
| Mounting type | NS 35/7,5 |
| | NS 35/15 |
| | NS 32 |

UKK 3-MSTBVH-5,08 - Double-level terminal block

2770846

<https://www.phoenixcontact.com/us/products/2770846>

Drawings

Dimensional drawing

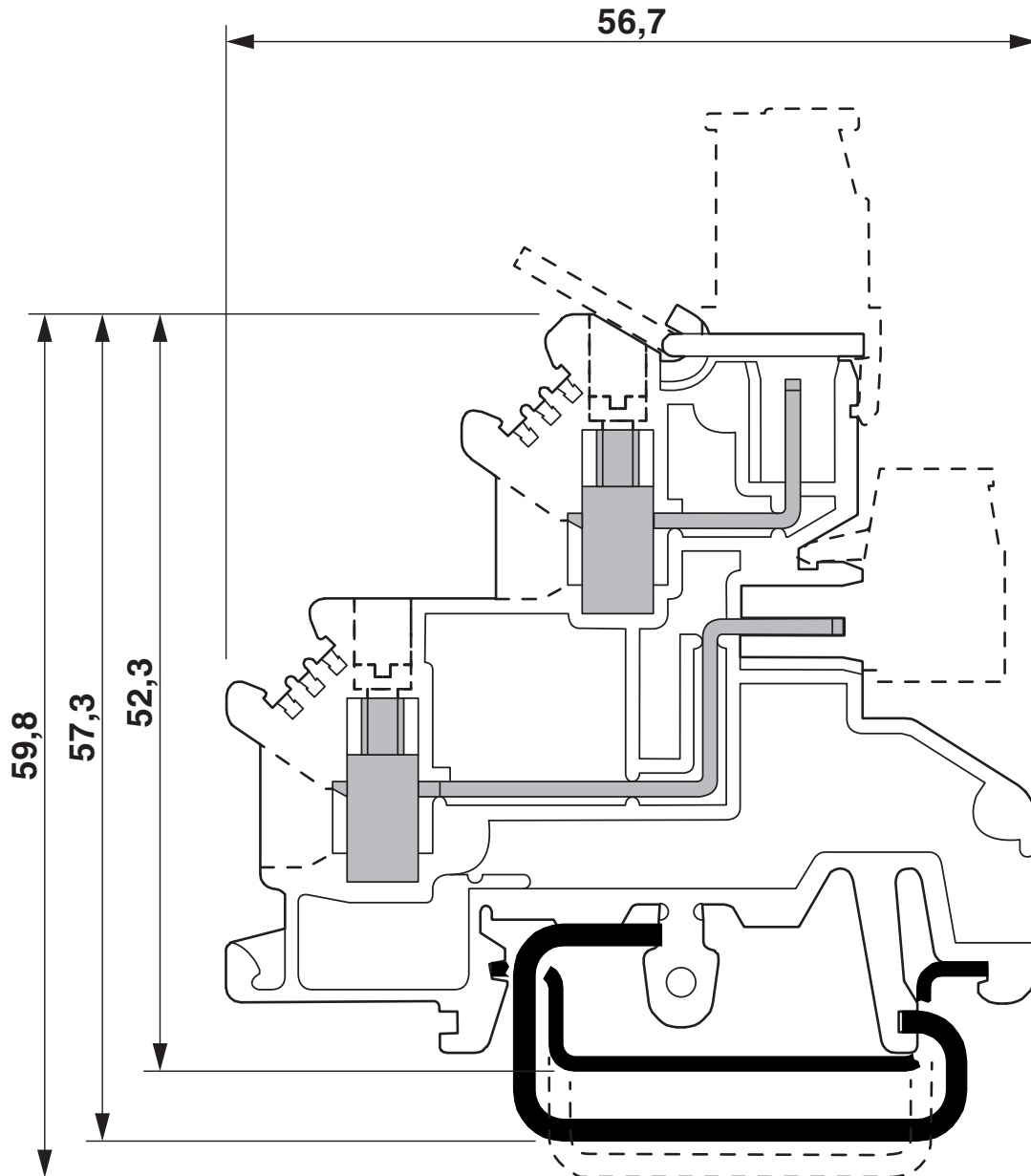

UKK 3-MSTBVH-5,08 - Double-level terminal block





2770846

<https://www.phoenixcontact.com/us/products/2770846>

Approvals

To download certificates, visit the product detail page: <https://www.phoenixcontact.com/us/products/2770846>

|  CSA Approval ID: 13631 | | | | |
|--|-----------------------|-----------------------|-------------------|-----------------------------|
| | Nominal voltage U_N | Nominal current I_N | Cross section AWG | Cross section mm^2 |
| keine | | | | |
| | 300 V | 10 A | 28 - 12 | - |

|  UL Recognized Approval ID: E60425 | | | | |
|---|-----------------------|-----------------------|-------------------|-----------------------------|
| | Nominal voltage U_N | Nominal current I_N | Cross section AWG | Cross section mm^2 |
| B | | | | |
| | 300 V | 10 A | 30 - 12 | - |
| C | | | | |
| | 150 V | 10 A | 30 - 12 | - |
| D | | | | |
| | 300 V | 10 A | 30 - 12 | - |

|  EAC Approval ID: KZ7500651131219505 | | | | |
|---|--|--|--|--|
|---|--|--|--|--|

UKK 3-MSTBVH-5,08 - Double-level terminal block



2770846

<https://www.phoenixcontact.com/us/products/2770846>

Classifications

ECLASS

| | |
|-------------|----------|
| ECLASS-13.0 | 27250102 |
| ECLASS-15.0 | 27250102 |

ETIM

| | |
|-----------|----------|
| ETIM 10.0 | EC000897 |
|-----------|----------|

UNSPSC

| | |
|-------------|----------|
| UNSPSC 21.0 | 39121400 |
|-------------|----------|

2770846

<https://www.phoenixcontact.com/us/products/2770846>

Environmental product compliance

EU RoHS

| | |
|---|------|
| Fulfills EU RoHS substance requirements | Yes |
| Exemption | 6(c) |

China RoHS

| | |
|--|---|
| Environment friendly use period (EFUP) | EFUP-50 |
| | An article-related China RoHS declaration table can be found in the download area for the respective article under "Manufacturer declaration". For all articles with EFUP-E, no China RoHS declaration table issued and required. |

EU REACH SVHC

| | |
|-------------------------------------|--------------------------------------|
| REACH candidate substance (CAS No.) | Lead(CAS: 7439-92-1) |
| SCIP | 00b8bb0e-cee4-497e-92d3-aba3452c6d4f |

EF3.1 Climate Change

| | |
|---------|---------------|
| CO2e kg | 0.034 kg CO2e |
|---------|---------------|

Phoenix Contact 2026 © - all rights reserved
<https://www.phoenixcontact.com>

Phoenix Contact USA
 586 Fulling Mill Road
 Middletown, PA 17057, United States
 (+717) 944-1300
info@phoenixcon.com