

UEGH 27,5-SMD - Electronics housing

2757128

<https://www.phoenixcontact.com/us/products/2757128>

Please be informed that the data shown in this PDF document is generated from our online catalog. Please find the complete data in the user documentation. Our general terms of use for downloads are valid.



Electronic housing, double level, fully equipped with 6 screw connections per side for one printed circuit board, for mounting of SMD components

The figure shows version UEGH
22,5

Commercial data

Item number	2757128
Packing unit	10 pc
Minimum order quantity	1 pc
Note	Made to order (non-returnable)
Sales key	AC11
Product key	ACHCCD
GTIN	4017918139520
Weight per piece (including packing)	79.88 g
Weight per piece (excluding packing)	66.608 g
Customs tariff number	85369010
Country of origin	DE

2757128

<https://www.phoenixcontact.com/us/products/2757128>

Technical data

Product properties

Product type	Complete housing
Housing type	Complete housing
Housing series	UEG
Product family	UEGH
Type	Connection system integrated, housing closed
Number of positions	12
Pitch	5 mm
Number of rows	2
Ventilation openings present	no
Pin layout	Linear pinning

Electrical properties

Nominal voltage U_N	500 V
Nominal current I_N	10 A

Connection data

Connection method	Screw connection
-------------------	------------------

Dimensions

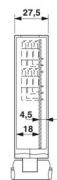
Dimensional drawing	
Width	27.5 mm
Installed height	106.7 mm
Height NS 35/7,5	106.7 mm
Depth	79 mm
Length	79 mm
Pitch	5 mm

Material specifications

Color (Housing)	green (RAL 6021)
Material Housing	PA
Flammability rating according to UL 94	V2

Environmental and real-life conditions

Ambient conditions

Ambient temperature (operation)	-40 °C ... 105 °C
---------------------------------	-------------------

UEGH 27,5-SMD - Electronics housing



2757128

<https://www.phoenixcontact.com/us/products/2757128>

Mounting

Mounting type	DIN rail mounting
Pin layout	Linear pinning

UEGH 27,5-SMD - Electronics housing

2757128

<https://www.phoenixcontact.com/us/products/2757128>



Drawings

Dimensional drawing

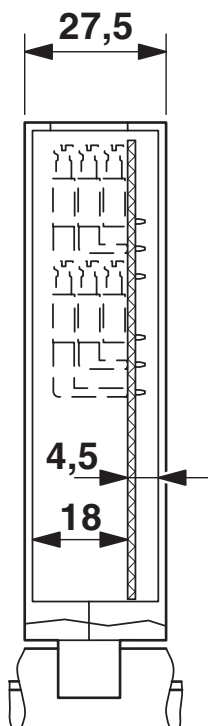

For 1 PCB, for SMD assembly of reverse side of PCB, 12 pos.

UEGH 27,5-SMD - Electronics housing

2757128

<https://www.phoenixcontact.com/us/products/2757128>



Dimensional drawing

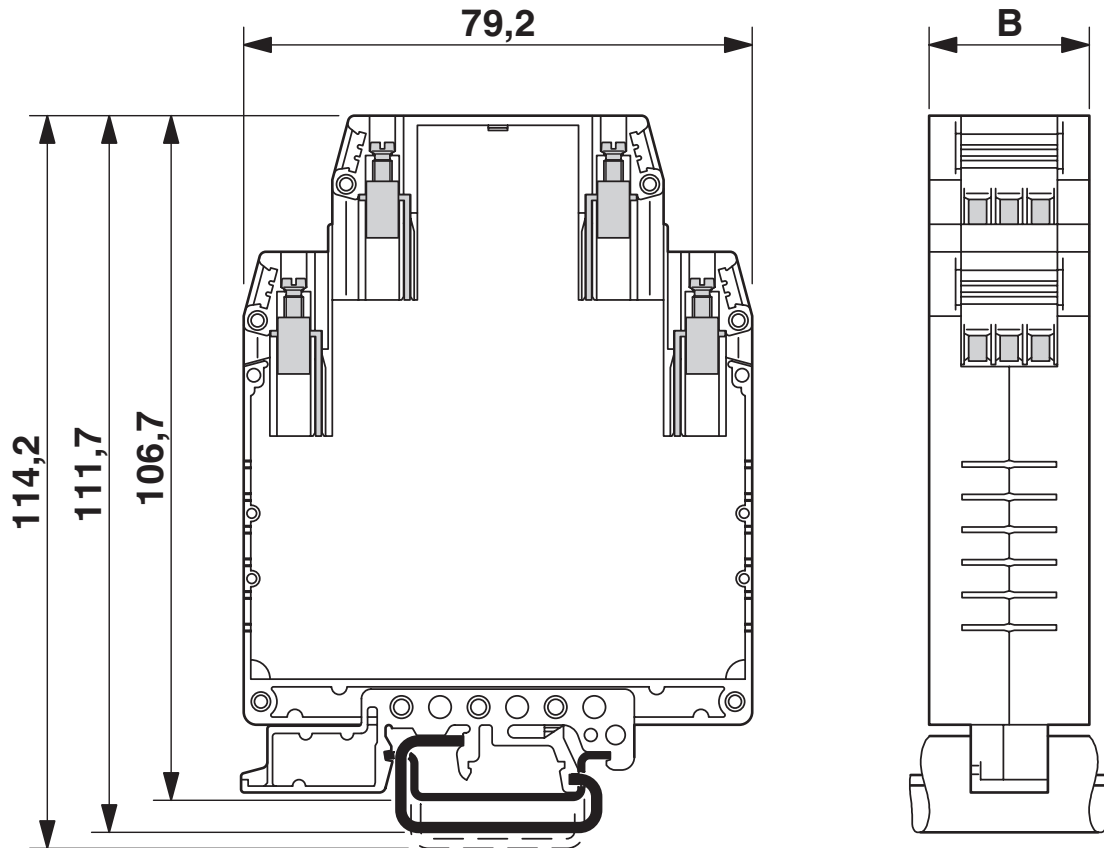

Dimensional drawing

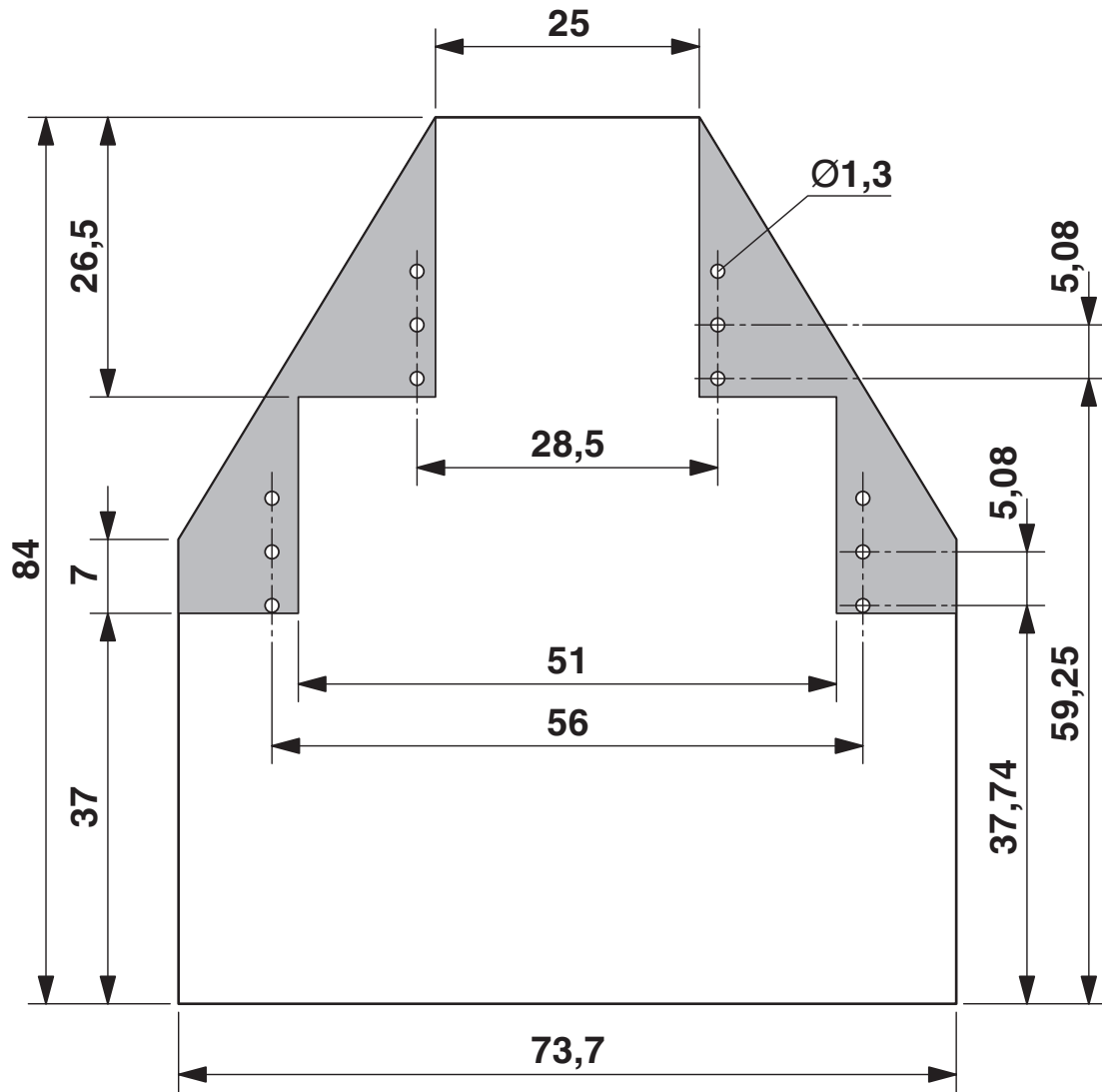

Schematic diagram

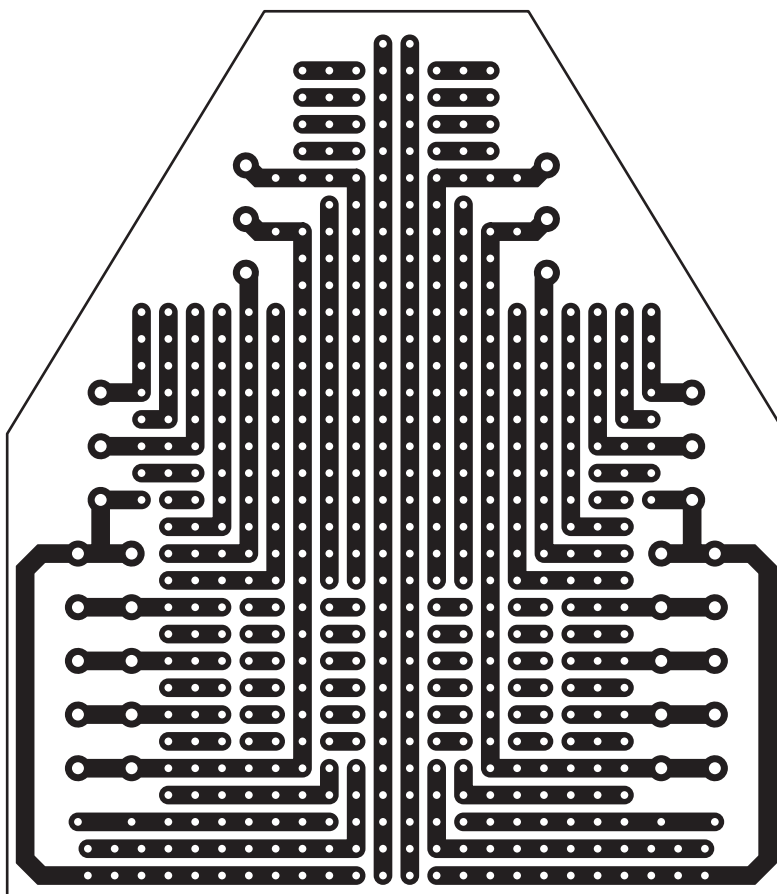

UEGH 27,5-SMD - Electronics housing



2757128

<https://www.phoenixcontact.com/us/products/2757128>

Approvals

To download certificates, visit the product detail page: <https://www.phoenixcontact.com/us/products/2757128>

 cULus Recognized Approval ID: E60425-19770427		Nominal voltage U_N	Nominal current I_N	Cross section AWG	Cross section mm^2
B		300 V	10 A	30 - 12	-
D		300 V	10 A	30 - 12	-

UEGH 27,5-SMD - Electronics housing



2757128

<https://www.phoenixcontact.com/us/products/2757128>

Classifications

ECLASS

ECLASS-13.0	27190101
ECLASS-15.0	27190101

ETIM

ETIM 10.0	EC001031
-----------	----------

UNSPSC

UNSPSC 21.0	31261500
-------------	----------

UEGH 27,5-SMD - Electronics housing



2757128

<https://www.phoenixcontact.com/us/products/2757128>

Environmental product compliance

EU RoHS

Fulfills EU RoHS substance requirements	Yes, No exemptions
---	--------------------

China RoHS

Environment friendly use period (EFUP)	EFUP-E
	No hazardous substances above the limits

EU REACH SVHC

REACH candidate substance (CAS No.)	No substance above 0.1 wt%
-------------------------------------	----------------------------

Phoenix Contact 2026 © - all rights reserved
<https://www.phoenixcontact.com>

Phoenix Contact USA
586 Fulling Mill Road
Middletown, PA 17057, United States
(+717) 944-1300
info@phoenixcon.com