

# IB ST 24 BAI 8/I - I/O module

2721028

<https://www.phoenixcontact.com/us/products/2721028>

Please be informed that the data shown in this PDF document is generated from our online catalog. Please find the complete data in the user documentation. Our general terms of use for downloads are valid.



INTERBUS-ST analog input module, 8 inputs, 0 to 20 mA, 4 to 20 mA, 0 to 40 mA, 0 to 60 mA, IP20 protection, consisting of: terminal part with screw connection and module electronics

The figure shows version IB ST 24 BAI 8/U

## Product description

INTERBUS ST standard analog input modules

The wide range of INTERBUS analog input modules makes it possible to choose the ideal product for a variety of applications.

All commercially available analog standard sensors with voltage or current signals can be connected. Particular features of the INTERBUS analog input modules are:

- High accuracy of measurement
- Extremely rapid acquisition of measurement values
- Very good interference and common mode suppression
- A constant voltage source for the connection of passive sensors

Moreover, a host of measures guarantee a high standard of operational reliability, even under extreme industrial environmental conditions. In addition to integrated safety systems, such as:

- Watchdog monitoring of the processor, or
- Monitoring the supply voltage, in particular, comprehensive EMC measures, for example, a new shielding concept

There is a separate shield connection option for each input, without extra external wiring necessary. The connection to protective earth ground is created automatically when the module is snapped onto the DIN rail.

All the typical advantages of INTERBUS ST handling, such as multi-wire connection method and plug-in electronics are available.

## Your advantages

- 8 analog current inputs
- Connection of sensors in 2-conductor technology
- Temperature measurement modules
- Standard signal types (voltage and current)

## Commercial data

Item number	2721028
Packing unit	1 pc
Note	Made to order (non-returnable)
Sales key	DR03
Product key	DRI341
GTIN	4017918132309
Weight per piece (including packing)	655.7 g
Weight per piece (excluding packing)	600 g
Customs tariff number	85389091

# IB ST 24 BAI 8/I - I/O module

2721028

<https://www.phoenixcontact.com/us/products/2721028>



Country of origin	DE
-------------------	----

# IB ST 24 BAI 8/I - I/O module



2721028

<https://www.phoenixcontact.com/us/products/2721028>

## Technical data

### Dimensions

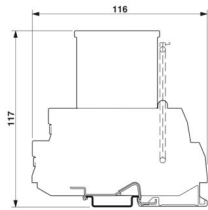
Dimensional drawing	
Width	118 mm
Height	117 mm
Length	116 mm

### Notes

#### Utilization restriction

EMC note	EMC: class A product, see manufacturer's declaration in the download area
----------	---

### Interfaces

#### ST local bus

Connection method	ST local bus connector
Transmission speed	500 kbps
Transmission physics	Copper
Transmission length	116 mm

### Product properties

Product type	I/O component
Product family	Smart Terminal ST
Type	modular INTERBUS Smart Terminal
No. of channels	8

### Electrical properties

Maximum power dissipation for nominal condition	1.632 W
Test section	Bus/Inputs 500 V AC 50 Hz 1 min Supply voltage/inputs 500 V AC 50 Hz 1 min Supply voltage/Ground conductor 500 V AC 50 Hz 1 min I/O voltage/Ground conductor 500 V AC 50 Hz 1 min

#### Supply

Communications power $U_L$	9 V DC (from the ST local bus)
I/O voltage	$\pm 24$ V DC 5 % (ripple)
I/O voltage range	18.5 V DC ... 30.2 V DC

# IB ST 24 BAI 8/I - I/O module



2721028

<https://www.phoenixcontact.com/us/products/2721028>

Max. current consumption	160 mA (without passive sensors)
Typical current consumption	68 mA (without passive sensors)

## Connection data

### Connection technology

Connection name	Terminal block
-----------------	----------------

### Terminal block

Connection method	Screw connection
Conductor cross-section, rigid	0.2 mm <sup>2</sup> ... 2.5 mm <sup>2</sup>
Conductor cross-section, flexible	0.2 mm <sup>2</sup> ... 2.5 mm <sup>2</sup>
Conductor cross-section AWG	24 ... 12
Stripping length	8 mm

## Environmental and real-life conditions

### Ambient conditions

Degree of protection	IP20
----------------------	------

## Mounting

Mounting type	DIN rail mounting
---------------	-------------------

# IB ST 24 BAI 8/I - I/O module

2721028

<https://www.phoenixcontact.com/us/products/2721028>



## Drawings

Dimensional drawing

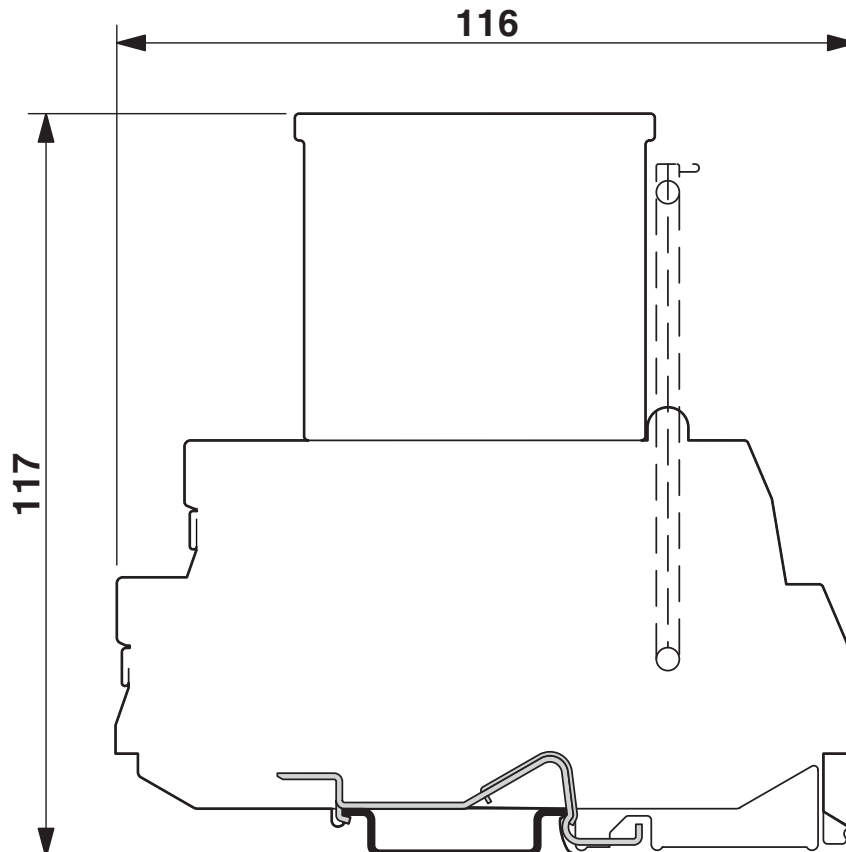

Connection diagram

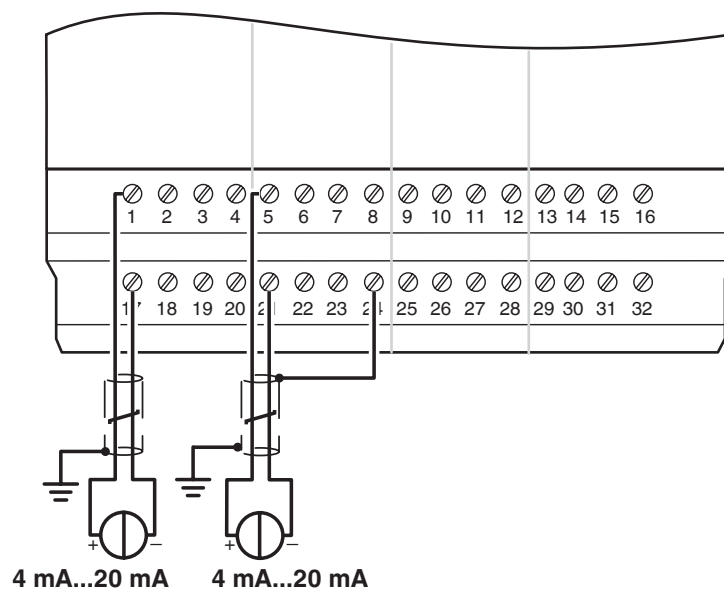

# IB ST 24 BAI 8/I - I/O module



2721028

<https://www.phoenixcontact.com/us/products/2721028>

## Environmental product compliance

### China RoHS

Environment friendly use period (EFUP)	EFUP-E
	No hazardous substances above the limits

### EU REACH SVHC

REACH candidate substance (CAS No.)	No substance above 0.1 wt%
-------------------------------------	----------------------------

Phoenix Contact 2026 © - all rights reserved  
<https://www.phoenixcontact.com>

Phoenix Contact USA  
586 Fulling Mill Road  
Middletown, PA 17057, United States  
(+717) 944-1300  
[info@phoenixcon.com](mailto:info@phoenixcon.com)