

# FL NAT 2208 - Industrial Ethernet Switch



2702882

<https://www.phoenixcontact.com/us/products/2702882>

Please be informed that the data shown in this PDF document is generated from our online catalog. Please find the complete data in the user documentation. Our general terms of use for downloads are valid.



Managed NAT Switch 2000 series, 8 RJ45 ports 10/100 Mbps, degree of protection: IP20, Ambient temperature (operation): -40 °C ... 70 °C, Supply voltage range: 9 V DC ... 57 V DC, PROFINET Conformance Class B, 1:1-NAT, Virtual NAT, IP-Masquerading, Development process certified in accordance with IEC 62443-4-1, Product certified in accordance with IEC 62443-4-2

## Your advantages

- 1:1 NAT, virtual NAT, IP masquerading, port forwarding
- Flexible distribution into several LAN and WAN areas
- Ambient temperature -40 °C ... 70 °C
- MRP (client and manager)
- VLANs
- RSTP
- DHCP client, DHCP server (pool-based and port-based), DHCP option 82
- Slim design
- Web-based management, SNMP
- Configuration memory
- Easy and fast startup and commissioning with the FL NETWORK MANAGER software
- Suitable for PROFINET and EtherNet/IP™ networks

## Commercial data

Item number	2702882
Packing unit	1 pc
Minimum order quantity	1 pc
Sales key	DN17
Product key	DNN131
GTIN	4055626384825
Weight per piece (including packing)	393 g
Weight per piece (excluding packing)	230 g
Customs tariff number	85176200
Country of origin	DE

# FL NAT 2208 - Industrial Ethernet Switch



2702882

<https://www.phoenixcontact.com/us/products/2702882>

## Technical data

### Dimensions

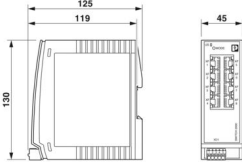
Dimensional drawing	
Width	45 mm
Height	130 mm
Depth	115 mm

### Notes

General	Support by phone or on-site (fee is charged)
Note on application	
Note on application	Only for industrial use

### Material specifications

Housing material	Polycarbonate fiber reinforced
------------------	--------------------------------

### Mounting

Mounting type	DIN rail mounting
---------------	-------------------

### Interfaces

#### Ethernet (RJ45)

Connection method	RJ45
Note on the connection method	Auto negotiation and autocrossing
Transmission speed	10/100 Mbps
Transmission physics	Copper
Transmission length	100 m (per segment)
Signal LEDs	Data receive, link status
No. of channels	8 (RJ45 ports)

### Output data

#### Digital:

Output name	Alarm output
-------------	--------------

### Product properties

Product type	Switch
Product family	Managed NAT Switch 2000
Type	Book type

# FL NAT 2208 - Industrial Ethernet Switch



2702882

<https://www.phoenixcontact.com/us/products/2702882>

MTTF	494.02 Years (SN 29500 standard, temperature 25°C, operating cycle 21%)
	235.18 Years (SN 29500 standard, temperature 40°C, operating cycle 34.25%)
	29.73 Years (SN 29500 standard, temperature 70°C, operating cycle 100%)
Special properties	1:1-NAT, Virtual NAT, IP-Masquerading
	Development process certified in accordance with IEC 62443-4-1
	Product certified in accordance with IEC 62443-4-2
Signal delay	≥ 6.5 μs (Store and Forward mode, 10/100 Mbps, depending on the frame size)

## Insulation characteristics

Protection class	III (VDE 0106)
Degree of pollution	2

## Switch functions

Diagnostic functions	RMON History
	LLDP (Link Layer Discovery Protocol)
	SNMP-Traps
	N:1-Portmirroring
	ACD (Address Conflict Detection)
	SysLog
	CRC-Surveillance
Basic functions	Store-and-forward switch, complies with IEEE 802.3
Signal contact control voltage	typ. 24 V DC
NAT functions	1:1-NAT
	Virtual-NAT
	IP-Masquerading
	Port forwarding
PROFINET conformance class	Conformance Class B
PROFINET device function	PROFINET device
Filter functions	Quality of Service (8 priority classes)
	Class of Service
	DiffServ/DSCP
	Port-Priorisierung
	VLAN (up to 32 VLANs)
	IGMP Snooping/Querier (v1/v2)
	Auto-Query-Port
	Extended Multicast Filtering
IP parameterization	DHCP client
	DHCP Option 82 (Relay Agent)
	DHCP server (pool-based, port-based)
	BootP
	DCP (Discovery and Configuration Protocol)
MAC address table	8k

Management	Web-based management (HTTP/HTTPS)
	Role-based user management (LDAP, RADIUS)
	SNMPv1/v2/v3
	Command Line Interface (Telnet, SSH)
Redundancy	MRP (Media Redundancy Protocol)
	RSTP (Rapid Spanning Tree Protocol)
	FRD (Fast Ring Detection)
	Large Tree Support
	LACP (Link Aggregation Control Protocol)
	PROFINET S2 system redundancy
Status and diagnostic indicators	LEDs: US1, US2 (power supply), Fail (alarm contact), 2 LEDs per Ethernet port (Link/Activity and Speed)
Time synchronization	SNTP (Simple Network Time Protocol)

#### Security functions

Port security	MAC-based, RADIUS (IEEE 802.1X), MAC Authentication Bypass
Basic functions	Store-and-forward switch, complies with IEEE 802.3

#### Electrical properties

Current consumption	190 mA
Local diagnostics	US1/2 Supply voltage US1, US2 Green LED
	FAIL Div. LED red
	LINK Link status Green LED
Maximum power dissipation for nominal condition	4.95 W (At $U_S = 9$ V DC and 70°C ambient temperature)
Test section	24 V supply / functional ground 500 V DC 1 min
	Ethernet interface/all other potentials 2.25 kV DC
Transmission medium	Copper

#### Supply

Supply voltage (DC)	24 V DC (redundant)
Supply voltage range	9 V DC ... 57 V DC
Power supply connection	via COMBICON, max. conductor cross-section 1.5 mm <sup>2</sup>
Residual ripple	3.6 V <sub>pp</sub> (within the permitted voltage range)
Max. current consumption	1.3 A ( $U_S = \text{Min}$ , $T_{\text{amb}} = \text{Max}$ , $DO_1 = \text{Max}$ )
Typical current consumption	185 mA (at $U_S = 24$ V DC and 25 °C ambient temperature)
Current consumption	190 mA

#### Function

Signal contact control voltage	typ. 24 V DC
--------------------------------	--------------

#### Connection data

Connection method	Screw connection
Note on the connection method	Use only copper connecting cables providing the permitted temperature range (-40 °C ... 75 °C)
pluggable	yes

2702882

<https://www.phoenixcontact.com/us/products/2702882>

Conductor cross-section, rigid	0.08 mm <sup>2</sup> ... 1.5 mm <sup>2</sup>
Conductor cross-section, flexible	0.08 mm <sup>2</sup> ... 1.5 mm <sup>2</sup>
Conductor cross-section AWG	28 ... 16
Stripping length	7 mm

## Environmental and real-life conditions

### Ambient conditions

Degree of protection	IP20
Ambient temperature (operation)	-40 °C ... 70 °C
Ambient temperature (storage/transport)	-40 °C ... 85 °C
Permissible humidity (operation)	10 % ... 95 % (non-condensing)
Permissible humidity (storage/transport)	10 % ... 95 % (non-condensing)
Shock (operation)	30g (EN 60068-2-27)
Vibration (operation)	in acc. with IEC 60068-2-6: 5g, 150 Hz
Air pressure (operation)	80 kPa ... 110 kPa up to 2000 m above mean sea level (Without derating)
Air pressure (storage/transport)	79 kPa ... 108 kPa up to 2000 m above mean sea level (Without derating)

## Standards and regulations

Free from substances that could impair the application of coating	Yes
---	-----

## Approvals

### ATEX

Identification	⊕ II 3 G Ex ec IIC T4 Gc
Certificate	DEMKO 16 ATEX 1709X

### IECEX

Identification	Ex ec IIC T4 Gc
Certificate	IECEX ULD 16.0018 X

### UL, USA/Canada

Identification	cULus
----------------	-------

### UL Ex, USA / Canada

Identification	Class I, Division 2, Groups A, B, C, and D, T4
	Class I, Zone 2, AEx ec IIC T4
	Ex ec IIC T4 Gc X
Certificate	E366272
Note	UL 60079-0 Ed. 6 / UL 60079-7 Ed. 5, CSA 22.2 No. 60079-0 Ed. 3 / CSA C22.2 No. 60079-7 Ed. 2

### EAC Ex

Identification	2Ex e IIC T4 Gc X
Certificate	RU C-DE.HB49.B.00118/21

# FL NAT 2208 - Industrial Ethernet Switch



2702882

<https://www.phoenixcontact.com/us/products/2702882>

The following continue to apply for EAC Ex:

Identification	Install the device in a suitable, approved housing with at least IP66 protection.
	The housing/control cabinet must be equipped with a warning sign prohibiting opening in the potentially explosive area.
	The operation of devices is permitted if all optical ports are connected or sealed with the supplied filler plugs.

CCC / China-Ex

Identification	Ex ec IIC T4 Gc
Certificate	2022122310115629

Corrosive gas test

Identification	ISA S71.04.2013 G3 Harsh Group A
----------------	----------------------------------

UKCA Ex (UKEX)

Identification	Ⓜ II 3 G Ex ec IIC T4 Gc
Certificate	PxCIMA22UKEX2702910X

Shipbuilding data

Temperature	B
Humidity	B
Vibration	A
EMC	B
Enclosure	Required protection according to the Rules shall be provided upon installation on board

EMC data

Electromagnetic compatibility	Conformance with EMC Directive 2014/30/EU
Conformance with EMC directives	EN 61000-6-2 EN 61000-4-2 (ESD) Criterion B
	EN 61000-6-2 EN 61000-4-3 (electromagnetic fields) Criterion A
	EN 61000-6-2 EN 61000-4-4 (EFT burst) Criterion A
	EN 61000-6-2 EN 61000-4-5 (surge) Criterion B
	EN 61000-6-2 EN 61000-4-6 (line noise immunity) Criterion A
	EN 61000-6-2 EN 61000-6-4 (interference) Class A
Noise immunity	EN 61000-6-2

Noise emission

Standards/regulations	EN 61000-6-4
-----------------------	--------------

System properties

Functionality

Basic functions	Store-and-forward switch, complies with IEEE 802.3
-----------------	--

Signaling

Status display	LEDs: US1, US2 (power supply), Fail (alarm contact), 2 LEDs per
----------------	---

# FL NAT 2208 - Industrial Ethernet Switch



2702882

<https://www.phoenixcontact.com/us/products/2702882>

---

Ethernet port (Link/Activity and Speed)

# FL NAT 2208 - Industrial Ethernet Switch

2702882

<https://www.phoenixcontact.com/us/products/2702882>



## Drawings

Dimensional drawing

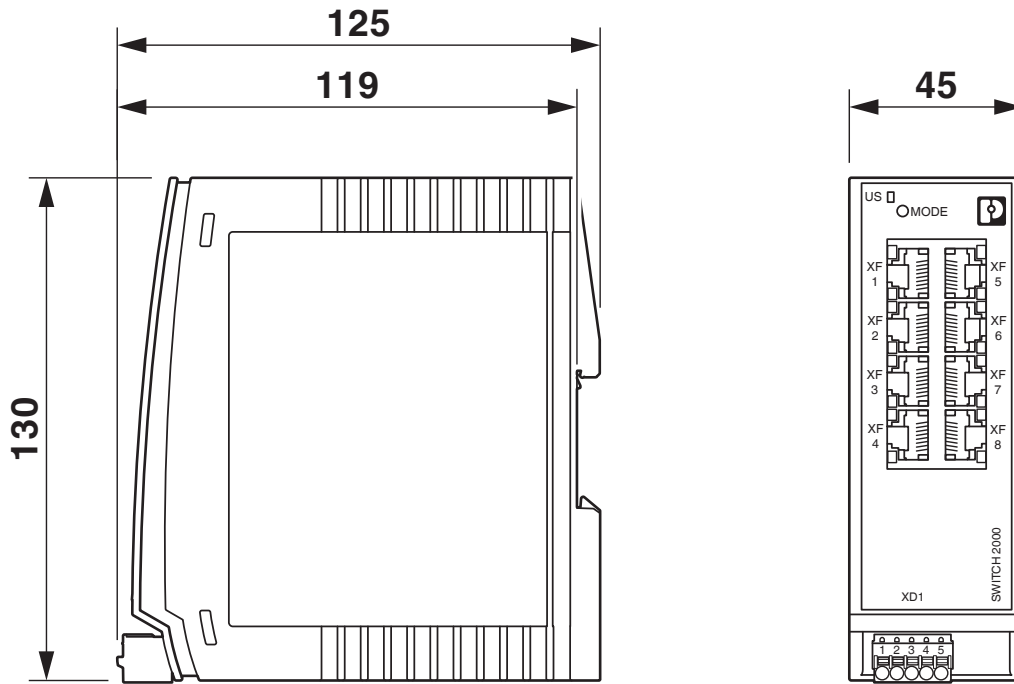

2702882

<https://www.phoenixcontact.com/us/products/2702882>

## Approvals

To download certificates, visit the product detail page: <https://www.phoenixcontact.com/us/products/2702882>



**DNV GL**

Approval ID: TAA00000YV



**LR**

Approval ID: LR22250919TA



**NK**

Approval ID: TA24215M



**BV**

Approval ID: 48146\_B1 BV

**BSH**

Approval ID: Nr. 966



**RINA**

Approval ID: ELE014724XG001

**ABS**

Approval ID: 21\_2066186\_1\_PDA



**cULus Listed**

Approval ID: E238705

**Cybersecurity Certificate**

Approval ID: 968 CSP 1043.00 25



**IECEX**

Approval ID: IECEX ULD 16.0018X



**ATEX**

Approval ID: DEMKO 16 ATEX 1709X

# FL NAT 2208 - Industrial Ethernet Switch



2702882

<https://www.phoenixcontact.com/us/products/2702882>



**CCC**

Approval ID: 2022122310115629



**cULus Listed**

Approval ID: E366272

# FL NAT 2208 - Industrial Ethernet Switch



2702882

<https://www.phoenixcontact.com/us/products/2702882>

## Classifications

### ECLASS

ECLASS-13.0	19170401
ECLASS-15.0	19170401

### ETIM

ETIM 10.0	EC000734
-----------	----------

### UNSPSC

UNSPSC 21.0	43222600
-------------	----------

2702882

<https://www.phoenixcontact.com/us/products/2702882>

## Environmental product compliance

### EU RoHS

Fulfills EU RoHS substance requirements	Yes
Exemption	7(a), 7(c)-I

### China RoHS

Environment friendly use period (EFUP)	EFUP-50
	An article-related China RoHS declaration table can be found in the download area for the respective article under "Manufacturer declaration". For all articles with EFUP-E, no China RoHS declaration table issued and required.

### EU REACH SVHC

REACH candidate substance (CAS No.)	Lead(CAS: 7439-92-1)
SCIP	db0dfb23-49f3-4d28-9df1-abe95d18712b

### EF3.1 Climate Change

CO2e kg	8.949 kg CO2e
---------	---------------

Phoenix Contact 2026 © - all rights reserved  
<https://www.phoenixcontact.com>

Phoenix Contact USA  
586 Fulling Mill Road  
Middletown, PA 17057, United States  
(+717) 944-1300  
[info@phoenixcon.com](mailto:info@phoenixcon.com)