

IB IL AI 4/U/0-10-ECO - Analog module



2702496

<https://www.phoenixcontact.com/us/products/2702496>

Please be informed that the data shown in this PDF document is generated from our online catalog. Please find the complete data in the user documentation. Our general terms of use for downloads are valid.

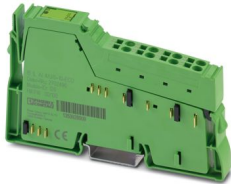

Inline, Analog input terminal, Analog inputs: 4, 0 V ... 10 V, connection technology: 2-conductor, transmission speed in the local bus: 500 kbps, degree of protection: IP20, including Inline connector

Product description

The terminal is designed for use within an Inline station. It is used to acquire analog voltage signals. The measured values are depicted in standardized representation format. Inline ECO terminals are approved for the temperature range from 0°C to +55°C. The electronics base and Inline connector are supplied as standard.

Your advantages

- 4 analog input channels
- Connection of sensors in 2-conductor technology
- Voltage range: 0 V ... 10 V
- Data format: standardized representation
- Resolution: 12 bits
- Diagnostic indicator

Commercial data

Item number	2702496
Packing unit	1 pc
Minimum order quantity	1 pc
Sales key	DR01
Product key	DRI141
GTIN	4055626205021
Weight per piece (including packing)	74.3 g
Weight per piece (excluding packing)	69 g
Customs tariff number	85389099
Country of origin	DE

IB IL AI 4/U/0-10-ECO - Analog module

2702496

<https://www.phoenixcontact.com/us/products/2702496>

Technical data

Dimensions

Dimensional drawing	
Width	12.2 mm
Height	119.8 mm
Depth	71.5 mm

Notes

Note on application

Note on application	Only for industrial use
---------------------	-------------------------

Interfaces

Inline local bus

Number of interfaces	2
Connection method	Inline data jumper
Transmission speed	500 kbps

System properties

Module

ID code (dec.)	126
ID code (hex)	7E
Length code (hex)	04
Length code (dec)	04
Process data channel	64 bit
Input address area	8 Byte
Output address area	0 Byte
Register length	64 bit
Required parameter data	1 Byte
Required configuration data	4 Byte

Input data

Analog: General

Input name	Analog inputs
Description of the input	Single-ended inputs, voltage
Number of inputs	4

IB IL AI 4/U/0-10-ECO - Analog module



2702496

<https://www.phoenixcontact.com/us/products/2702496>

Connection method	Inline connector
Connection technology	2-conductor
Note regarding the connection technology	shielded, twisted pair
Voltage input signal	0 V ... 10 V
Input resistance of voltage input	115 kΩ
A/D converter resolution	12 bit
Data formats	Standardized representation
Measured value representation	16 bits
Protective circuit	Overload protection; ±30 V DC, maximum Transient protection; Suppressor diode

Product properties

Product type	I/O component
Product family	Inline
Type	modular
Installation location	Control cabinet
Scope of supply	including Inline connector
Diagnostics messages	Failure of the internal I/O supply I/O error message sent to the bus coupler Checksum error I/O error message sent to the bus coupler

Electrical properties

Maximum power dissipation for nominal condition	0.9 W
---	-------

Potentials: Communications power (U_L)

Supply voltage	7.5 V DC (via voltage jumper)
Current draw	max. 70 mA typ. 60 mA

Potentials: Supply of analog modules (U_{ANA})

Supply voltage	24 V DC (via voltage jumper)
Supply voltage range	19.2 V DC ... 30 V DC (including all tolerances, including ripple)
Current draw	max. 20 mA typ. 15 mA

Electrical isolation/isolation of the voltage ranges

Test voltage: Bus logic (local bus, communications power)	500 V AC, 50 Hz, 1 min
Test voltage: Analog I/O	500 V AC, 50 Hz, 1 min
Test voltage: Functional ground	500 V AC, 50 Hz, 1 min

Connection data

Connection technology

Connection name	Inline connector
-----------------	------------------

Inline connector

Connection method	Spring-cage connection
-------------------	------------------------

IB IL AI 4/U/0-10-ECO - Analog module



2702496

<https://www.phoenixcontact.com/us/products/2702496>

Conductor cross-section, rigid	0.08 mm ² ... 1.5 mm ²
Conductor cross-section, flexible	0.08 mm ² ... 1.5 mm ²
Conductor cross-section AWG	28 ... 16
Stripping length	8 mm

Environmental and real-life conditions

Ambient conditions

Ambient temperature (operation)	0 °C ... 55 °C
Degree of protection	IP20
Air pressure (operation)	70 kPa ... 106 kPa (up to 3000 m above sea level)
Air pressure (storage/transport)	70 kPa ... 106 kPa (up to 3000 m above sea level)
Ambient temperature (storage/transport)	-25 °C ... 85 °C
Permissible humidity (operation)	10 % ... 95 % (according to DIN EN 61131-2)
Permissible humidity (storage/transport)	10 % ... 95 % (according to DIN EN 61131-2)

Standards and regulations

Protection class	III (IEC 61140, EN 61140, VDE 0140-1)
------------------	---------------------------------------

Mounting

Mounting type	DIN rail mounting
---------------	-------------------

IB IL AI 4/U/0-10-ECO - Analog module

2702496

<https://www.phoenixcontact.com/us/products/2702496>

Drawings

Dimensional drawing



Connection diagram

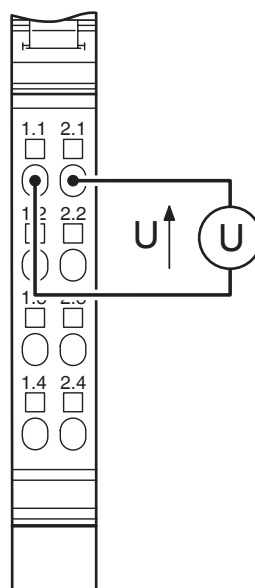

Connecting the sensors

IB IL AI 4/U/0-10-ECO - Analog module

2702496

<https://www.phoenixcontact.com/us/products/2702496>



Block diagram

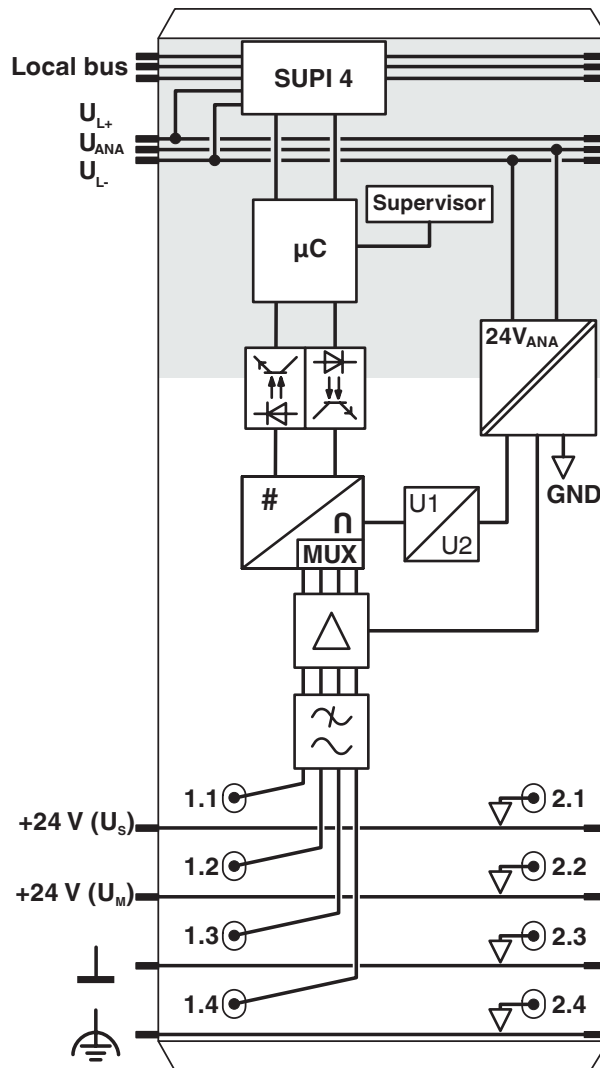

IB IL AI 4/U/0-10-ECO - Analog module



2702496

<https://www.phoenixcontact.com/us/products/2702496>

Approvals

To download certificates, visit the product detail page: <https://www.phoenixcontact.com/us/products/2702496>



cULus Listed

Approval ID: E238705



cULus Listed

Approval ID: E238705

IB IL AI 4/U/0-10-ECO - Analog module



2702496

<https://www.phoenixcontact.com/us/products/2702496>

Classifications

ECLASS

ECLASS-13.0	27242601
ECLASS-15.0	27242601

ETIM

ETIM 10.0	EC001596
-----------	----------

UNSPSC

UNSPSC 21.0	32151600
-------------	----------

2702496

<https://www.phoenixcontact.com/us/products/2702496>

Environmental product compliance

EU RoHS

Fulfills EU RoHS substance requirements	Yes
Exemption	7(a), 7(c)-I, 7(c)-II

China RoHS

Environment friendly use period (EFUP)	EFUP-50
	An article-related China RoHS declaration table can be found in the download area for the respective article under "Manufacturer declaration". For all articles with EFUP-E, no China RoHS declaration table issued and required.

EU REACH SVHC

REACH candidate substance (CAS No.)	Lead(CAS: 7439-92-1)
SCIP	977f11f4-92a9-45e5-801a-89f24a808905

Phoenix Contact 2026 © - all rights reserved

<https://www.phoenixcontact.com>

Phoenix Contact USA
586 Fulling Mill Road
Middletown, PA 17057, United States
(+717) 944-1300
info@phoenixcon.com