

TC ETH EXTENDER S19 - Modem



2702077

<https://www.phoenixcontact.com/us/products/2702077>

Please be informed that the data shown in this PDF document is generated from our online catalog. Please find the complete data in the user documentation. Our general terms of use for downloads are valid.

19" Ethernet communication unit for networking systems and stations via SHDSL technology. Data rates of up to 30 Mbps, distances of up to 20 km on in-house copper cables via line, star, and ring structures. Diagnostics via LEDs or software.



Commercial data

Item number	2702077
Packing unit	1 pc
Minimum order quantity	1 pc
Product key	DNC444
GTIN	4046356945516
Weight per piece (including packing)	10.9 kg
Weight per piece (excluding packing)	10.9 kg
Country of origin	DE

Technical data

Notes

Note on application

Note on application	Only for industrial use
---------------------	-------------------------

Product properties

Product type	Modem
MTTF	34 Years (SN 29500 standard, temperature 25°C, operating cycle 21%)
	26 Years (SN 29500 standard, temperature 40°C, operating cycle 34.25%)
	16 Years (SN 29500 standard, temperature 40°C, operating cycle 100%)

Electrical properties

Electrical isolation	VCC // Ethernet // DSL (A) // DSL (B) // FE
Maximum power dissipation for nominal condition	69 W
Mains type	Permanent line
Test voltage data interface/power supply	1.5 kV _{rms} (50 Hz, 1 min.)

Supply

Supply voltage range	100 V AC ... 240 V AC
Nominal supply voltage	230 V AC (50 Hz ... 60 Hz)
Typical current consumption	< 300 mA (220 V AC)

Function

Management	Plug and Play, diagnostics via PSI-CONF software or web-based management (only with managed Ethernet extenders)
------------	---

Interfaces

Signal	Ethernet
--------	----------

Data: Ethernet interface, 10/100Base-T(X) in accordance with IEEE 802.3

Serial transmission speed	10/100 Mbps, auto negotiation
Connection method	RJ45 jack, shielded
No. of channels	4
Transmission length	< 100 m (shielded twisted pair)
Protocols supported	Transparent protocol for IPv4 and IPv6

Data: SHDSL interface according to ITU-T G.991.2.bis

Serial transmission speed	4-wire operation: 64 kbps ... 30 Mbps
	2-wire operation: 32 kbps ... 15.3 Mbps
Connection method	Socket M8
No. of channels	12 (2-wire operation)
Transmission length	< 20 km (Depending on data rate and cable cross section)

TC ETH EXTENDER S19 - Modem



2702077

<https://www.phoenixcontact.com/us/products/2702077>

Data: USB 2.0

Connection method	USB Type B
Transmission length	< 5 m (only for configuration and diagnostics)

Dimensions

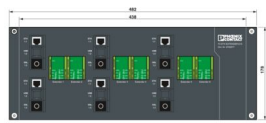
Dimensional drawing	
Width	438 mm
Height	178 mm
Depth	330 mm

Material specifications

Material (Housing)	Steel (powder-coated)
--------------------	-----------------------

Mechanical tests

Vibration resistance in accordance with EN 60068-2-6/IEC 60068-2-6	Operation: 5g, 10...150 Hz, 2.5 h, in XYZ direction
Shock in accordance with EN 60068-2-27/IEC 60068-2-27	Operation: 15g, 11 ms period, half-sine shock pulse

Environmental and real-life conditions

Ambient conditions

Degree of protection	IP20
Ambient temperature (operation)	5 °C ... 35 °C (Cabinet temperature)
Ambient temperature (storage/transport)	0 °C ... 50 °C
Permissible humidity (operation)	10 % ... 95 % (non-condensing)

Approvals

CE

Certificate	CE-compliant
-------------	--------------

EMC data

Electromagnetic compatibility	Conformance with EMC Directive 2014/30/EU
Noise immunity	EN 61000-6-2

TC ETH EXTENDER S19 - Modem



2702077

<https://www.phoenixcontact.com/us/products/2702077>

Drawings

Dimensional drawing

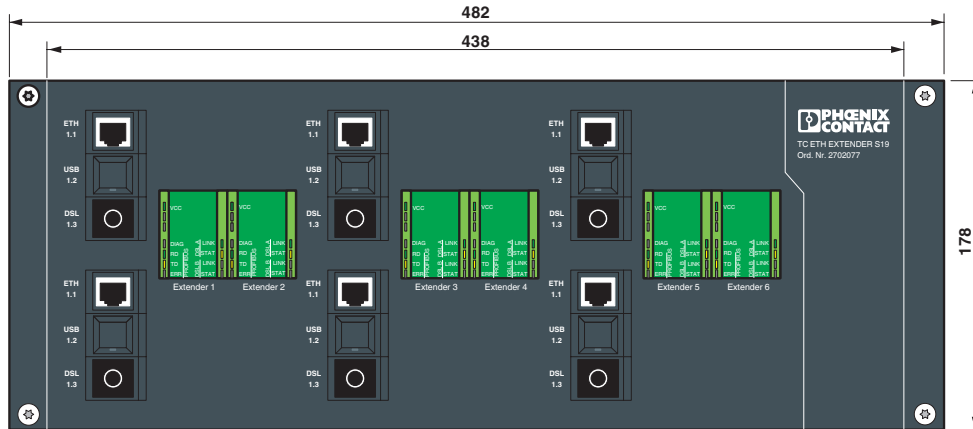

Dimensional drawing

TC ETH EXTENDER S19 - Modem



2702077

<https://www.phoenixcontact.com/us/products/2702077>

Functional drawing

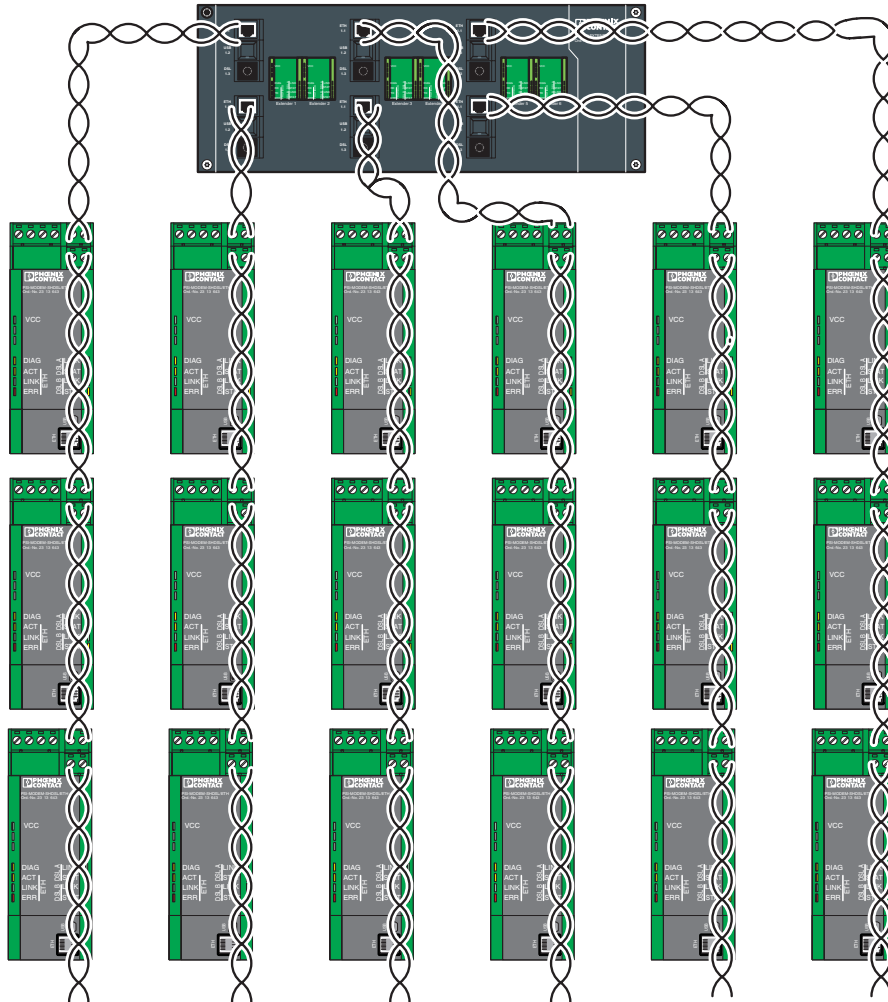

Example application

TC ETH EXTENDER S19 - Modem



2702077

<https://www.phoenixcontact.com/us/products/2702077>

Schematic diagram

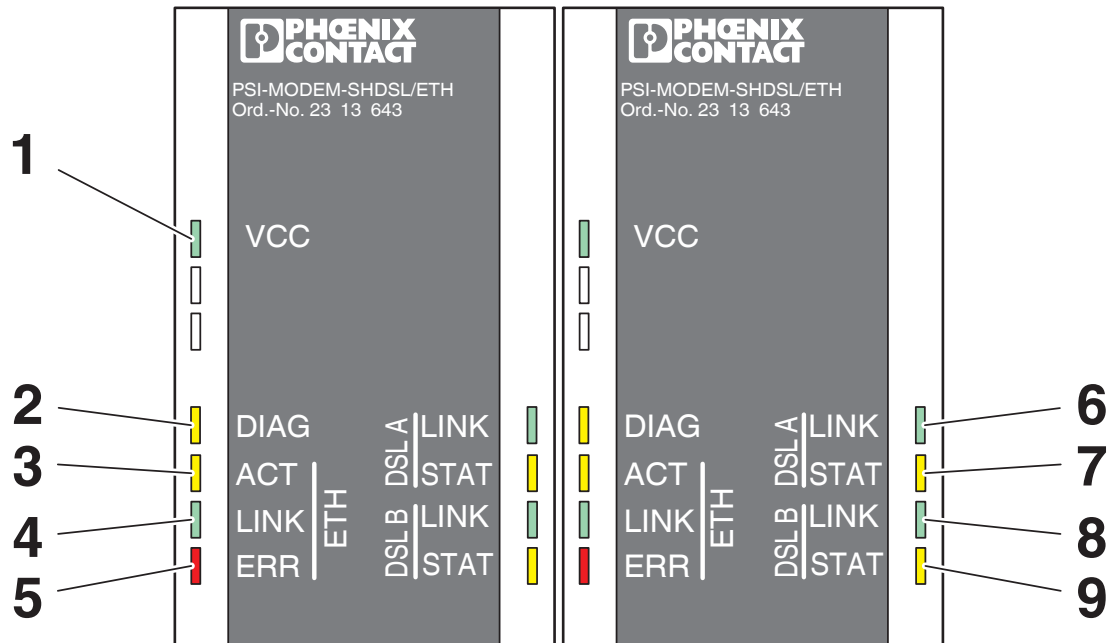

LED indicators

TC ETH EXTENDER S19 - Modem

2702077

<https://www.phoenixcontact.com/us/products/2702077>

Schematic diagram



Line structure

Schematic diagram

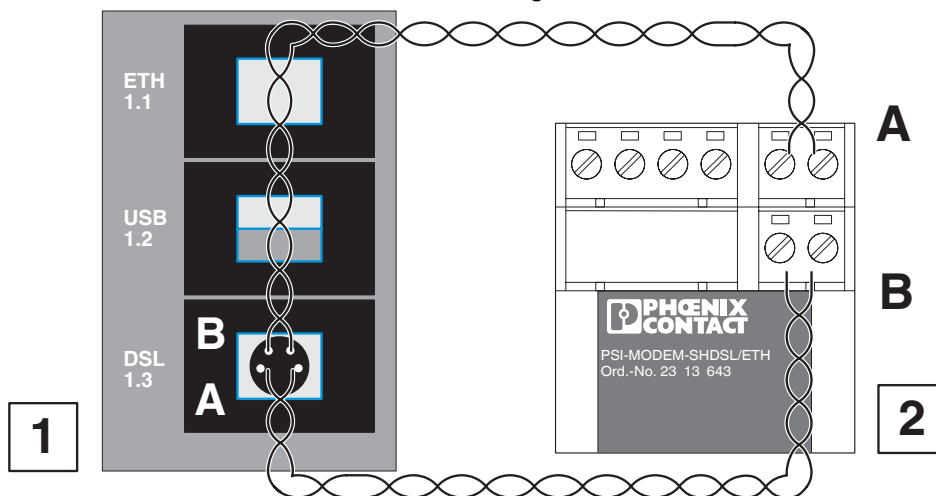

Point-to-point connection (4-wire)

TC ETH EXTENDER S19 - Modem



2702077

<https://www.phoenixcontact.com/us/products/2702077>

Schematic diagram

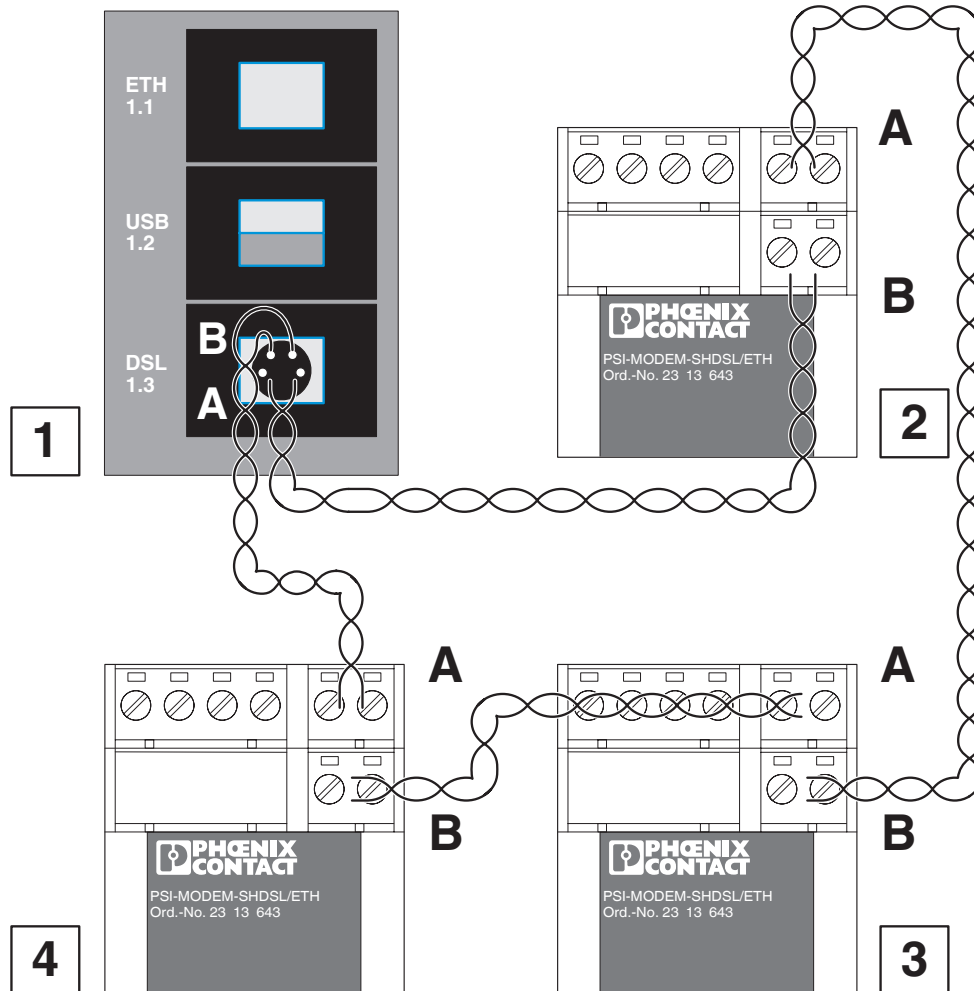

Ring structure

Schematic diagram

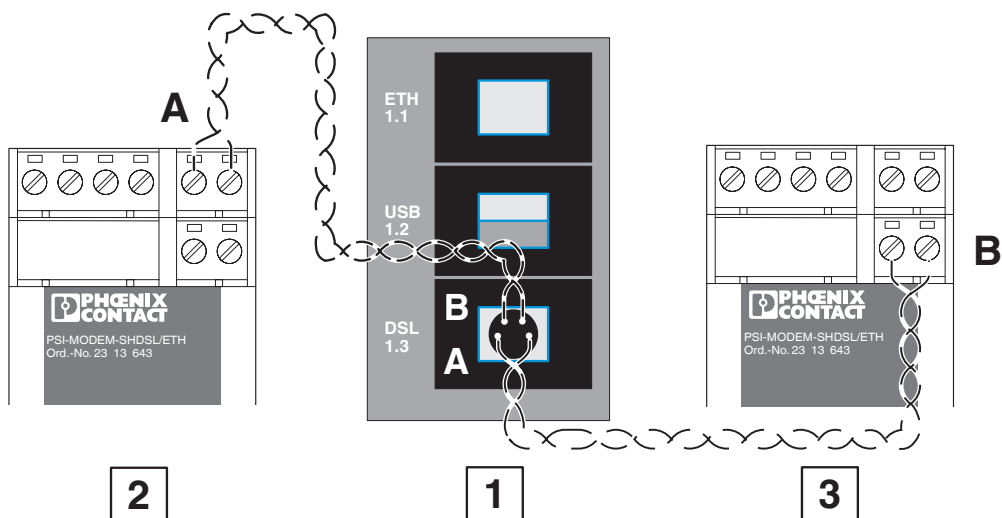

Star structure

TC ETH EXTENDER S19 - Modem



2702077

<https://www.phoenixcontact.com/us/products/2702077>

Classifications

ECLASS

ECLASS-13.0	19170407
ECLASS-15.0	19170407

ETIM

ETIM 10.0	EC000309
-----------	----------

UNSPSC

UNSPSC 21.0	43222628
-------------	----------

TC ETH EXTENDER S19 - Modem



2702077

<https://www.phoenixcontact.com/us/products/2702077>

Environmental product compliance

China RoHS

Environment friendly use period (EFUP)	EFUP-50 An article-related China RoHS declaration table can be found in the download area for the respective article under "Manufacturer declaration". For all articles with EFUP-E, no China RoHS declaration table issued and required.
--	--

EU REACH SVHC

REACH candidate substance (CAS No.)	No substance above 0.1 wt%
-------------------------------------	----------------------------

Phoenix Contact 2026 © - all rights reserved
<https://www.phoenixcontact.com>

Phoenix Contact USA
586 Fulling Mill Road
Middletown, PA 17057, United States
(+717) 944-1300
info@phoenixcon.com