

# PSD-S WIN SET-1MA-3SL/UL - Wireless elements



2701563

<https://www.phoenixcontact.com/us/products/2701563>

Please be informed that the data shown in this PDF document is generated from our online catalog. Please find the complete data in the user documentation. Our general terms of use for downloads are valid.



Set with C-UL-US approval for the WIN signal tower wireless system, consisting of one master with antenna, three slaves, software CD, USB cable (3 m), four rubber feet, and mounting material for panel mounting the master

## Your advantages

- Repeater for increasing the range integrated in each wireless element
- Existing signal towers can be extended without additional wiring
- Simultaneous detection of up to 50 wireless elements
- Can be operated parallel to other wireless applications
- Error messages can be sent via e-mail
- Range of a wireless element with a free line of sight of up to 300 m

## Commercial data

Item number	2701563
Packing unit	1 pc
Note	Made to order (non-returnable)
Sales key	DR07
Product key	DRL115
GTIN	4046356802000
Weight per piece (including packing)	518 g
Weight per piece (excluding packing)	518 g
Customs tariff number	85318095
Country of origin	DE

# PSD-S WIN SET-1MA-3SL/UL - Wireless elements



2701563

<https://www.phoenixcontact.com/us/products/2701563>

## Set consists of

### PSD-S WIN SL/UL - Wireless elements

2701565

<https://www.phoenixcontact.com/us/products/2701565>



Slave with C-UL-US approval for creating or extending the WIN signal tower wireless system, 24 V AC/DC, black

---

### PSD-S WIN MA/UL - Wireless elements

2701664

<https://www.phoenixcontact.com/us/products/2701664>



Master with antenna for the WIN signal tower wireless system, with USB interface, voltage supply via USB interface, software CD, USB cable (3 m), four rubber feet and material for panel mounting of the master

2701563

<https://www.phoenixcontact.com/us/products/2701563>

## Technical data

### Product properties

Scope of supply	1 master with antenna including accessories, 3 slaves, USB cable (3 m), software CD
-----------------	---

### Interfaces

#### Functions

Wireless licenses	USA, Canada
Country support	USA
	Canada

### EMC data

Electromagnetic compatibility	Conforms with guidelines: FCC Part 15.249/IC: RSS-210 Issue 8, RSS-GEN Issue 4, RSS-102 Issue 4
-------------------------------	---

Drawings

Dimensional drawing

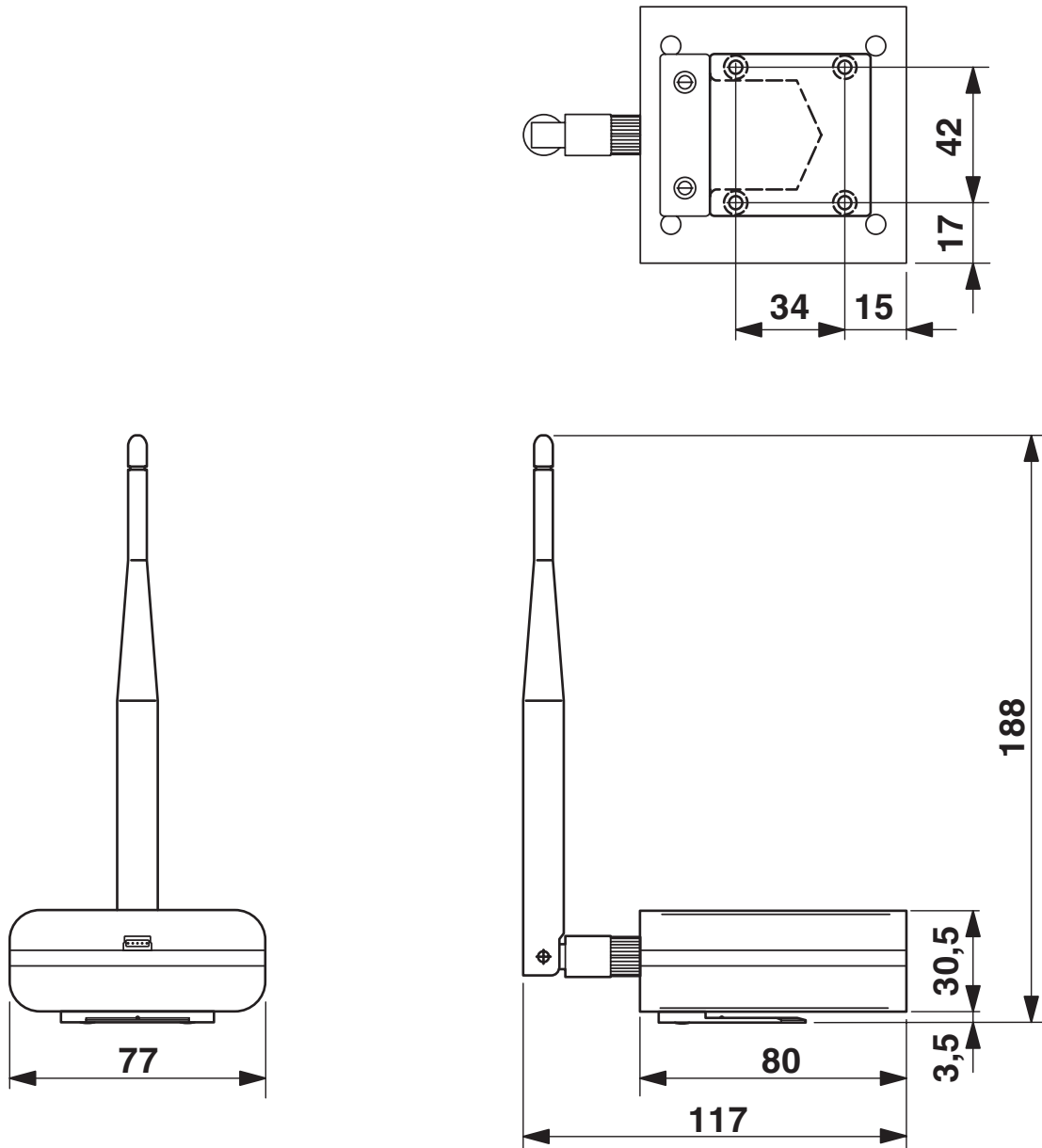

Master

Dimensional drawing

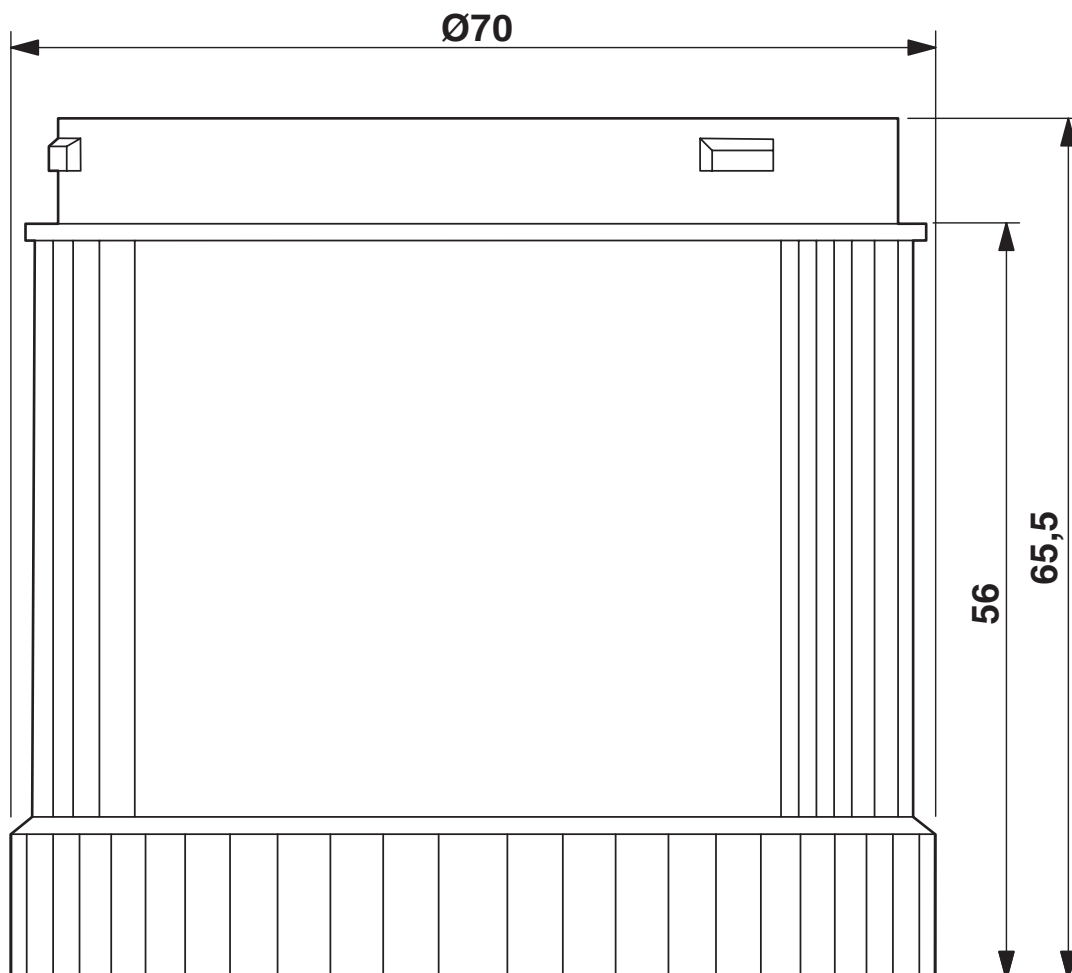

Slave

2701563

<https://www.phoenixcontact.com/us/products/2701563>

## Environmental product compliance

### EU RoHS

Fulfills EU RoHS substance requirements	Yes, No exemptions
---	--------------------

### China RoHS

Environment friendly use period (EFUP)	EFUP-E
	No hazardous substances above the limits

### EU REACH SVHC

REACH candidate substance (CAS No.)	No substance above 0.1 wt%
-------------------------------------	----------------------------

Phoenix Contact 2026 © - all rights reserved  
<https://www.phoenixcontact.com>

Phoenix Contact USA  
586 Fulling Mill Road  
Middletown, PA 17057, United States  
(+717) 944-1300  
[info@phoenixcon.com](mailto:info@phoenixcon.com)