

# AXL E S3 DIO16 M12 6P - Digital module



2701545

<https://www.phoenixcontact.com/us/products/2701545>

Please be informed that the data shown in this PDF document is generated from our online catalog. Please find the complete data in the user documentation. Our general terms of use for downloads are valid.



Axioline E, Digital I/O device, Sercos, M12 connector, Digital inputs: 16, 24 V DC, connection technology: 4-conductor, Digital outputs: 16, 24 V DC, connection technology: 3-conductor, Plastic housing, degree of protection: IP65/IP67

## Product description

The Axioline E device is designed for use within a Sercos® network. It is used to acquire and output digital signals.

## Your advantages

- Connection to Sercos network using M12 connectors (D-coded)
- Transmission speed of 100 Mbps with a minimum cycle time of 250 µs
- Connection of digital sensors and actuators using M12connectors (A-coded)
- Diagnostic and status indicators
- Short-circuit and overload protection of the sensor supply
- IP65/IP67 degree of protection

## Commercial data

Item number	2701545
Packing unit	1 pc
Minimum order quantity	1 pc
Sales key	DR04
Product key	DRI7DC
GTIN	4046356763929
Weight per piece (including packing)	559.6 g
Weight per piece (excluding packing)	480 g
Customs tariff number	85176200
Country of origin	DE

# AXL E S3 DIO16 M12 6P - Digital module



2701545

<https://www.phoenixcontact.com/us/products/2701545>

## Technical data

### Dimensions

Dimensional drawing	
Width	60 mm
Height	185 mm
Depth	30.5 mm
Drill hole spacing	198.5 mm
Note on dimensions	The height is 212 mm including fixing clips.

### Notes

#### Note on application

Note on application	Only for industrial use
---------------------	-------------------------

### Material specifications

Color (Housing)	anthracite gray (RAL 7016)
Housing material	Pocan®

### Interfaces

#### Sercos

No. of channels	2
Connection method	M12 connector
Note on the connection method	D-coded
Number of positions	4
Transmission speed	100 Mbps (with auto negotiation)

#### Sercos

Equipment type	Sercos slave
System-specific protocols	Sercos protocols Sercos Sercos protocols S/IP
Protocols supported	HTTP TFTP FTP
Specification	Sercos specification 1.1.2

### Input data

Digital:

# AXL E S3 DIO16 M12 6P - Digital module



2701545

<https://www.phoenixcontact.com/us/products/2701545>

Input name	Digital inputs
Description of the input	IEC 61131-2 types 1 and 3
Number of inputs	16
Cable length	max. 30 m (to the sensor)
Connection method	M12 connector double occupancy
Connection technology	4-conductor
Input voltage range "0" signal	0 V DC ... 5 V DC
Input voltage range "1" signal	11 V DC ... 30 V DC
Nominal input voltage $U_{IN}$	24 V DC
Nominal input current at $U_{IN}$	typ. 3 mA
Sensor current per channel	typ. 75 mA (from $U_S$ )
Total sensor current	max. 1.2 A (per device)
Input filter time	< 1000 $\mu$ s
Protective circuit	Overload protection, short-circuit protection of sensor supply

## Output data

Digital:

Output name	Digital outputs
Connection method	M12 connector double occupancy
Connection technology	3-conductor
Number of outputs	16
Protective circuit	Overload protection, short-circuit protection of outputs; yes
Output voltage	24 V DC
Limitation of the voltage induced on circuit interruption	-28 V ... -17 V
Maximum output current per channel	500 mA
Nominal output voltage	24 V DC (from voltage $U_S$ )
Output voltage range	18 V DC ... 31.2 V DC
Output voltage when switched off	max. 1 V
Output current when switched off	max. 20 $\mu$ A
Nominal load, inductive	12 VA (1.2 H, 48 $\Omega$ , with nominal voltage)
Nominal load, ohmic	12 W (48 $\Omega$ , with nominal voltage)
Switching frequency	max. 5500 per second (with at least 50 mA load current) max. 1 per second (with inductive load)
Reverse voltage resistance to short pulses	Reverse voltage proof
Behavior with overload	Auto restart
Signal delay	max. 150 $\mu$ s (when switched on) max. 200 $\mu$ s (when switched off)
Overcurrent shut-down	min. 0.7 A

## Product properties

Product type	I/O component
Product family	Axioline E
Type	Stand-alone
Special properties	Plastic housing

## Electrical properties

### Potentials

Voltage supply $U_S$	24 V DC
Power supply at $U_S$	max. 4 A
Current consumption from $U_S$	typ. 8 mA
	max. 1.2 A

### Supply: Module electronics, sensors, and actuators

Designation	Supply of module electronics, sensors, and actuators ( $U_S$ )
Connection method	M12 connector, T-coded
Number of positions	4
Supply voltage	24 V DC
Supply voltage range	18 V DC ... 31.2 V DC (including all tolerances, including ripple)
Current consumption	typ. 190 mA $\pm$ 15 % (at 24 V DC)
	max. 12 A

### Supply: Actuators

Designation	Supply of actuators ( $U_A$ ) for additional devices
Connection method	M12 connector, T-coded
Number of positions	4
Supply voltage	24 V DC
Supply voltage range	18 V DC ... 31.2 V DC (including all tolerances, including ripple)
Current consumption	typ. 3 mA $\pm$ 15 % (at 24 V DC)
	max. 12 A

### Electrical isolation/isolation of the voltage ranges

Test voltage: 24 V supply (communications power/sensor supply, digital inputs/outputs)/bus connection (Ethernet 1)	500 V AC, 50 Hz, 1 min
Test voltage: 24 V supply (communications power/sensor supply, digital inputs/outputs)/bus connection (Ethernet 2)	500 V AC, 50 Hz, 1 min
Test voltage: 24 V supply (communications power/sensor supply, digital inputs/outputs)/FE	500 V AC, 50 Hz, 1 min
Test voltage: Bus connection (Ethernet 1)/FE	500 V AC, 50 Hz, 1 min
Test voltage: Bus connection (Ethernet 2)/FE	500 V AC, 50 Hz, 1 min
Test voltage: Bus connection (Ethernet 1)/bus connection (Ethernet 2)	500 V AC, 50 Hz, 1 min
Test voltage: 24 V supply (actuator supply)/24 V supply (communications power and sensor supply, digital inputs/outputs)	500 V AC, 50 Hz, 1 min
Test voltage: 24 V supply (actuator supply)/bus connection (Ethernet 1)	500 V AC, 50 Hz, 1 min
Test voltage: 24 V supply (actuator supply)/bus connection (Ethernet 2)	500 V AC, 50 Hz, 1 min
Test voltage: 24 V supply (actuator supply)/FE	500 V AC, 50 Hz, 1 min

## Connection data

2701545

<https://www.phoenixcontact.com/us/products/2701545>

Connection method	M12 connector
-------------------	---------------

## Environmental and real-life conditions

### Ambient conditions

Ambient temperature (operation)	-25 °C ... 60 °C
Degree of protection	IP65/IP67
Air pressure (operation)	70 kPa ... 106 kPa (up to 3000 m above sea level)
Air pressure (storage/transport)	70 kPa ... 106 kPa (up to 3000 m above sea level)
Ambient temperature (storage/transport)	-25 °C ... 85 °C
Permissible humidity (operation)	5 % ... 95 %
Permissible humidity (storage/transport)	5 % ... 95 %

### Mechanical test

Vibration resistance in accordance with EN 60068-2-6/IEC 60068-2-6	5g
Shock in accordance with EN 60068-2-27/IEC 60068-2-27	30g, 11 ms period, half-sine shock pulse
Continuous shock in accordance with EN 60068-2-27/IEC 60068-2-27	10g

## Standards and regulations

Protection class	III (IEC 61140, EN 61140, VDE 0140-1)
------------------	---------------------------------------

## Mounting

Mounting type	Screw mounting
---------------	----------------

# AXL E S3 DIO16 M12 6P - Digital module



2701545

<https://www.phoenixcontact.com/us/products/2701545>

## Drawings

Dimensional drawing

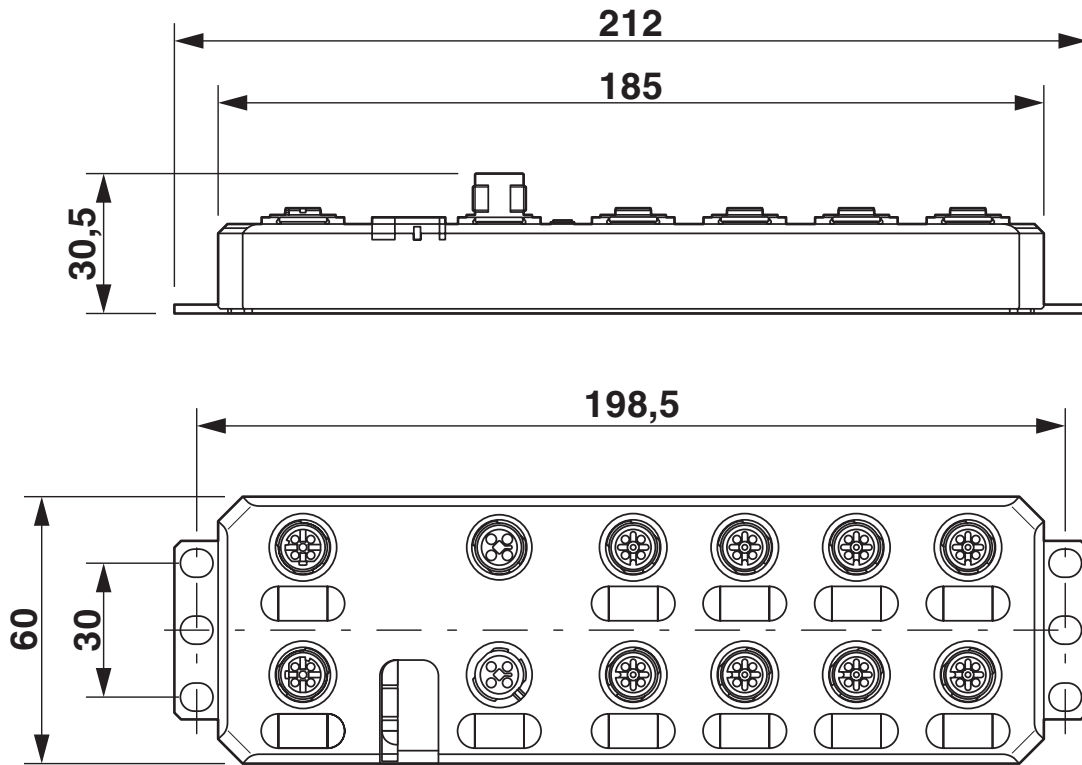

Connection diagram

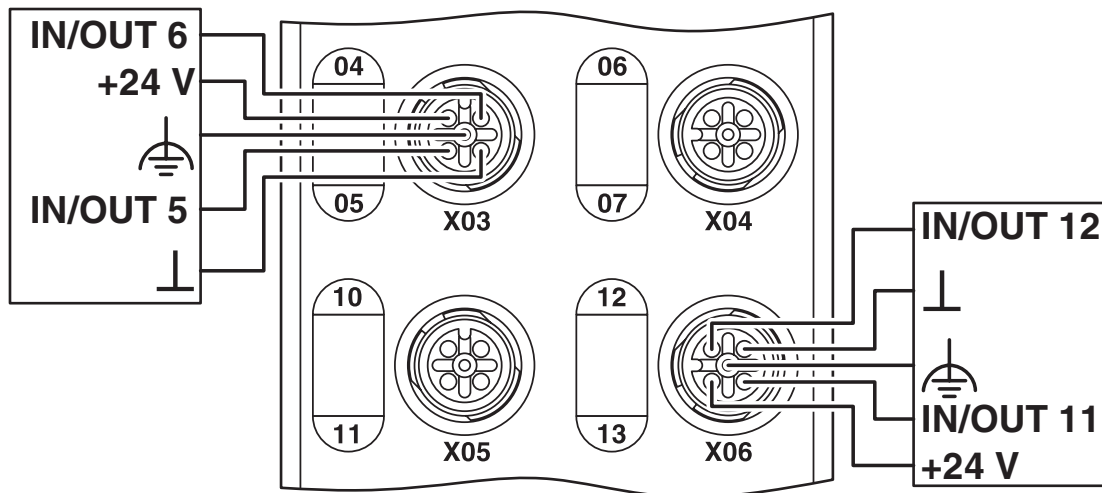

# AXL E S3 DIO16 M12 6P - Digital module



2701545

<https://www.phoenixcontact.com/us/products/2701545>

## Approvals

🔗 To download certificates, visit the product detail page: <https://www.phoenixcontact.com/us/products/2701545>

**sercos**

Approval ID: C-S3-1.0041



**cULus Listed**

Approval ID: E140324



**cULus Listed**

Approval ID: E199827

# AXL E S3 DIO16 M12 6P - Digital module



2701545

<https://www.phoenixcontact.com/us/products/2701545>

## Classifications

### ECLASS

ECLASS-13.0	27242604
ECLASS-15.0	27242604

### ETIM

ETIM 10.0	EC001599
-----------	----------

### UNSPSC

UNSPSC 21.0	32151600
-------------	----------

## Environmental product compliance

### China RoHS

Environment friendly use period (EFUP)	EFUP-25
	An article-related China RoHS declaration table can be found in the download area for the respective article under "Manufacturer declaration". For all articles with EFUP-E, no China RoHS declaration table issued and required.

### EU REACH SVHC

REACH candidate substance (CAS No.)	No substance above 0.1 wt%
-------------------------------------	----------------------------

Phoenix Contact 2026 © - all rights reserved  
<https://www.phoenixcontact.com>

Phoenix Contact USA  
586 Fulling Mill Road  
Middletown, PA 17057, United States  
(+717) 944-1300  
[info@phoenixcon.com](mailto:info@phoenixcon.com)