

# PSD-S OE FL GN - Optical element



2700102

<https://www.phoenixcontact.com/us/products/2700102>

Please be informed that the data shown in this PDF document is generated from our online catalog. Please find the complete data in the user documentation. Our general terms of use for downloads are valid.

Flashing beacon element, 24 V DC, green, Xenon flash tube



## Your advantages

- At least 4 million flashes
- Degree of protection IP65
- Tool-free element changeover
- Can be freely combined
- High light and color intensity

## Commercial data

Item number	2700102
Packing unit	1 pc
Note	Made to order (non-returnable)
Sales key	DR07
Product key	DRL111
GTIN	4046356491044
Weight per piece (including packing)	87.8 g
Weight per piece (excluding packing)	87.8 g
Customs tariff number	85318095
Country of origin	DE

# PSD-S OE FL GN - Optical element



2700102

<https://www.phoenixcontact.com/us/products/2700102>

## Technical data

### Product properties

Product type	Optical element
Area of application	Signal tower

### Electrical properties

Maximum power dissipation for nominal condition	4.8 W
---	-------

### General

Input voltage	24 V DC
Maximum inrush current	max. 200 mA
Current consumption	125 mA
Source of light type	Xenon flash tube
Operating time	100 %
Service life electrical	4 million flashes, minimum
Optical signal type	Flashing light
Signal frequency	approx. 1 Hz

### Dimensions

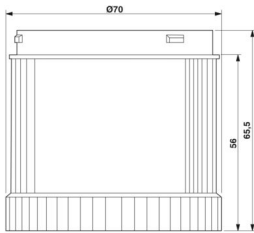
Dimensional drawing	
Height	65.5 mm
Diameter	70 mm

### Material specifications

Calotte color	green
Material	Polycarbonate PC

### Environmental and real-life conditions

#### Ambient conditions

Degree of protection	IP65 (when installed or with end cover)
Ambient temperature (operation)	-20 °C ... 50 °C

### EMC data

Electromagnetic compatibility	Conformance with EMC Directive 2014/30/EU
-------------------------------	---

### Mounting

# PSD-S OE FL GN - Optical element



2700102

<https://www.phoenixcontact.com/us/products/2700102>

Assembly note	Rubber seal pre-installed for each element
Mounting position	any

Drawings

Dimensional drawing



# PSD-S OE FL GN - Optical element



2700102

<https://www.phoenixcontact.com/us/products/2700102>

## Environmental product compliance

### China RoHS

Environment friendly use period (EFUP)	EFUP-50
	An article-related China RoHS declaration table can be found in the download area for the respective article under "Manufacturer declaration". For all articles with EFUP-E, no China RoHS declaration table issued and required.

### EU REACH SVHC

REACH candidate substance (CAS No.)	No substance above 0.1 wt%
-------------------------------------	----------------------------

Phoenix Contact 2026 © - all rights reserved  
<https://www.phoenixcontact.com>

Phoenix Contact USA  
586 Fulling Mill Road  
Middletown, PA 17057, United States  
(+717) 944-1300  
[info@phoenixcon.com](mailto:info@phoenixcon.com)