

GW PL FF/HART - Protocol converter



2316360

<https://www.phoenixcontact.com/us/products/2316360>

Please be informed that the data shown in this PDF document is generated from our online catalog. Please find the complete data in the user documentation. Our general terms of use for downloads are valid.

HART to Foundation Fieldbus protocol converter



Product description

Protocol converter capable of connecting four HART (4-20 mA) devices to a Foundation Fieldbus network

Commercial data

Item number	2316360
Packing unit	1 pc
Minimum order quantity	1 pc
Sales key	DN11
Product key	DNC135
GTIN	4055626128320
Weight per piece (including packing)	271 g
Weight per piece (excluding packing)	270.8 g
Customs tariff number	85176200
Country of origin	US

Technical data

Notes

Note on application

Note on application	Only for industrial use
---------------------	-------------------------

Utilization restriction

EMC note	EMC: class A product, see manufacturer's declaration in the download area
----------	---

Product properties

Product type	Interface converter
--------------	---------------------

Insulation characteristics

Overvoltage category	II
Degree of pollution	2

Electrical properties

Supply

Supply voltage range	18.5 V DC ... 30 V DC
Nominal supply voltage	24 V DC
Max. current consumption	70 mA

Connection data

Supply

Connection method	COMBICON plug-in screw terminal block
Conductor cross-section, flexible	0.20 mm ² ... 2.50 mm ²
Conductor cross-section, rigid	0.20 mm ² ... 2.50 mm ²
Conductor cross-section AWG	24 ... 12
Tightening torque	0.5 Nm ... 0.6 Nm

Interfaces

Data: FOUNDATION Fieldbus

Data rate	31.25 kbps
Number of connections	1
Connection method	COMBICON
No. of channels	1
Tightening torque	0.5 Nm ... 0.6 Nm
Connection technology	Screw connection
Termination resistor	Switchable
Conductor cross-section flexible max.	2.5 mm ²
Conductor cross-section flexible min.	0.2 mm ²
Conductor cross-section, rigid max.	2.5 mm ²

GW PL FF/HART - Protocol converter

2316360

<https://www.phoenixcontact.com/us/products/2316360>

Conductor cross-section, rigid min.	0.2 mm ²
Conductor cross-section AWG max.	12
Conductor cross-section AWG min.	24
Protocols supported	HART, FOUNDATION Fieldbus

Data: HART FSK

Number of connections	3
Connection method	COMBICON
No. of channels	4 (Active/Passive HART devices)
Tightening torque	0.5 Nm ... 0.6 Nm
Connection technology	Screw connection
Conductor cross-section flexible max.	2.5 mm ²
Conductor cross-section flexible min.	0.2 mm ²
Conductor cross-section, rigid max.	2.5 mm ²
Conductor cross-section, rigid min.	0.02 mm ²
Conductor cross-section AWG max.	12
Conductor cross-section AWG min.	24

Dimensions

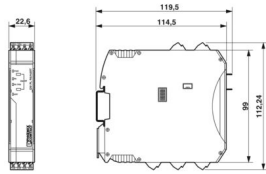
Dimensional drawing	
Width	22.5 mm
Height	99 mm
Depth	114.5 mm

Material specifications

Color (Housing)	light gray (RAL 7035)
Housing material	PA V0

Environmental and real-life conditions

Ambient conditions

Degree of protection	IP20
Ambient temperature (operation)	-40 °C ... 85 °C
Ambient temperature (storage/transport)	-40 °C ... 85 °C
Altitude	2000 m
Permissible humidity (operation)	95 % (non-condensing)
Shock	30g, 18 ms
Vibration (operation)	10 Hz ... 150 Hz, 5g

Approvals

GW PL FF/HART - Protocol converter



2316360

<https://www.phoenixcontact.com/us/products/2316360>

Ex data

ATEX	PRESAFE 16ATEX7686X, II 3G, Ex nA IIC T4 Gc
IECEX	IECEX PRE 16.0001X, Ex nA IIC T4 Gc
UL, USA / Canada	Class I, Div. 2, Groups A, B, C, D Class I, Zone 2, AEx nA IIC T4, Ex nA IIC T4 GcX

Standards and regulations

Standards/regulations	IEC 60079-15
	IEC 60079-0

Mounting

Mounting type	DIN rail mounting
Assembly note	on standard DIN rail NS 35 in accordance with EN 60715
Mounting position	on horizontal DIN rail NS 35 in acc. with EN 60715
Useable DIN rail type	DIN rail: 35 mm

GW PL FF/HART - Protocol converter



2316360

<https://www.phoenixcontact.com/us/products/2316360>

Drawings

Dimensional drawing

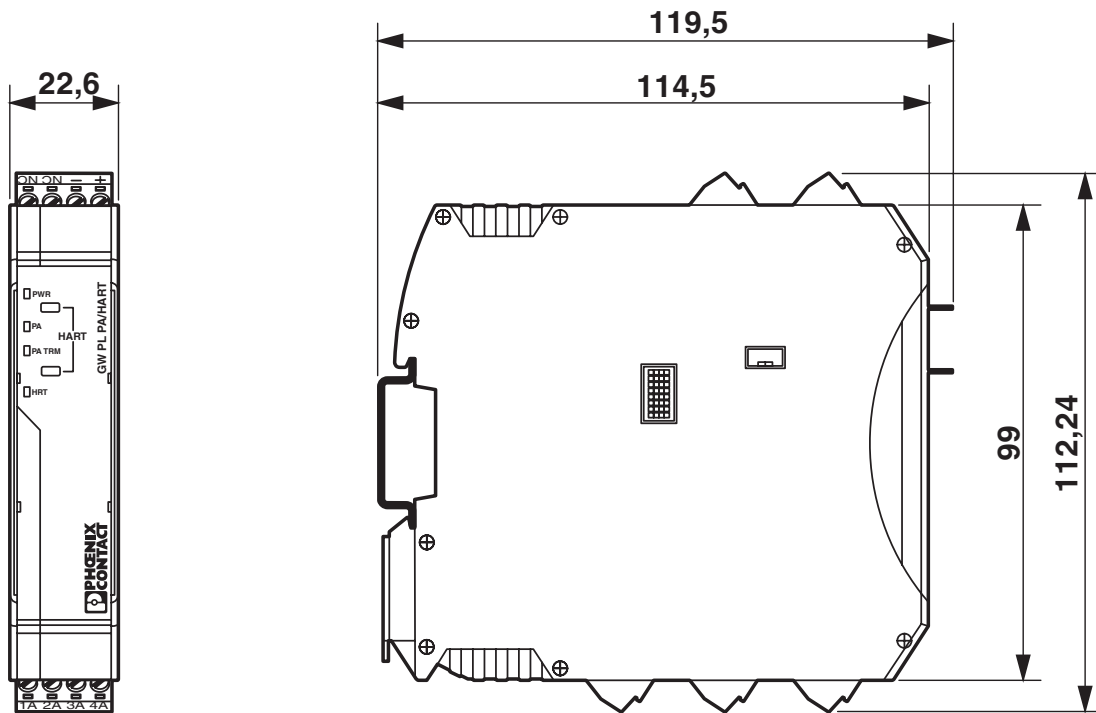

GW PL FF/HART - Protocol converter



2316360

<https://www.phoenixcontact.com/us/products/2316360>

Approvals

To download certificates, visit the product detail page: <https://www.phoenixcontact.com/us/products/2316360>



IECEX

Approval ID: IECEX PRE 16 0001X



cUL Listed

Approval ID: E199827



UL Listed

Approval ID: E199827



ATEX

Approval ID: Presafe16ATEX7686X 2

GW PL FF/HART - Protocol converter



2316360

<https://www.phoenixcontact.com/us/products/2316360>

Classifications

ECLASS

ECLASS-13.0	27242208
ECLASS-15.0	27242208

UNSPSC

UNSPSC 21.0	32151700
-------------	----------

GW PL FF/HART - Protocol converter



2316360

<https://www.phoenixcontact.com/us/products/2316360>

Environmental product compliance

EU RoHS

Fulfills EU RoHS substance requirements	Yes, No exemptions
---	--------------------

China RoHS

Environment friendly use period (EFUP)	EFUP-E
	No hazardous substances above the limits

EU REACH SVHC

REACH candidate substance (CAS No.)	No substance above 0.1 wt%
-------------------------------------	----------------------------

Phoenix Contact 2026 © - all rights reserved
<https://www.phoenixcontact.com>

Phoenix Contact USA
586 Fulling Mill Road
Middletown, PA 17057, United States
(+717) 944-1300
info@phoenixcon.com