

PSI-GSM-STUB-ANT - Antenna

2313342

<https://www.phoenixcontact.com/us/products/2313342>

Please be informed that the data shown in this PDF document is generated from our online catalog. Please find the complete data in the user documentation. Our general terms of use for downloads are valid.



Mobile communication antenna for direct mounting on the device, SMA (male) antenna connector with articulated joint. The antenna is suitable for installation in plastic control cabinets not visible from the outside.

Commercial data

Item number	2313342
Packing unit	1 pc
Sales key	DN25
Product key	DNC4Z1
GTIN	4046356353212
Weight per piece (including packing)	11.11 g
Weight per piece (excluding packing)	10.4 g
Customs tariff number	85177100
Country of origin	TW

PSI-GSM-STUB-ANT - Antenna

2313342

<https://www.phoenixcontact.com/us/products/2313342>

Technical data

Product properties

Product type	Antenna
Radiation characteristics	Omnidirectional
Gain	typ. 0 dB
Polarization	Linear vertical

Electrical properties

Frequency band	2100 MHz
	1900 MHz
	1800 MHz
	900 MHz
	850 MHz
Frequency range	850 MHz ... 900 MHz
	1.8 GHz ... 2.1 GHz
Impedance	50 Ω
Voltage standing wave ratio VSWR in a 50 Ω system	< 2.00

Connection data

Connection technology

Connection method	SMA (male)
-------------------	------------

Dimensions

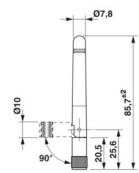
Dimensional drawing	
Height	86 mm
Diameter	10 mm

Cable/line

Connecting cable	no
------------------	----

Environmental and real-life conditions

Ambient conditions

Degree of protection	IP54
Ambient temperature (operation)	-40 °C ... 105 °C
Ambient temperature (storage/transport)	-40 °C ... 105 °C

Mounting

PSI-GSM-STUB-ANT - Antenna



2313342

<https://www.phoenixcontact.com/us/products/2313342>

Mounting type	Direct assembly on the device interface
---------------	---

PSI-GSM-STUB-ANT - Antenna

2313342

<https://www.phoenixcontact.com/us/products/2313342>



Drawings

Dimensional drawing

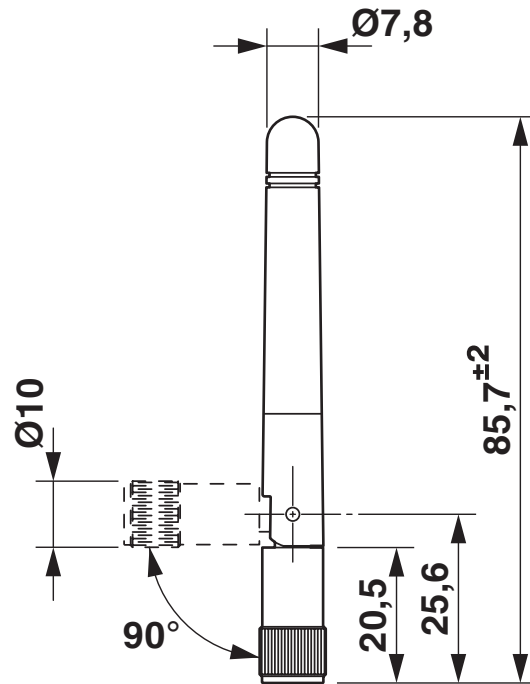

Dimensional drawing

PSI-GSM-STUB-ANT - Antenna



2313342

<https://www.phoenixcontact.com/us/products/2313342>

Classifications

ECLASS

ECLASS-13.0

19070105

ETIM

ETIM 9.0

EC001698

UNSPSC

UNSPSC 21.0

43223100

2313342

<https://www.phoenixcontact.com/us/products/2313342>

Environmental product compliance

EU RoHS

Fulfills EU RoHS substance requirements	Yes
Exemption	6(c)

China RoHS

Environment friendly use period (EFUP)	EFUP-50
	An article-related China RoHS declaration table can be found in the download area for the respective article under "Manufacturer declaration". For all articles with EFUP-E, no China RoHS declaration table issued and required.

EU REACH SVHC

REACH candidate substance (CAS No.)	Lead(CAS: 7439-92-1)
SCIP	d224f20e-f5e7-45d0-ba4d-da07024b5355

Phoenix Contact 2026 © - all rights reserved

<https://www.phoenixcontact.com>

Phoenix Contact USA
586 Fulling Mill Road
Middletown, PA 17057, United States
(+717) 944-1300
info@phoenixcon.com