

# FLKM 14-PA-INLINE/32 - Front adapter



2302777

<https://www.phoenixcontact.com/us/products/2302777>

Please be informed that the data shown in this PDF document is generated from our online catalog. Please find the complete data in the user documentation. Our general terms of use for downloads are valid.

VARIOFACE front adapter for Inline modules, for transferring 32 (4 x 8) digital signals.

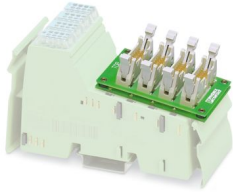

## Commercial data

Item number	2302777
Packing unit	1 pc
Minimum order quantity	1 pc
Sales key	C421
Product key	DK231P
GTIN	4017918929466
Weight per piece (including packing)	69.2 g
Weight per piece (excluding packing)	44.67 g
Customs tariff number	85369010
Country of origin	DE

# FLKM 14-PA-INLINE/32 - Front adapter



2302777

<https://www.phoenixcontact.com/us/products/2302777>

## Technical data

### Product properties

Product type	Front adapter
Product family	VARIOFACE

#### Insulation characteristics: Air clearances and creepage distances

Insulation	Functional insulation
Overvoltage category	II
Pollution degree	2

### Electrical properties

Operating voltage (DC)	≤ 60 V DC
Current (per branch)	≤ 1 A

#### Air clearances and creepage distances

Rated insulation voltage	63 V
Rated surge voltage	0.6 kV (1.2/50 μs)

#### Supported controller: PHOENIX CONTACT Inline

Suitable I/O card	IB IL 24 DI 32/HD-PAC
	IB IL 24 DO 32/HD-PAC
	IB IL 24 DI 32/HD-NPN-PAC

## Connection data

#### Connection 1 (control level)

Connection method	Plug-in connection
Number of connections	1
Number of positions	32

#### Connection 2 (field level)

Connection in acc. with standard	IEC 60603-13
Connection method	IDC/FLK pin strip
Number of connections	4
Number of positions	14
Insertion/withdrawal cycles	> 50
Pitch	2.54 mm

## Dimensions

#### Item dimensions

Width	44 mm
Height	66.5 mm
Depth	33.85 mm

## Environmental and real-life conditions

# FLKM 14-PA-INLINE/32 - Front adapter



2302777

<https://www.phoenixcontact.com/us/products/2302777>

## Ambient conditions

Degree of protection (Module)	IP20
Degree of protection (Installation location)	≥ IP54
Ambient temperature (operation)	-20 °C ... 50 °C
Ambient temperature (storage/transport)	-20 °C ... 50 °C
Altitude	≤ 2000 m

## Standards and regulations

### Air clearances and creepage distances

Standards/regulations	EN IEC 60664-1
-----------------------	----------------

## Mounting

Mounting type	Plug-in mounting
Mounting position	any

## Notes

Notes on operation	For proper use, the specifications of the installation directive (see Downloads) must be observed. For applications or use with third-party products, the specifications, and the safety and warning instructions of the respective third-party manufacturer must also be met.
--------------------	--

# FLKM 14-PA-INLINE/32 - Front adapter



2302777

<https://www.phoenixcontact.com/us/products/2302777>

## Drawings

Connection diagram

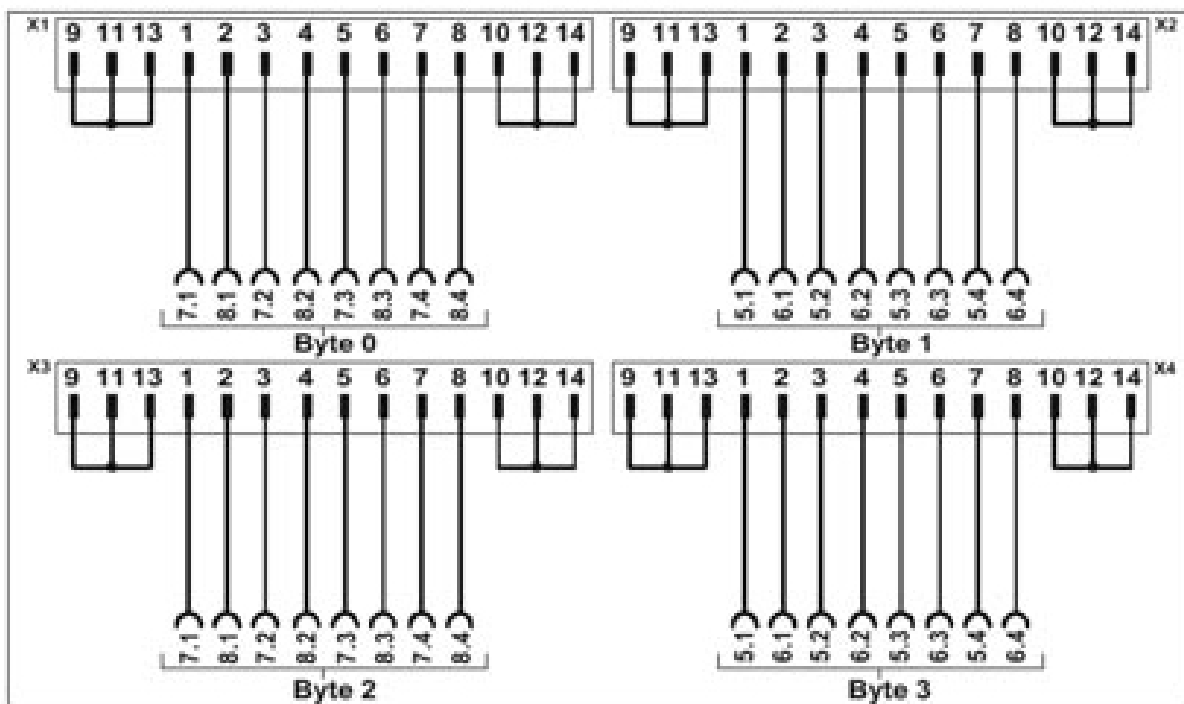

# FLKM 14-PA-INLINE/32 - Front adapter



2302777

<https://www.phoenixcontact.com/us/products/2302777>

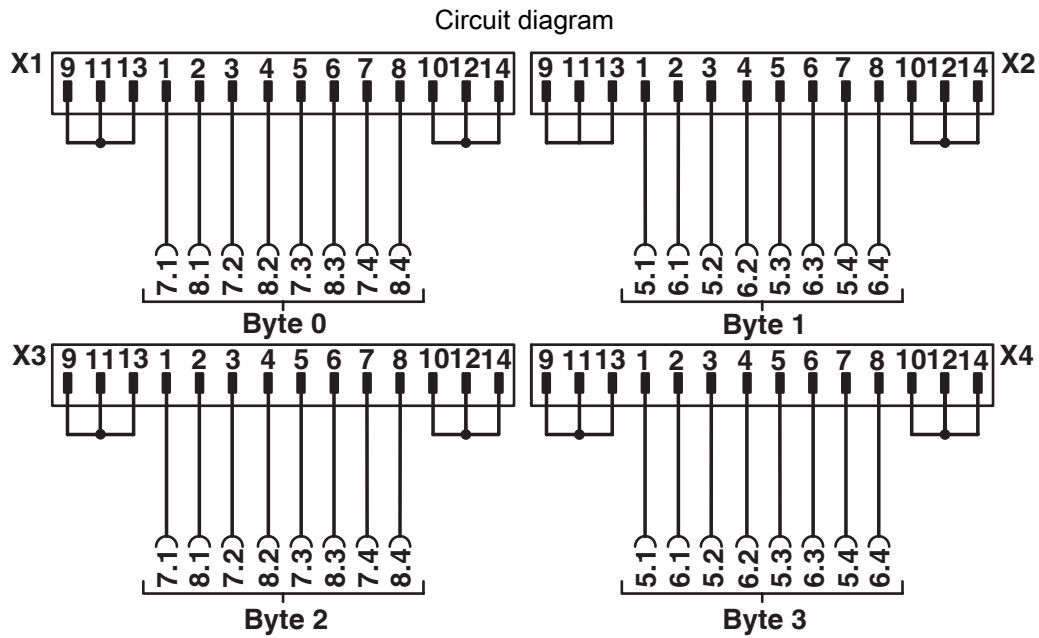

Connection scheme: FLKM 14-PA-INLINE/32

# FLKM 14-PA-INLINE/32 - Front adapter



2302777

<https://www.phoenixcontact.com/us/products/2302777>

## Classifications

### ECLASS

ECLASS-13.0	27242292
ECLASS-15.0	27242292

### ETIM

ETIM 10.0	EC002584
-----------	----------

### UNSPSC

UNSPSC 21.0	32151600
-------------	----------

# FLKM 14-PA-INLINE/32 - Front adapter



2302777

<https://www.phoenixcontact.com/us/products/2302777>

## Environmental product compliance

### EU RoHS

Fulfills EU RoHS substance requirements	Yes
Exemption	6(c)

### China RoHS

Environment friendly use period (EFUP)	EFUP-50
	An article-related China RoHS declaration table can be found in the download area for the respective article under "Manufacturer declaration". For all articles with EFUP-E, no China RoHS declaration table issued and required.

### EU REACH SVHC

REACH candidate substance (CAS No.)	Lead(CAS: 7439-92-1)
SCIP	288af150-c33f-4be6-937f-12dc4efa4977

Phoenix Contact 2026 © - all rights reserved

<https://www.phoenixcontact.com>

Phoenix Contact USA  
586 Fulling Mill Road  
Middletown, PA 17057, United States  
(+717) 944-1300  
[info@phoenixcon.com](mailto:info@phoenixcon.com)