

ELR W3- 24DC/500AC- 2I-BR - Hybrid motor starter



2297109

<https://www.phoenixcontact.com/us/products/2297109>

Please be informed that the data shown in this PDF document is generated from our online catalog. Please find the complete data in the user documentation. Our general terms of use for downloads are valid.



Hybrid motor starter for reversing 3~ AC motors up to 550 V AC, with 24 V DC input, 2.4 A output current, adjustable overload shutdown, and limited phase failure detection

Your advantages

- 22.5 mm wide
- Reduction in wiring
- Long service life
- Space saving
- 3-phase loop bridges
- Adjustable current for bimetal function
- Low-wear switching

Commercial data

Item number	2297109
Packing unit	1 pc
Minimum order quantity	1 pc
Sales key	C470
Product key	DK7422
GTIN	4046356428347
Weight per piece (including packing)	301.6 g
Weight per piece (excluding packing)	300 g
Customs tariff number	85371098
Country of origin	DE

Technical data

Product properties

Product type	Hybrid motor starters
Product family	CONTACTRON
Operating mode	100% operating factor

Electrical properties

Number of phases	3
Motor starter type	Reversing starter
Switching frequency	≤ 2 Hz (Load-dependent)
Switching frequency	≤ 2 Hz (Load-dependent)
Maximum power dissipation	3.3 W
Minimum power dissipation	1.1 W

Supply

Rated control circuit supply voltage U_S	24 V DC
Control supply voltage range	19.2 V DC ... 30 V DC
Rated control supply current I_S	40 mA
Protective circuit	Surge protection
	Reverse polarity protection

Insulation characteristics

Rated insulation voltage	500 V
Rated surge voltage	6 kV
Overvoltage category	III
Degree of pollution	2
Insulation characteristics between the control input and control supply voltage, and auxiliary circuit to the main circuit	Safe isolation (IEC 60947-1) at operating voltage ≤ 300 V AC
	Basic insulation (IEC 60947-1) at operating voltage 300 V AC ... 500 V AC
	Safe isolation (IEC 60947-1) in the auxiliary circuit ≤ 300 V AC

Input data

Control

Input name	Control input right/left
Rated actuating voltage U_C	24 V DC
Triggering voltage range	19.2 V DC ... 30 V DC
Rated actuating current I_C	5 mA (Input type 1)
Switching threshold	9.6 V ("0" signal)
	19.2 V ("1" signal)
Typical response time	< 35 ms
Typical turn-off time	< 40 ms
Protective circuit	Reverse polarity protection

ELR W3- 24DC/500AC- 2I-BR - Hybrid motor starter



2297109

<https://www.phoenixcontact.com/us/products/2297109>

Output data

AC output

Rated operating voltage U_e	500 V AC
Operating voltage range	42 V AC ... 550 V AC
Rated operating current I_e	2.4 A (AC-51) 2.4 A (AC-53a)
Mains frequency	50/60 Hz
Load current range	180 mA ... 2.4 A (see to derating)
Trigger characteristic in acc. with IEC 60947-4-2	Class 10A
Cooling time	20 min (for auto reset)
Leakage current	0 mA
Protective circuit	Surge protection

Acknowledge output

Note	Confirmation 01: floating changeover contact
Contact switching type	1 changeover contact
Switching capacity in accordance with IEC 60947-5-1	3 A (230 V, AC15) 2 A (24 V (DC13))

Connection data

Control circuits

Connection method	Screw connection
Stripping length	8 mm
Screw thread	M3
Conductor cross-section rigid	0.2 mm ² ... 2.5 mm ²
Conductor cross-section flexible	0.2 mm ² ... 2.5 mm ²
Conductor cross-section AWG	24 ... 14
Tightening torque	0.5 Nm ... 0.6 Nm 5 lb _F -in. ... 7 lb _F -in.

Load circuit

Connection method	Screw connection
Stripping length	8 mm
Screw thread	M3
Conductor cross-section rigid	0.2 mm ² ... 2.5 mm ²
Conductor cross-section flexible	0.2 mm ² ... 2.5 mm ²
Conductor cross-section AWG	24 ... 14
Tightening torque	0.5 Nm ... 0.6 Nm 5 lb _F -in. ... 7 lb _F -in.

Signaling

Status display	LED (yellow)
Operating voltage display	Green LED

ELR W3- 24DC/500AC- 2I-BR - Hybrid motor starter



2297109

<https://www.phoenixcontact.com/us/products/2297109>

Error indication	Red LED
------------------	---------

Dimensions

Width	22.5 mm
Height	107 mm
Depth	114 mm

Material specifications

Flammability rating according to UL 94 (Housing)	V0 (Housing)
--	--------------

Environmental and real-life conditions

Ambient conditions

Degree of protection	IP20
Ambient temperature (operation)	-25 °C ... 70 °C (observe derating)
Ambient temperature (storage/transport)	-40 °C ... 80 °C
Altitude	≤ 2000 m

Standards and regulations

Standards/regulations

Standards/regulations	IEC 60947-1
-----------------------	-------------

Mounting

Mounting type	DIN rail mounting
Assembly note	can be aligned with spacing: see derating
Mounting position	Vertical (horizontal DIN rail)

Drawings

Diagram

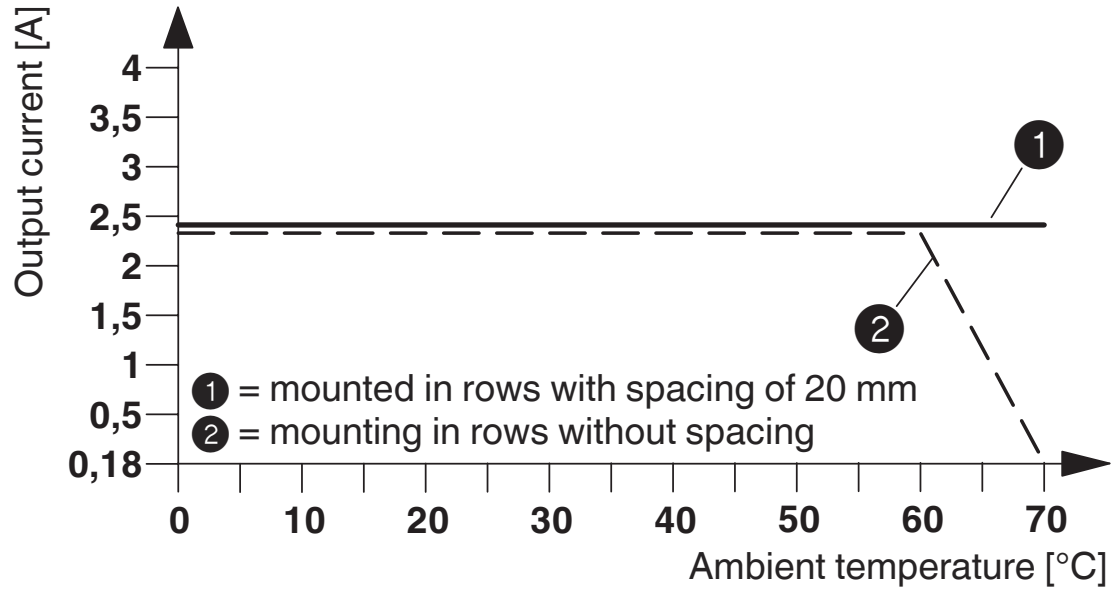

Derating diagram

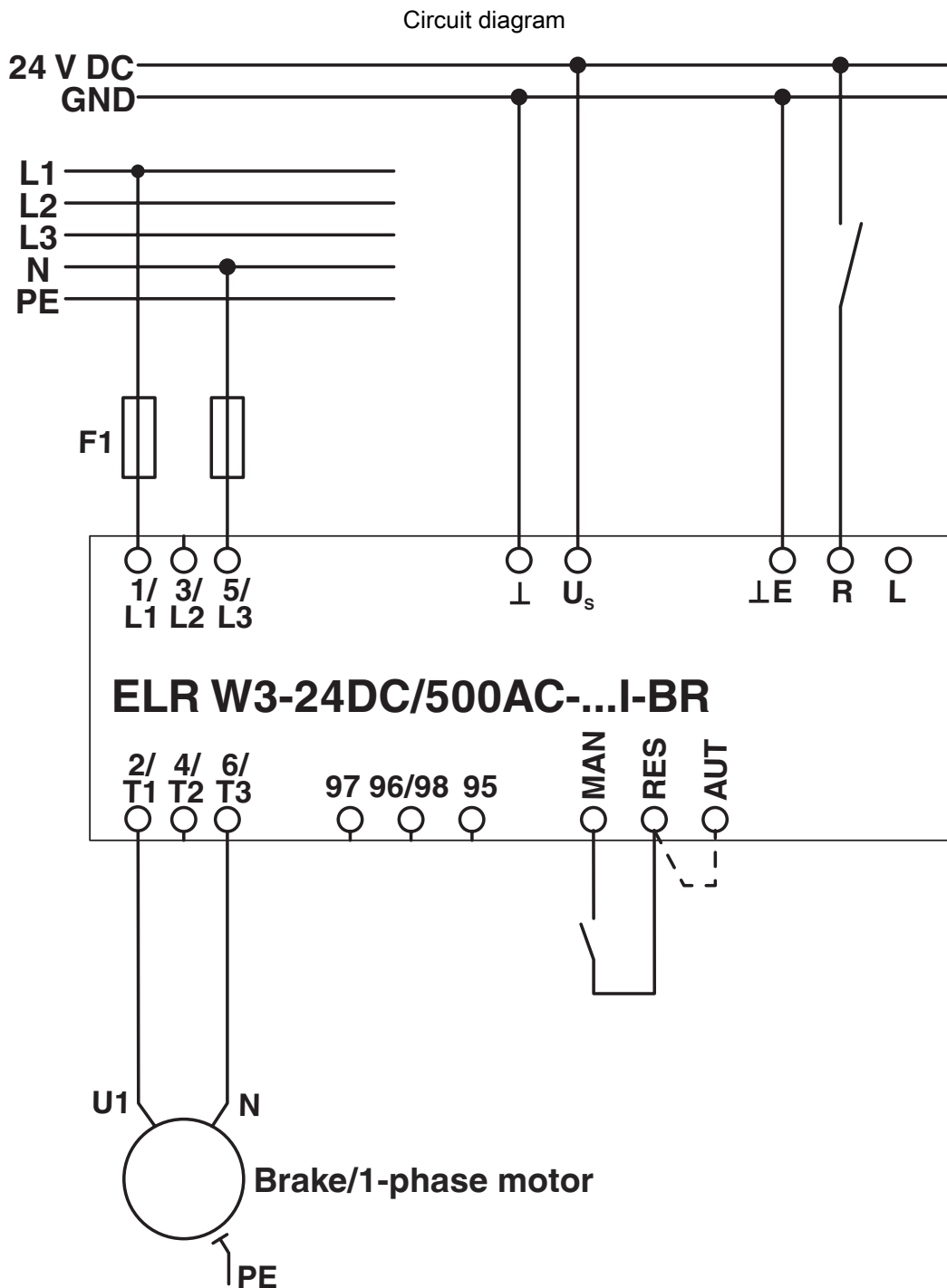

Example circuit for the connection of a brake or a 1-phase motor (L1 + N)

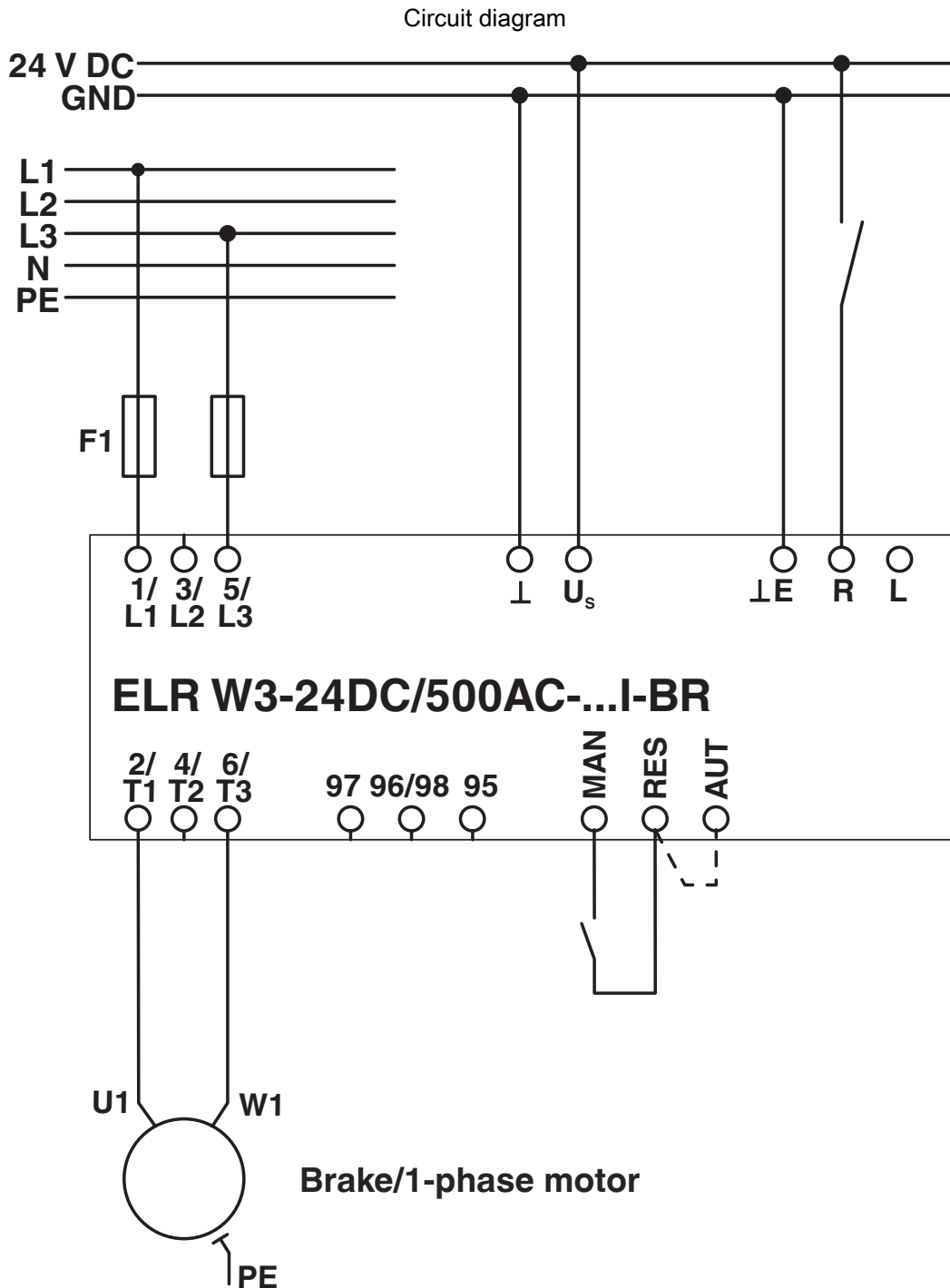

Example circuit for the connection of a brake or a 1-phase motor (L1 + L3)

Block diagram

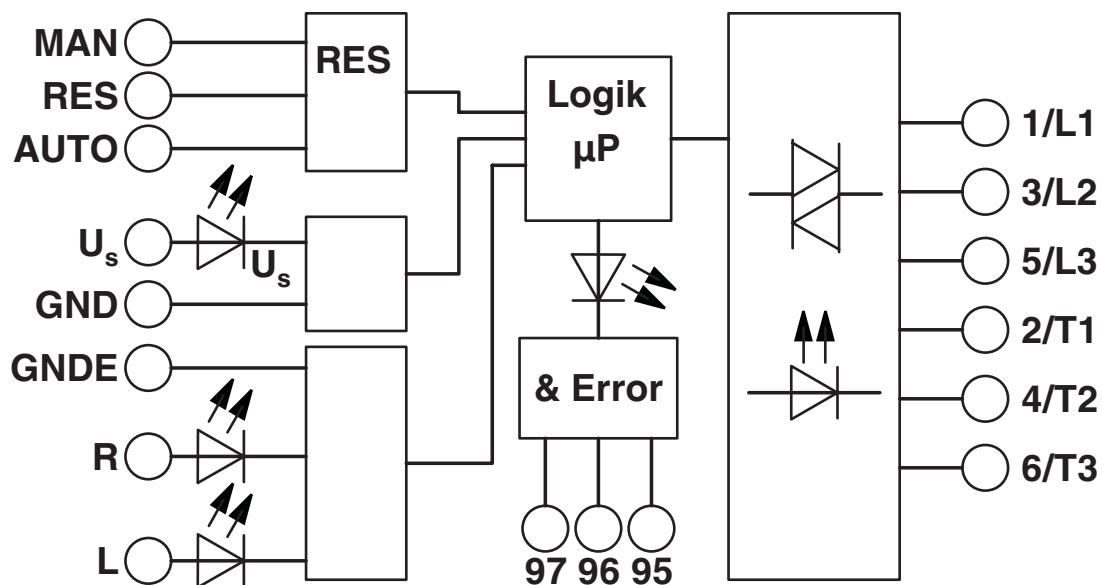

ELR W3- 24DC/500AC- 2I-BR - Hybrid motor starter



2297109

<https://www.phoenixcontact.com/us/products/2297109>

Approvals

To download certificates, visit the product detail page: <https://www.phoenixcontact.com/us/products/2297109>



EAC

Approval ID: RU*C-DE.*08.B.00520*



CCC

Approval ID: 2016010304871315

ELR W3- 24DC/500AC- 2I-BR - Hybrid motor starter



2297109

<https://www.phoenixcontact.com/us/products/2297109>

Classifications

ECLASS

ECLASS-13.0	27370905
ECLASS-15.0	27370905

ETIM

ETIM 10.0	EC001037
-----------	----------

UNSPSC

UNSPSC 21.0	25173900
-------------	----------

2297109

<https://www.phoenixcontact.com/us/products/2297109>

Environmental product compliance

EU RoHS

Fulfills EU RoHS substance requirements	Yes
Exemption	7(a), 7(c)-I

China RoHS

Environment friendly use period (EFUP)	EFUP-50
	An article-related China RoHS declaration table can be found in the download area for the respective article under "Manufacturer declaration". For all articles with EFUP-E, no China RoHS declaration table issued and required.

EU REACH SVHC

REACH candidate substance (CAS No.)	1-Methyl-2-pyrrolidone (NMP)(CAS: 872-50-4)
	Lead(CAS: 7439-92-1)
	2,2',6,6'-tetrabromo-4,4'-isopropylidenediphenol(CAS: 79-94-7)
SCIP	691b943a-eeec-4213-a48f-3ca24220efc4

Phoenix Contact 2026 © - all rights reserved
<https://www.phoenixcontact.com>

Phoenix Contact USA
 586 Fulling Mill Road
 Middletown, PA 17057, United States
 (+717) 944-1300
info@phoenixcon.com