

HCS-C MINI 1W 9V 1 C 7035 - Electronics housing



2203150

<https://www.phoenixcontact.com/us/products/2203150>

Please be informed that the data shown in this PDF document is generated from our online catalog. Please find the complete data in the user documentation. Our general terms of use for downloads are valid.



Handheld housing, C-Mini, light gray, consisting of two half shells, front plate above, screws. Front 1.1 mm recessed, with window and keypad slot, battery compartment cover and battery contacts for 9 V battery

Your advantages

- Suitable for handheld devices
- Easy integration of LCD displays and membrane keypads
- Ergonomic straight or staggered housing design
- Fast mounting, thanks to the modular design

Commercial data

Item number	2203150
Packing unit	1 pc
Minimum order quantity	1 pc
Sales key	AC02
Product key	ACFACA
GTIN	4055626377032
Weight per piece (including packing)	100 g
Weight per piece (excluding packing)	100 g
Customs tariff number	84879090
Country of origin	DE

2203150

<https://www.phoenixcontact.com/us/products/2203150>

Technical data

Product properties

Product type	Complete housing
Housing type	Handheld housing
Housing type	Handheld housing
Housing series	HCS
Ventilation openings present	no
Battery compartment	9 V

Display

Diagonal	2 in. / 5 cm (Window for display)
----------	-----------------------------------

Dimensions

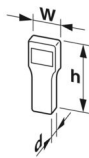
Dimensional drawing	
Width	70.5 mm
Height	110 mm
Depth	26 mm
Dimensions	60.5 mm x 100 mm x 1.1 mm (Recessed area on front) 46 mm x 25.4 mm (Window for display) 27.4 mm x 3.2 mm (Opening for the membrane keypad cable) 50 mm x 29.4 mm x 1.2 mm (Holder for cover lens)
Front with faceplate	top, 1 x (49.8 mm x 17.8 mm)

PCB design

PCB thickness	1.4 mm ... 1.8 mm
---------------	-------------------

Material specifications

Color (Housing)	light gray (RAL 7035)
Material Housing	ABS
Flammability rating according to UL 94	V0
CTI according to IEC 60112	400 ≤ CTI < 600

Environmental and real-life conditions

Glow-wire test

Specification	IEC 60695-2-11:2014-02
Temperature	850 °C
Time of exposure	30 s

Thermal stability / ball thrust test

HCS-C MINI 1W 9V 1 C 7035 - Electronics housing



2203150

<https://www.phoenixcontact.com/us/products/2203150>

Specification	IEC 60695-10-2:2014-02
Temperature	80 °C
Test duration	1 h
Force	20

Ambient conditions

Max. IP code to attain	IP40
Ambient temperature (operation)	-40 °C ... 80 °C (depending on power dissipation)
Ambient temperature (storage/transport)	-40 °C ... 55 °C
Ambient temperature (assembly)	-5 °C ... 80 °C
Relative humidity (storage/transport)	95 %

PCB data

Number of PCB holders	2
Thickness of the PCB	1.4 mm ... 1.8 mm

Mounting

Tightening torque / speed	Screw connection between housing halves: 0.25 - 0.3 Nm / 500 - 1000 rpm
Tightening torque	0.25 Nm ... 0.3 Nm

2203150

<https://www.phoenixcontact.com/us/products/2203150>

Drawings

Dimensional drawing

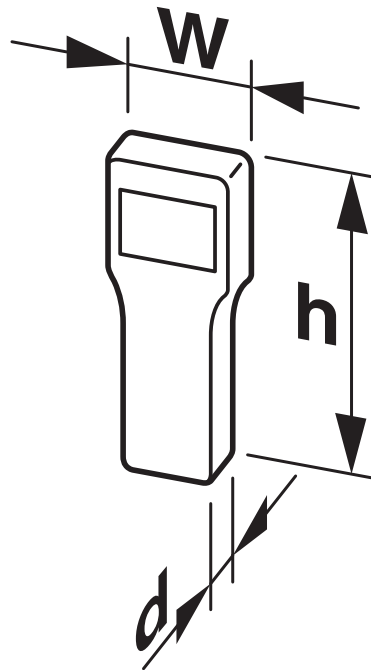

Schematic representation – for additional information, see product range drawing in the Download Center

2203150

<https://www.phoenixcontact.com/us/products/2203150>

Classifications

ECLASS

ECLASS-13.0	27190102
ECLASS-15.0	27190102

ETIM

ETIM 9.0	EC001031
----------	----------

UNSPSC

UNSPSC 21.0	31261500
-------------	----------

HCS-C MINI 1W 9V 1 C 7035 - Electronics housing



2203150

<https://www.phoenixcontact.com/us/products/2203150>

Environmental product compliance

EU RoHS

Fulfills EU RoHS substance requirements	Yes, No exemptions
---	--------------------

China RoHS

Environment friendly use period (EFUP)	EFUP-E
	No hazardous substances above the limits

EU REACH SVHC

REACH candidate substance (CAS No.)	No substance above 0.1 wt%
-------------------------------------	----------------------------

Phoenix Contact 2026 © - all rights reserved
<https://www.phoenixcontact.com>

Phoenix Contact USA
586 Fulling Mill Road
Middletown, PA 17057, United States
(+717) 944-1300
info@phoenixcon.com