

# UHV 50-AS/AS - High-current connector



2130017

<https://www.phoenixcontact.com/us/products/2130017>

Please be informed that the data shown in this PDF document is generated from our online catalog. Please find the complete data in the user documentation. Our general terms of use for downloads are valid.

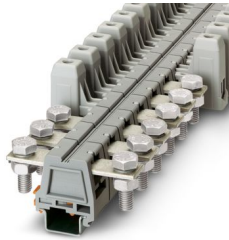

High-current connector with bolt connection, cross section: 25 mm<sup>2</sup> ... 50 mm<sup>2</sup>, AWG: 6 ... 1/0, width: 32 mm, color: gray

The figure shows a combination of versions UHV 50-AS/AS, UHV 50-KH/AS and UHV 50-KH/KH

## Your advantages

- The comprehensive range of accessories, such as the connection rail for cross connection, ensures safe and user-friendly wiring of conductors up to 240 mm<sup>2</sup>
- Versions are available with a cable lug or direct connection and there is a mixed version of both connection methods
- The UHV ... high-current connectors are available in several versions

## Commercial data

Item number	2130017
Packing unit	1 pc
Note	Made to order (non-returnable)
Sales key	BE04
Product key	BE4112
GTIN	4017918052799
Weight per piece (including packing)	165.96 g
Weight per piece (excluding packing)	165.96 g
Customs tariff number	85369010
Country of origin	IN

# UHV 50-AS/AS - High-current connector



2130017

<https://www.phoenixcontact.com/us/products/2130017>

## Technical data

### Product properties

Product type	Bolt connection terminal block
Number of connections	2
Number of rows	1
Potentials	1

### Insulation characteristics

Overvoltage category	III
Degree of pollution	3

### Electrical properties

Rated surge voltage	8 kV
---------------------	------

### Connection data

Number of connections per level	2
Nominal cross section	50 mm <sup>2</sup>

#### 1 level

Connection method	Bolt connection
Stripping length	The stripping length depends on the specification provided by the cable lug manufacturer.
Busbar	20 mm x 3 mm
Connection in acc. with standard	IEC 60947-7-1
Nominal cross section	50 mm <sup>2</sup>
Nominal current	150 A
Maximum load current	150 A (with 50 mm <sup>2</sup> conductor cross-section)
Nominal voltage	1000 V

#### Cable lug connection DIN 46234:1980-03

Connection in acc. with standard	DIN 46234:1980-03
Cross section	6 mm <sup>2</sup> ... 50 mm <sup>2</sup>
Cross section range AWG	(converted acc. to IEC)
Hole diameter	10.5 mm
Width	18 mm
Bolt diameter	10 mm
Screw thread	M10
Tightening torque	25 ... 30 Nm
Identification color of ring cable lugs : yellow	6 mm <sup>2</sup>
Connection in acc. with standard	DIN 46235:1983-07
Cross section	16 mm <sup>2</sup> ... 50 mm <sup>2</sup>
Cross section range AWG	(converted acc. to IEC)
Hole diameter	10.5 mm
Width	22 mm

# UHV 50-AS/AS - High-current connector

2130017

<https://www.phoenixcontact.com/us/products/2130017>

Bolt diameter	10 mm
Screw thread	M10
Tightening torque	25 ... 30 Nm
Connection in acc. with standard	DIN 46237:1970-07
Cross section	6 mm <sup>2</sup> ... 6 mm <sup>2</sup>
Cross section range AWG	(converted acc. to IEC)
Hole diameter	10.5 mm
Bolt diameter	10 mm
Screw thread	M10
Tightening torque	25 ... 30 Nm

## Dimensions

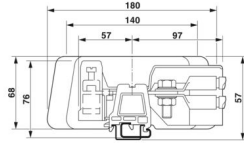
Dimensional drawing	
Width	32 mm

## Material specifications

Color	gray
Flammability rating according to UL 94	V0
Insulating material group	II
Insulating material	PA
Temperature index of insulation material (DIN EN 60216-1 (VDE 0304-21))	125 °C
Relative insulation material temperature index (Elec., UL 746 B)	125 °C

## Electrical tests

### Surge voltage test

Result	Test passed
Result	Test passed

### Power-frequency withstand voltage

Test voltage setpoint	2.2 kV
Result	Test passed

## Mechanical properties

### Mechanical data

Open side panel	No
-----------------	----

## Mechanical tests

### Mechanical strength

Result	Test passed
--------	-------------

# UHV 50-AS/AS - High-current connector



2130017

<https://www.phoenixcontact.com/us/products/2130017>

## Attachment on the carrier

DIN rail/fixing support	NS 32/NS 35
Result	Test passed

## Environmental and real-life conditions

### Needle-flame test

Time of exposure	30 s
Result	Test passed

### Oscillation/broadband noise

Specification	DIN EN 50155 (VDE 0115-200):2008-03
Spectrum	Long life test category 2, bogie-mounted
Frequency	$f_1 = 5 \text{ Hz}$ to $f_2 = 250 \text{ Hz}$
ASD level	$6.12 \text{ (m/s}^2\text{)}^2\text{/Hz}$
Acceleration	3.12g
Test duration per axis	5 h
Test directions	X-, Y- and Z-axis

### Shocks

Pulse shape	Semi-sinusoidal
Acceleration	30g
Shock duration	18 ms
Number of shocks per direction	3
Test directions	X-, Y- and Z-axis (pos. and neg.)

### Ambient conditions

Ambient temperature (operation)	-60 °C ... 85 °C
Ambient temperature (storage/transport)	-25 °C ... 55 °C (for a short time, not exceeding 24 h, -60 °C to +70 °C)
Ambient temperature (assembly)	-5 °C ... 70 °C
Ambient temperature (actuation)	-5 °C ... 70 °C
Permissible humidity (storage/transport)	30 % ... 70 %

## Standards and regulations

Connection in acc. with standard	IEC 60947-7-1
----------------------------------	---------------

## Mounting

Mounting type	NS 35/15
---------------	----------

# UHV 50-AS/AS - High-current connector

2130017

<https://www.phoenixcontact.com/us/products/2130017>

## Drawings

Dimensional drawing

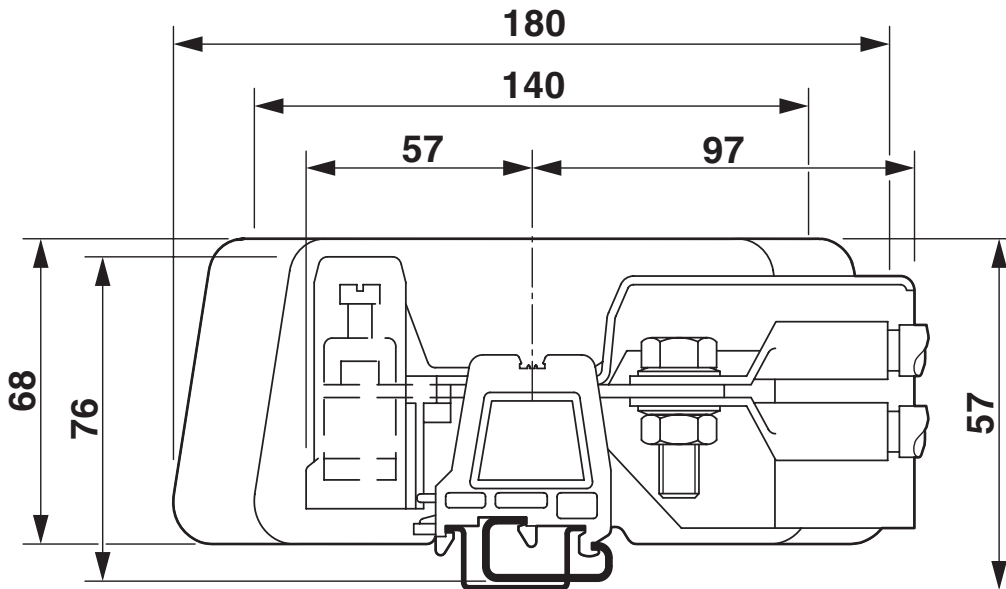

Dimensional drawing

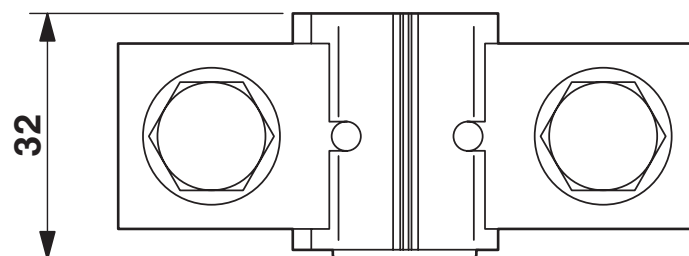
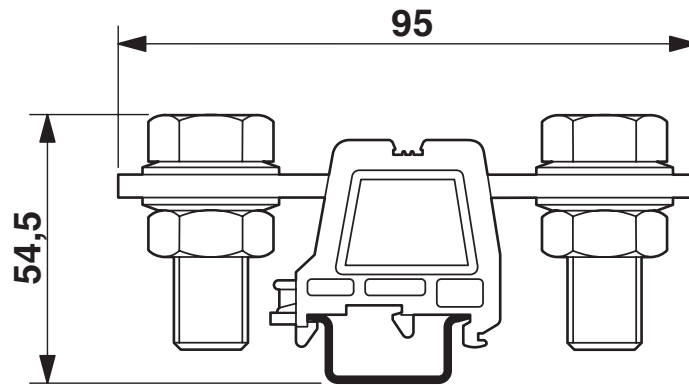

# UHV 50-AS/AS - High-current connector

2130017

<https://www.phoenixcontact.com/us/products/2130017>

Schematic diagram

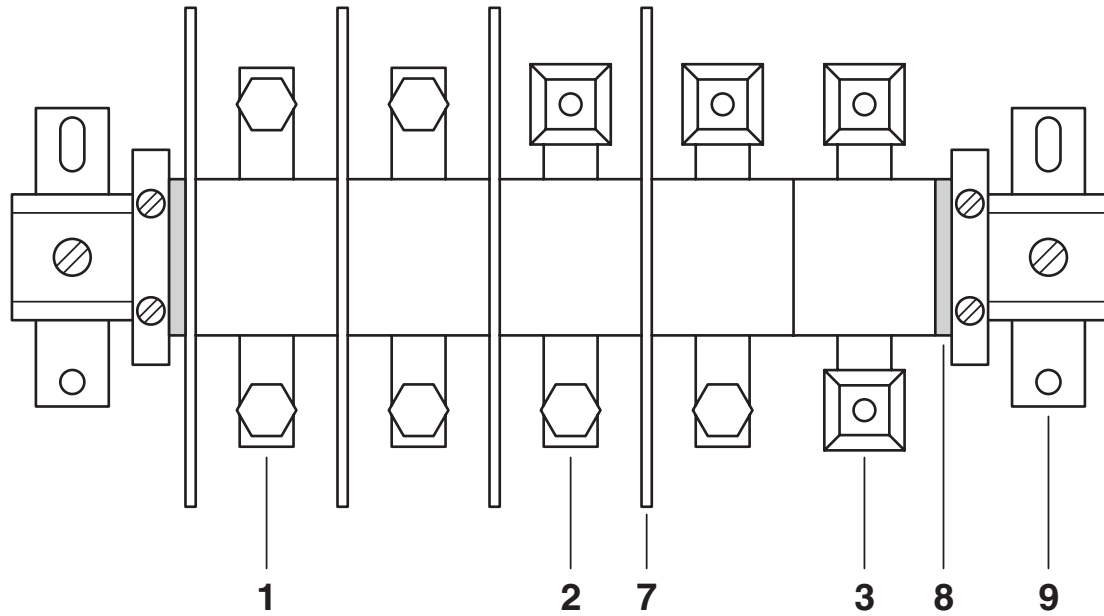

- 1 = high current connector, AS screw set on both sides
- 2 = high current connector, terminal sleeve KH on one side, screw set AS on the other side
- 3 = high current connector, terminal sleeves KH on both sides, for direct cable connection
- 7 = separating plate
- 8 = end piece
- 9 = flat bracket

Circuit diagram



# UHV 50-AS/AS - High-current connector



2130017

<https://www.phoenixcontact.com/us/products/2130017>

## Classifications

### UNSPSC

UNSPSC 21.0	39121410
-------------	----------

# UHV 50-AS/AS - High-current connector



2130017

<https://www.phoenixcontact.com/us/products/2130017>

## Environmental product compliance

### EU RoHS

Fulfills EU RoHS substance requirements	Yes, No exemptions
---	--------------------

### China RoHS

Environment friendly use period (EFUP)	EFUP-E
	No hazardous substances above the limits

### EU REACH SVHC

REACH candidate substance (CAS No.)	No substance above 0.1 wt%
-------------------------------------	----------------------------

Phoenix Contact 2026 © - all rights reserved  
<https://www.phoenixcontact.com>

Phoenix Contact USA  
586 Fulling Mill Road  
Middletown, PA 17057, United States  
(+717) 944-1300  
[info@phoenixcon.com](mailto:info@phoenixcon.com)