

VC-D SOC 1,5-2,5 ATE - Crimp contact



1884131

<https://www.phoenixcontact.com/us/products/1884131>

Please be informed that the data shown in this PDF document is generated from our online catalog. Please find the complete data in the user documentation. Our general terms of use for downloads are valid.

Rolled female contact, single contacts, silver-plated, 1.5 mm² ... 2.5 mm²



Commercial data

Item number	1884131
Packing unit	1 pc
Note	Made to order (non-returnable)
Sales key	BF65
Product key	AF7AIB
GTIN	4017918163839
Weight per piece (including packing)	490 g
Weight per piece (excluding packing)	490 g
Customs tariff number	85366990
Country of origin	DE

VC-D SOC 1,5-2,5 ATE - Crimp contact



1884131

<https://www.phoenixcontact.com/us/products/1884131>

Technical data

Product properties

Product type	Crimp contact
Series	VC-D...R
	HC-D...R
Contact material type	rolled

Connection data

Connection technology

Contact connection type	Socket
-------------------------	--------

Mechanical properties

Mechanical data

Insertion/withdrawal cycles	≥ 500
-----------------------------	-------

Environmental and real-life conditions

Ambient conditions

Ambient temperature (operation)	-40 °C ... 125 °C
---------------------------------	-------------------

VC-D SOC 1,5-2,5 ATE - Crimp contact



1884131

<https://www.phoenixcontact.com/us/products/1884131>

Drawings

Dimensional drawing

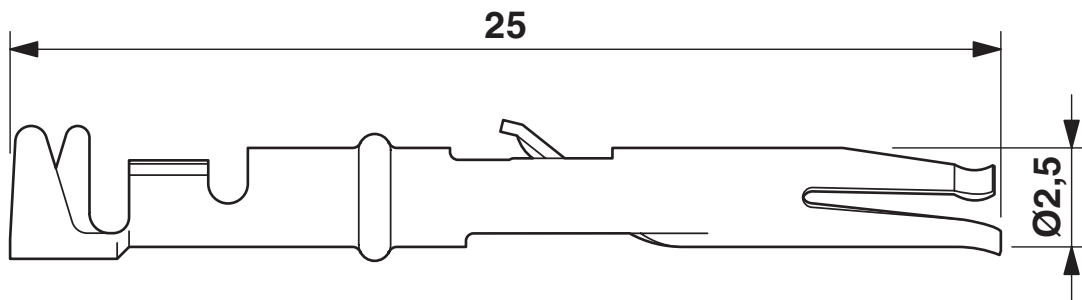

VC-D SOC 1,5-2,5 ATE - Crimp contact



1884131

<https://www.phoenixcontact.com/us/products/1884131>

Classifications

ECLASS

ECLASS-13.0	27440204
ECLASS-15.0	27440204

UNSPSC

UNSPSC 21.0	39121522
-------------	----------

VC-D SOC 1,5-2,5 ATE - Crimp contact



1884131

<https://www.phoenixcontact.com/us/products/1884131>

Environmental product compliance

EU RoHS

Fulfills EU RoHS substance requirements	Yes, No exemptions
---	--------------------

China RoHS

Environment friendly use period (EFUP)	EFUP-E
	No hazardous substances above the limits

EU REACH SVHC

REACH candidate substance (CAS No.)	No substance above 0.1 wt%
-------------------------------------	----------------------------

Phoenix Contact 2026 © - all rights reserved
<https://www.phoenixcontact.com>

Phoenix Contact USA
586 Fulling Mill Road
Middletown, PA 17057, United States
(+717) 944-1300
info@phoenixcon.com