

PSC 1,5/ 3-M - PCB header

1841857

<https://www.phoenixcontact.com/us/products/1841857>

Please be informed that the data shown in this PDF document is generated from our online catalog. Please find the complete data in the user documentation. Our general terms of use for downloads are valid.



PCB headers, nominal cross section: 1.5 mm², color: green, nominal current: 8 A, rated voltage (III/2): 320 V, contact surface: Sn, contact connection type: Pin, number of potentials: 3, number of rows: 1, number of positions: 3, number of connections: 3, product range: PSC 1,5/..-M, pitch: 3.5 mm, mounting: Wave soldering, pin layout: Zigzag pinning W, solder pin [P]: 3.5 mm, number of solder pins per potential: 1, plug-in system: PSC 1,5, Electrical properties: shielded, Pin connector pattern alignment: Standard, locking: Screw locking mechanism, mounting method: Threaded flange, type of packaging: packed in cardboard

Your advantages

- Well-known connection principle allows worldwide use
- Shroud for professional EMC shield feed-through on the inside of the device
- Screwable flange for superior mechanical stability

Commercial data

Item number	1841857
Packing unit	50 pc
Minimum order quantity	50 pc
Sales key	AA02
Product key	AABWPB
GTIN	4017918111861
Weight per piece (including packing)	6.922 g
Weight per piece (excluding packing)	6.4 g
Customs tariff number	85366930
Country of origin	PL

PSC 1,5/ 3-M - PCB header



1841857

<https://www.phoenixcontact.com/us/products/1841857>

Technical data

Product properties

Product type	PCB headers
Product family	PSC 1,5/..-M
Product line	COMBICON Connectors S
Type	Headers with shielding
Number of positions	3
Pitch	3.5 mm
Number of connections	3
Number of rows	1
Number of potentials	3
Mounting type	without
Pin layout	Zigzag pinning W
Solder pins per potential	1
Electrical characteristic	shielded

Electrical properties

Properties

Nominal current I_N	8 A
Nominal voltage U_N	320 V
Rated voltage (III/3)	250 V
Rated surge voltage (III/3)	4 kV
Rated voltage (III/2)	320 V
Rated surge voltage (III/2)	4 kV
Rated voltage (II/2)	630 V
Rated surge voltage (II/2)	4 kV
Electrical characteristic	shielded

Mounting

Mounting type	Wave soldering
Pin layout	Zigzag pinning W

Material specifications

Material data - contact

Note	WEEE/RoHS-compliant, free of whiskers according to IEC 60068-2-82/JEDEC JESD 201
Contact material	Cu alloy
Surface characteristics	Tin-plated
Metal surface contact area (top layer)	Tin (5 μm - 7 μm Sn)
Metal surface contact area (middle layer)	Nickel (2 μm - 3 μm Ni)
Metal surface soldering area (top layer)	Tin (5 μm - 7 μm Sn)
Metal surface soldering area (middle layer)	Nickel (2 μm - 3 μm Ni)

PSC 1,5/ 3-M - PCB header

1841857

<https://www.phoenixcontact.com/us/products/1841857>

Material data - housing

Color (Housing)	green (6021)
Insulating material	PA
Insulating material group	I
CTI according to IEC 60112	600
Flammability rating according to UL 94	V0
Glow wire flammability index GWFI according to EN 60695-2-12	850
Glow wire ignition temperature GWIT according to EN 60695-2-13	775
Temperature for the ball pressure test according to EN 60695-10-2	125 °C

Dimensions

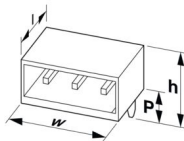
Dimensional drawing	
Pitch	3.5 mm
Width [w]	32.1 mm
Height [h]	17.15 mm
Length [l]	20.85 mm
Installed height	13.65 mm
Solder pin length [P]	3.5 mm

PCB design

Hole diameter	1.2 mm
---------------	--------

Electrical tests

Air clearances and creepage distances |

Insulating material group	I
Rated insulation voltage (III/3)	250 V
Rated surge voltage (III/3)	4 kV
Rated insulation voltage (III/2)	320 V
Rated surge voltage (III/2)	4 kV
Rated insulation voltage (II/2)	630 V
Rated surge voltage (II/2)	4 kV

Environmental and real-life conditions

Ambient conditions

Ambient temperature (storage/transport)	-40 °C ... 70 °C
Relative humidity (storage/transport)	30 % ... 70 %
Ambient temperature (assembly)	-5 °C ... 100 °C

PSC 1,5/ 3-M - PCB header



1841857

<https://www.phoenixcontact.com/us/products/1841857>

Ambient temperature (operation)	-40 °C ... 100 °C (dependent on the derating curve)
---------------------------------	---

Packaging specifications

Type of packaging	packed in cardboard
-------------------	---------------------

PSC 1,5/ 3-M - PCB header

1841857

<https://www.phoenixcontact.com/us/products/1841857>

Drawings

Dimensional drawing

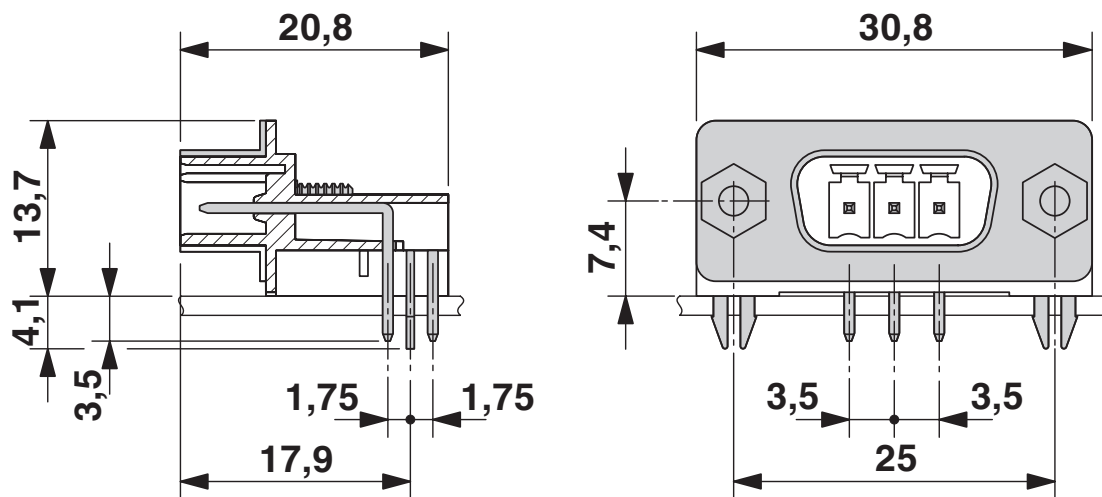

Dimensional drawing

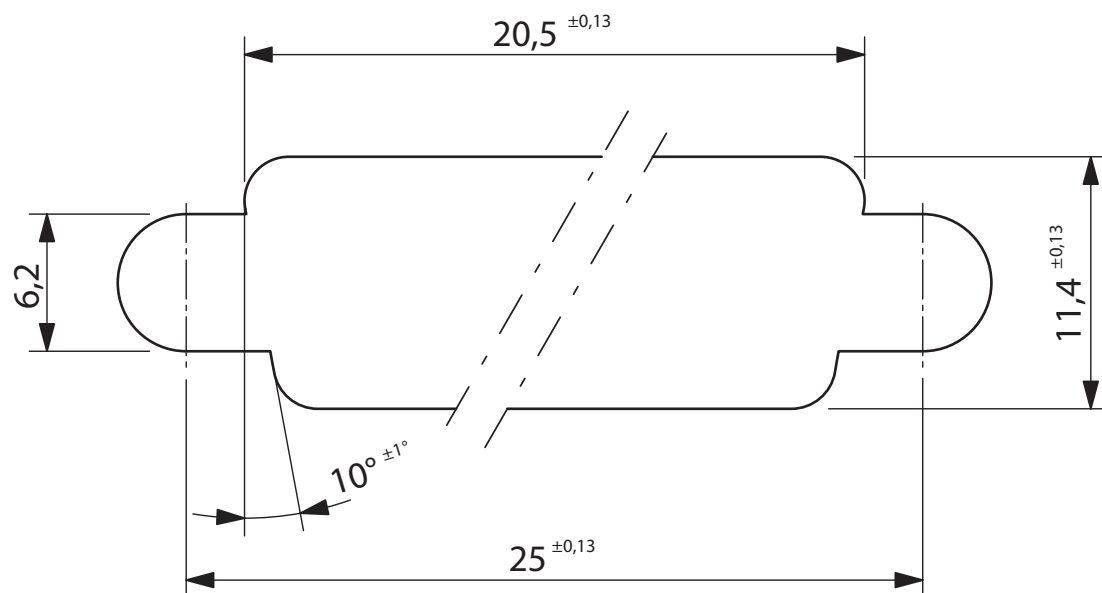

Panel cutout in acc. with DIN 41652-3 for walls up to 4.5 mm thick

PSC 1,5/ 3-M - PCB header

1841857

<https://www.phoenixcontact.com/us/products/1841857>

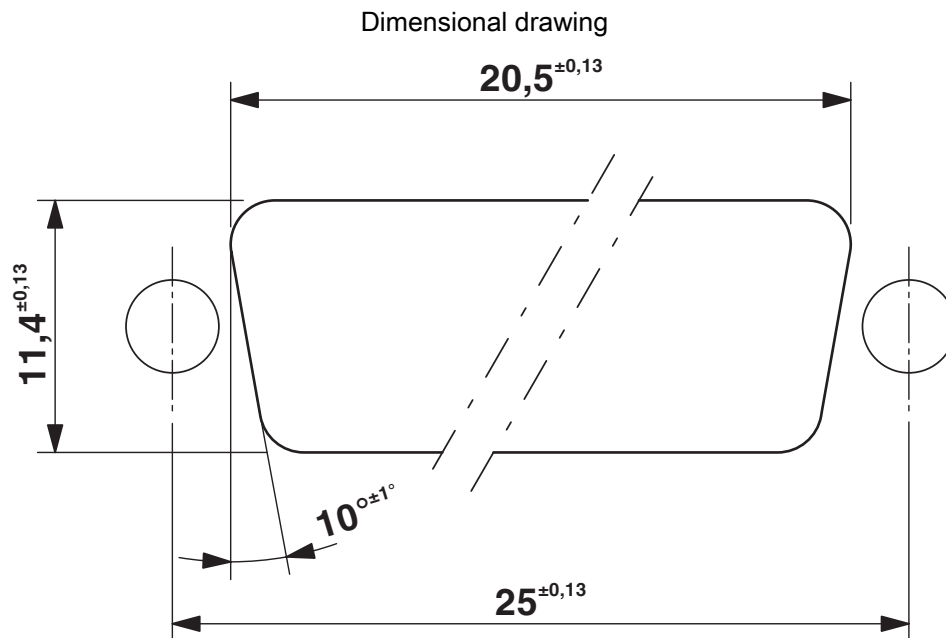

Panel cutout in acc. with DIN 41652-3 for wall up to 2.0 mm thick

Schematic diagram

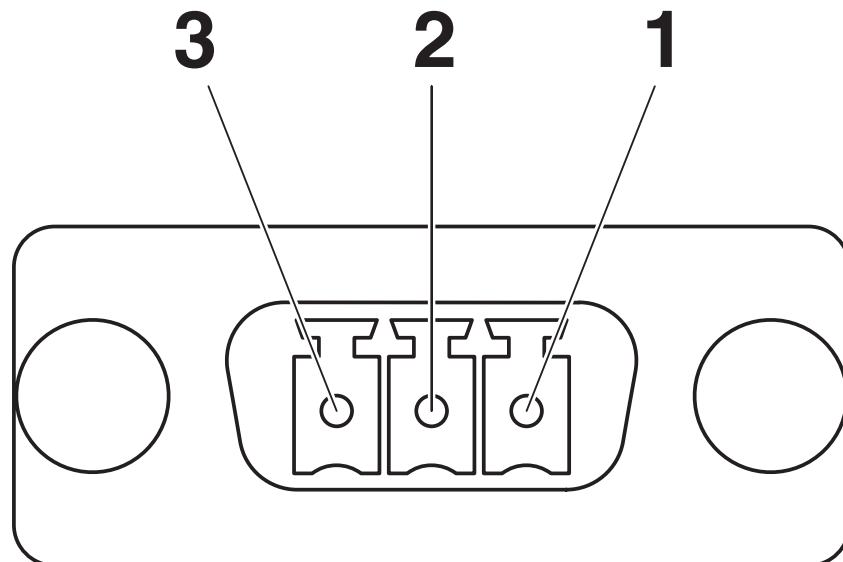

PSC 1,5/ 3-M - PCB header

1841857

<https://www.phoenixcontact.com/us/products/1841857>

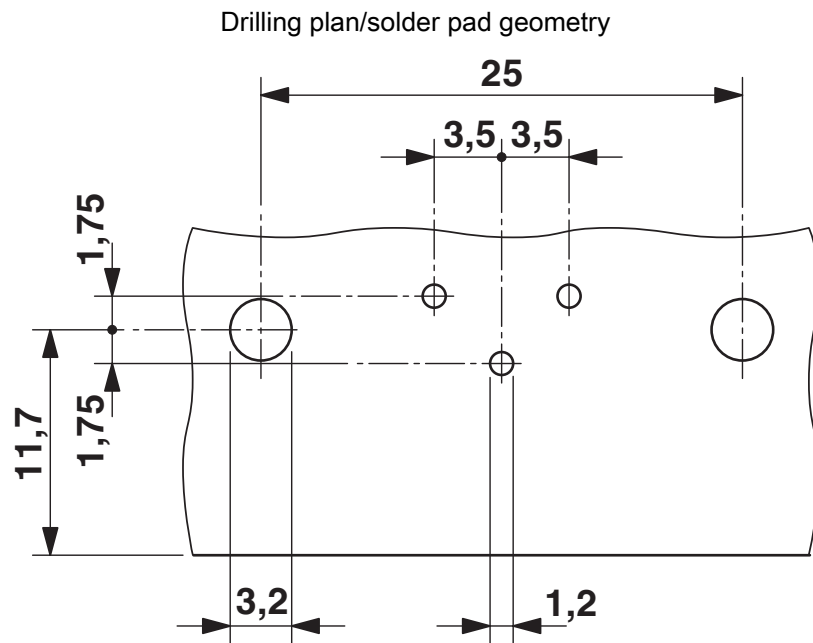

PSC 1,5/ 3-M - PCB header





1841857

<https://www.phoenixcontact.com/us/products/1841857>

Approvals

To download certificates, visit the product detail page: <https://www.phoenixcontact.com/us/products/1841857>

 CSA Approval ID: 13631				
	Nominal voltage U_N	Nominal current I_N	Cross section AWG	Cross section mm^2
B	300 V	8 A	-	-
D	300 V	8 A	-	-

 cULus Recognized Approval ID: E60425-19920306				
	Nominal voltage U_N	Nominal current I_N	Cross section AWG	Cross section mm^2
B	300 V	8 A	-	-
D	300 V	8 A	-	-

PSC 1,5/ 3-M - PCB header



1841857

<https://www.phoenixcontact.com/us/products/1841857>

Classifications

ECLASS

ECLASS-13.0	27460201
ECLASS-15.0	27460201

ETIM

ETIM 10.0	EC002637
-----------	----------

UNSPSC

UNSPSC 21.0	39121400
-------------	----------

PSC 1,5/ 3-M - PCB header



1841857

<https://www.phoenixcontact.com/us/products/1841857>

Environmental product compliance

EU RoHS

Fulfills EU RoHS substance requirements	Yes
Exemption	6(c)

China RoHS

Environment friendly use period (EFUP)	EFUP-50
	An article-related China RoHS declaration table can be found in the download area for the respective article under "Manufacturer declaration". For all articles with EFUP-E, no China RoHS declaration table issued and required.

EU REACH SVHC

REACH candidate substance (CAS No.)	Lead(CAS: 7439-92-1)
SCIP	6d963c8f-3561-4f1d-9ffe-327adc4c85d3

EF3.1 Climate Change

CO2e kg	0.12 kg CO2e
---------	--------------

Phoenix Contact 2026 © - all rights reserved
<https://www.phoenixcontact.com>

Phoenix Contact USA
586 Fulling Mill Road
Middletown, PA 17057, United States
(+717) 944-1300
info@phoenixcon.com