

# PLA 5/11-7,5-ZF - PCB terminal block

1792313

<https://www.phoenixcontact.com/us/products/1792313>

Please be informed that the data shown in this PDF document is generated from our online catalog. Please find the complete data in the user documentation. Our general terms of use for downloads are valid.



The figure shows a 4-pos. version of the product

PCB terminal block, nominal current: 41 A, rated voltage (III/2): 1000 V, nominal cross section: 6 mm<sup>2</sup>, number of potentials: 11, number of rows: 1, number of positions per row: 11, product range: PLA 5/, pitch: 7.5 mm, connection method: Push-lock spring connection, mounting: Wave soldering, conductor/PCB connection direction: 30 °, color: green, Pin layout: Zigzag pinning M, Solder pin [P]: 3.6 mm, number of solder pins per potential: 1, type of packaging: packed in cardboard

## Your advantages

- Tool-free lever principle enables time-saving connection and release of conductors with/without ferrules
- Defined contact force ensures that contact remains stable over the long term
- Time-saving push-in connection when lever is closed
- Unrestricted 600-V-UL approval thanks to compact zig-zag pinning
- Quick and convenient testing using integrated test option

## Commercial data

Item number	1792313
Packing unit	1 pc
Note	Made to order (non-returnable)
Sales key	AA14
Product key	AANTAA
GTIN	4046356610605
Weight per piece (including packing)	47.312 g
Weight per piece (excluding packing)	47.272 g
Customs tariff number	85369010
Country of origin	SK

# PLA 5/11-7,5-ZF - PCB terminal block



1792313

<https://www.phoenixcontact.com/us/products/1792313>

## Technical data

### Product properties

Product type	PCB terminal block
Product family	PLA 5/
Product line	COMBICON Terminals L
Number of positions	11
Pitch	7.5 mm
Number of connections	11
Number of rows	1
Number of potentials	11
Pin layout	Zigzag pinning M
Solder pins per potential	1

### Electrical properties

#### Properties

Nominal current $I_N$	41 A
Nominal voltage $U_N$	1000 V
Rated voltage (III/3)	1000 V
Rated surge voltage (III/3)	8 kV
Rated voltage (III/2)	1000 V
Rated surge voltage (III/2)	8 kV
Rated voltage (II/2)	1000 V
Rated surge voltage (II/2)	6 kV

### Connection data

#### Connection technology

Nominal cross section	6 mm <sup>2</sup>
-----------------------	-------------------

#### Conductor connection

Connection method	Push-lock spring connection
Conductor cross-section rigid	0.2 mm <sup>2</sup> ... 6 mm <sup>2</sup>
Conductor cross-section flexible	0.2 mm <sup>2</sup> ... 6 mm <sup>2</sup>
Conductor cross-section AWG	24 ... 10
Conductor cross-section, flexible, with ferrule, without plastic sleeve	0.2 mm <sup>2</sup> ... 6 mm <sup>2</sup>
Conductor cross-section, flexible, with ferrule, with plastic sleeve	0.2 mm <sup>2</sup> ... 6 mm <sup>2</sup>
2 conductors with the same cross section, flexible, with TWIN ferrule with plastic sleeve	0.5 mm <sup>2</sup> ... 2.5 mm <sup>2</sup>
Stripping length	12 mm

### Mounting

Mounting type	Wave soldering
Pin layout	Zigzag pinning M

# PLA 5/11-7,5-ZF - PCB terminal block

1792313

<https://www.phoenixcontact.com/us/products/1792313>

## Material specifications

### Material data - contact

Note	WEEE/RoHS-compliant, free of whiskers according to IEC 60068-2-82/JEDEC JESD 201
Contact material	Cu alloy
Surface characteristics	Tin-plated
Metal surface terminal point (top layer)	Tin (10 µm - 16 µm Sn)
Metal surface soldering area (top layer)	Tin (10 µm - 16 µm Sn)

### Material data - housing

Color (Housing)	green (6021)
Insulating material	PA
Insulating material group	I
CTI according to IEC 60112	600
Flammability rating according to UL 94	V0
Glow wire flammability index GWFI according to EN 60695-2-12	850
Glow wire ignition temperature GWIT according to EN 60695-2-13	775
Temperature for the ball pressure test according to EN 60695-10-2	125 °C

### Material data – actuating element

Insulating material	PA GF
Insulating material group	I
CTI according to IEC 60112	600
Flammability rating according to UL 94	V0

## Dimensions

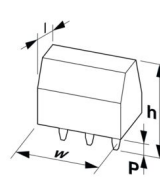
Dimensional drawing	
Pitch	7.5 mm
Width [w]	83.5 mm
Height [h]	32.1 mm
Length [l]	26.4 mm
Installed height	28.5 mm
Solder pin length [P]	3.6 mm
Pin dimensions	1.2 x 1.5 mm

### PCB design

Pin spacing	12.5 mm
Hole diameter	2 mm

1792313

<https://www.phoenixcontact.com/us/products/1792313>

## Mechanical tests

### Connection test

Specification	IEC 60998-2-2:2002-12
Result	Test passed

### Test for conductor damage and slackening

Specification	IEC 60998-2-2:2002-12
Result	Test passed

### Pull-out test

Specification	IEC 60998-2-2:2002-12
Conductor cross-section/conductor type/tractive force setpoint/actual value	0.2 mm <sup>2</sup> / solid / > 10 N
	0.2 mm <sup>2</sup> / flexible / > 10 N
	6 mm <sup>2</sup> / solid / > 80 N
	6 mm <sup>2</sup> / flexible / > 80 N

### Flexion test

Specification	IEC 60998-2-2:2002-12
Result	Test passed

## Electrical tests

### Temperature-rise test

Specification	IEC 60998-2-1:2002-12
Requirement temperature-rise test	Increase in temperature ≤ 45 K

### Insulation resistance

Specification	IEC 60998-1:2002-12
Insulation resistance, neighboring positions	> 5 MΩ

### Air clearances and creepage distances |

Specification	IEC 60664-1:2007-04
Insulating material group	I
Comparative tracking index (IEC 60112)	CTI 600
Rated insulation voltage (III/3)	1000 V
Rated surge voltage (III/3)	8 kV
minimum clearance value - non-homogenous field (III/3)	8 mm
minimum creepage distance (III/3)	12.5 mm
Rated insulation voltage (III/2)	1000 V
Rated surge voltage (III/2)	8 kV
minimum clearance value - non-homogenous field (III/2)	8 mm
minimum creepage distance (III/2)	5 mm
Rated insulation voltage (II/2)	1000 V
Rated surge voltage (II/2)	6 kV
minimum clearance value - non-homogenous field (II/2)	5.5 mm

# PLA 5/11-7,5-ZF - PCB terminal block



1792313

<https://www.phoenixcontact.com/us/products/1792313>

minimum creepage distance (II/2)	5 mm
----------------------------------	------

## Environmental and real-life conditions

### Vibration test

Specification	IEC 60068-2-6:2007-12
Frequency	10 - 150 - 10 Hz
Sweep speed	1 octave/min
Amplitude	0.35 mm (10 Hz ... 60.1 Hz)
Acceleration	5g (60.1 Hz ... 150 Hz)
Test duration per axis	2.5 h
Test directions	X-, Y- and Z-axis

### Glow-wire test

Specification	IEC 60998-1:2002-12
Temperature	850 °C
Time of exposure	5 s

### Ambient conditions

Ambient temperature (storage/transport)	-40 °C ... 70 °C
Relative humidity (storage/transport)	30 % ... 70 %
Ambient temperature (assembly)	-5 °C ... 100 °C
Ambient temperature (operation)	-40 °C ... 100 °C (Depending on the current carrying capacity/derating curve)

## Packaging specifications

Type of packaging	packed in cardboard
-------------------	---------------------

# PLA 5/11-7,5-ZF - PCB terminal block



1792313

<https://www.phoenixcontact.com/us/products/1792313>

## Drawings

Dimensional drawing

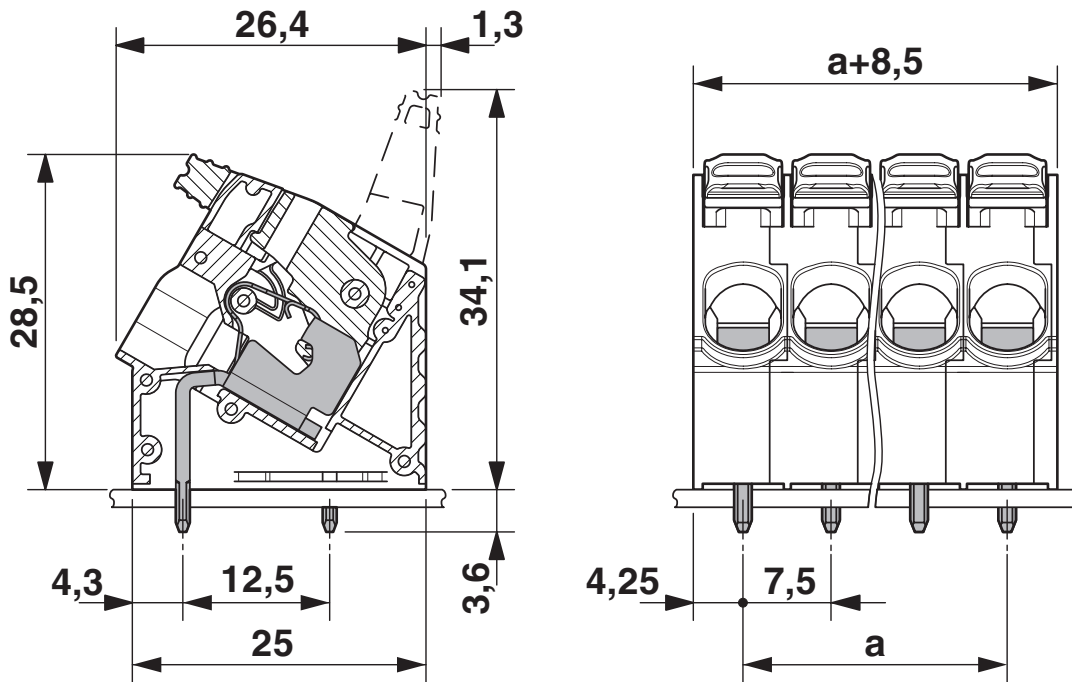

Functional drawing

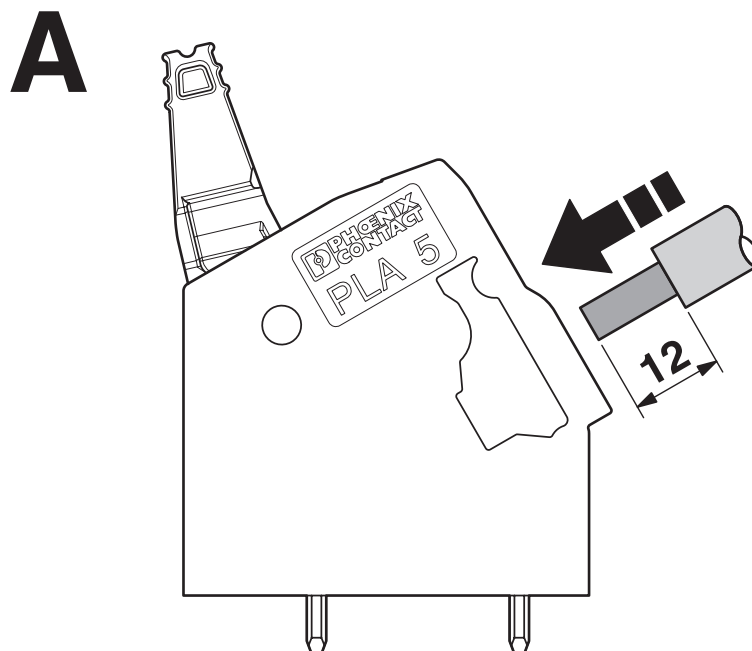

Functional drawing

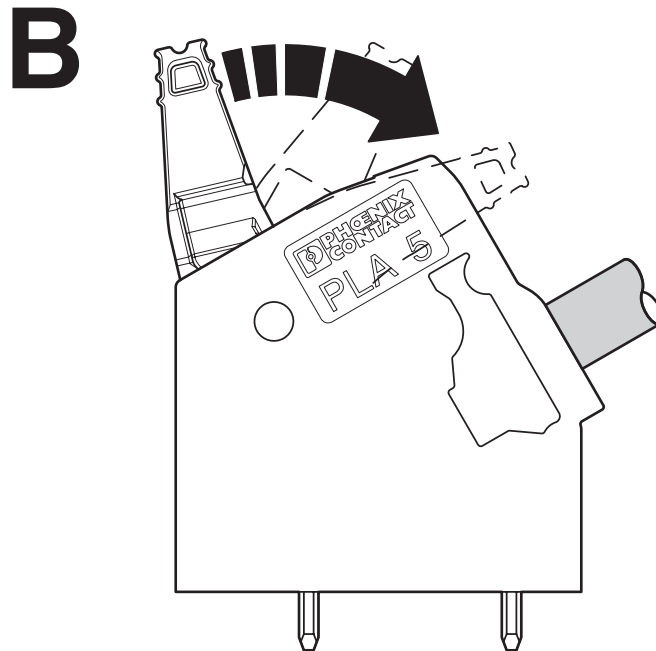

Functional drawing

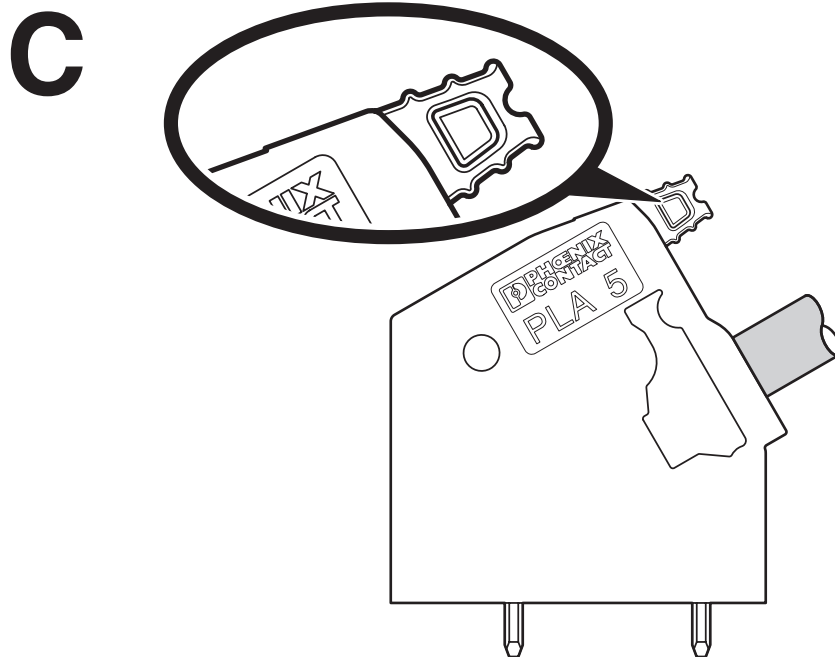

# PLA 5/11-7,5-ZF - PCB terminal block

1792313

<https://www.phoenixcontact.com/us/products/1792313>

Functional drawing

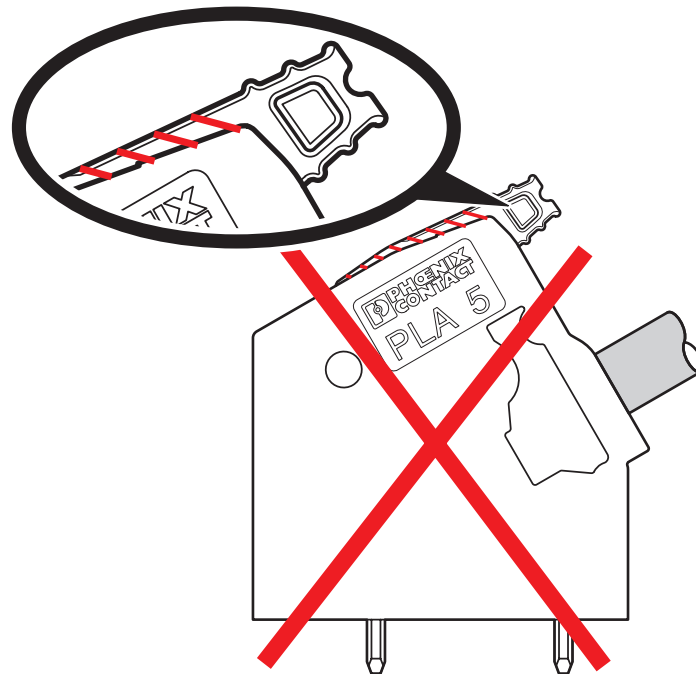

Diagram

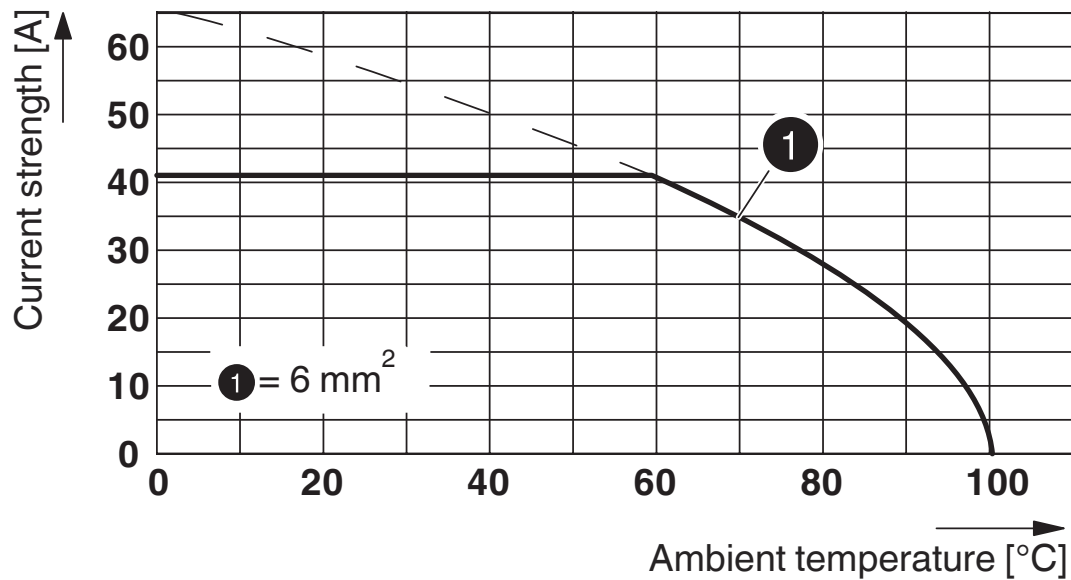

Type: PLA 5/...-7,5-(ZF)

# PLA 5/11-7,5-ZF - PCB terminal block

1792313

<https://www.phoenixcontact.com/us/products/1792313>



Drilling plan/solder pad geometry

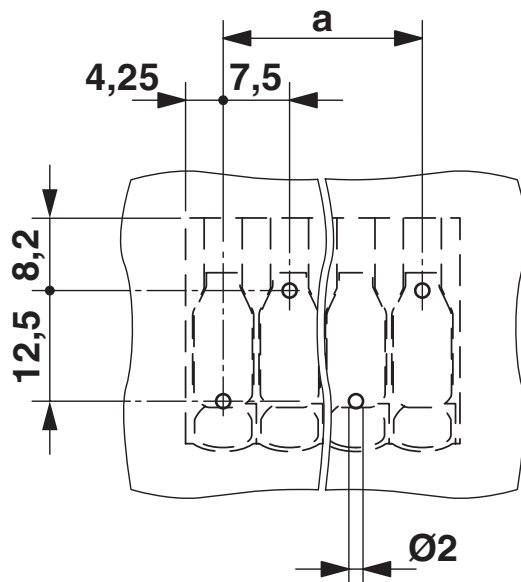

# PLA 5/11-7,5-ZF - PCB terminal block





1792313

<https://www.phoenixcontact.com/us/products/1792313>

## Approvals

To download certificates, visit the product detail page: <https://www.phoenixcontact.com/us/products/1792313>

 <b>cULus Recognized</b> Approval ID: E60425-20110524				
	Nominal voltage $U_N$	Nominal current $I_N$	Cross section AWG	Cross section $\text{mm}^2$
B	600 V	27 A	24 - 10	-
C	600 V	27 A	24 - 10	-

 <b>VDE approval of drawings</b> Approval ID: 40041250				
	Nominal voltage $U_N$	Nominal current $I_N$	Cross section AWG	Cross section $\text{mm}^2$
keine	1000 V	41 A	-	0.2 - 6

# PLA 5/11-7,5-ZF - PCB terminal block



1792313

<https://www.phoenixcontact.com/us/products/1792313>

## Classifications

### ECLASS

ECLASS-13.0

27460101

### ETIM

ETIM 9.0

EC002643

### UNSPSC

UNSPSC 21.0

39121400

# PLA 5/11-7,5-ZF - PCB terminal block



1792313

<https://www.phoenixcontact.com/us/products/1792313>

## Environmental product compliance

### EU RoHS

Fulfills EU RoHS substance requirements	Yes, No exemptions
---	--------------------

### China RoHS

Environment friendly use period (EFUP)	EFUP-E
	No hazardous substances above the limits

### EU REACH SVHC

REACH candidate substance (CAS No.)	No substance above 0.1 wt%
-------------------------------------	----------------------------

Phoenix Contact 2026 © - all rights reserved  
<https://www.phoenixcontact.com>

Phoenix Contact USA  
586 Fulling Mill Road  
Middletown, PA 17057, United States  
(+717) 944-1300  
[info@phoenixcon.com](mailto:info@phoenixcon.com)