

HC-HV 6-AMLD - Housing

1773776

<https://www.phoenixcontact.com/us/products/1773776>

Please be informed that the data shown in this PDF document is generated from our online catalog. Please find the complete data in the user documentation. Our general terms of use for downloads are valid.

HEAVYCON panel mounting base HV6, with single locking latch, height 27 mm, with cover



Commercial data

Item number	1773776
Packing unit	1 pc
Note	Made to order (non-returnable)
Sales key	BF60
Product key	AF7AAB
GTIN	4017918115654
Weight per piece (including packing)	158.14 g
Weight per piece (excluding packing)	158 g
Customs tariff number	85389099
Country of origin	DE

HC-HV 6-AMLD - Housing

1773776

<https://www.phoenixcontact.com/us/products/1773776>



Technical data

Product properties

Product type	Housing with locking latch
Housing type	Panel mounting base
Application	Standard
Type	HV6
Protective cover	yes

Dimensions

Dimensional drawing	
Width	43 mm
Height	27 mm
Length	114 mm

Installation dimensions

Width of the assembly cutout	35 mm
Length of the assembly cutout	86 mm

Material specifications

Seal material	NBR
	CR
Housing material	Die-cast aluminum
Housing surface material	Powder-coated, gray
Material, protective cover	PA
Locking latch material	Stainless steel, handle: PA

Environmental and real-life conditions

Ambient conditions

Degree of protection	IP65
Ambient temperature (operation)	-40 °C ... 125 °C

HC-HV 6-AMLD - Housing

1773776

<https://www.phoenixcontact.com/us/products/1773776>



Drawings

Dimensional drawing

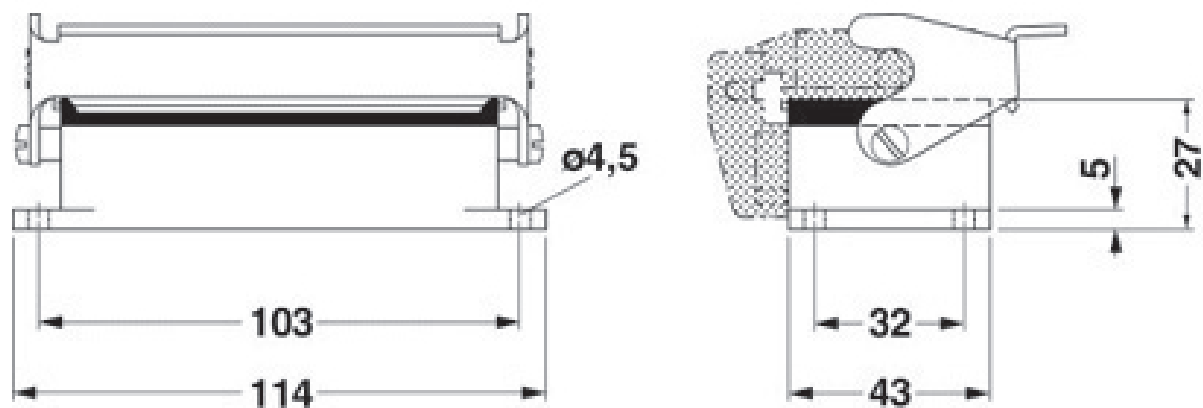

HC-HV 6-AMLD - Housing

1773776

<https://www.phoenixcontact.com/us/products/1773776>



Classifications

ECLASS

ECLASS-13.0	27440202
ECLASS-15.0	27440202

HC-HV 6-AMLD - Housing



1773776

<https://www.phoenixcontact.com/us/products/1773776>

Environmental product compliance

EU RoHS

Fulfills EU RoHS substance requirements	Yes, No exemptions
---	--------------------

China RoHS

Environment friendly use period (EFUP)	EFUP-E
	No hazardous substances above the limits

EU REACH SVHC

REACH candidate substance (CAS No.)	No substance above 0.1 wt%
-------------------------------------	----------------------------

Phoenix Contact 2026 © - all rights reserved
<https://www.phoenixcontact.com>

Phoenix Contact USA
586 Fulling Mill Road
Middletown, PA 17057, United States
(+717) 944-1300
info@phoenixcon.com