

HC-B 24-SMQ-67/M1PG21 - Housing



1771969

<https://www.phoenixcontact.com/us/products/1771969>

Please be informed that the data shown in this PDF document is generated from our online catalog. Please find the complete data in the user documentation. Our general terms of use for downloads are valid.

Box mounting base, with double locking latch, height 67 mm, with screw connection, 1x Pg21



Commercial data

Item number	1771969
Packing unit	1 pc
Note	Made to order (non-returnable)
Sales key	BF55
Product key	AF7AAC
GTIN	4017918036645
Weight per piece (including packing)	424.33 g
Weight per piece (excluding packing)	424.33 g
Customs tariff number	85389099
Country of origin	DE

HC-B 24-SMQ-67/M1PG21 - Housing

1771969

<https://www.phoenixcontact.com/us/products/1771969>

Technical data

Product properties

Product type	Housing with locking latch
Housing type	Surface mounting housing
Application	Standard
Type	B24
No. of cable outlets	1
Type of the screw connection	1x Pg21
Shielded	no
Cable outlet	lateral
Pg screw connection	with

Dimensions

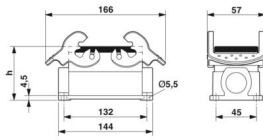
Dimensional drawing	
Width	57 mm
Height	67 mm
Length	144 mm
Wrench size, union nut	28 mm

Material specifications

Material Screw connection	Brass, nickel-plated
Seal material Cable seal	NBR
Housing material	Die-cast aluminum
Housing surface material	Powder-coated, gray
Material, protective cover	PA
Locking latch material	Stainless steel, handle: PA

Mechanical properties

Mechanical data

Type of the screw connection	1x Pg21
Locking type	Latch

Cable/line

External cable diameter Cable 1	10 mm ... 19 mm
---------------------------------	-----------------

Connection data

External cable diameter	10 mm ... 19 mm
-------------------------	-----------------

HC-B 24-SMQ-67/M1PG21 - Housing



1771969

<https://www.phoenixcontact.com/us/products/1771969>

Environmental and real-life conditions

Ambient conditions

Degree of protection	IP65
Ambient temperature (operation)	-40 °C ... 125 °C

HC-B 24-SMQ-67/M1PG21 - Housing



1771969

<https://www.phoenixcontact.com/us/products/1771969>

Drawings

Dimensional drawing

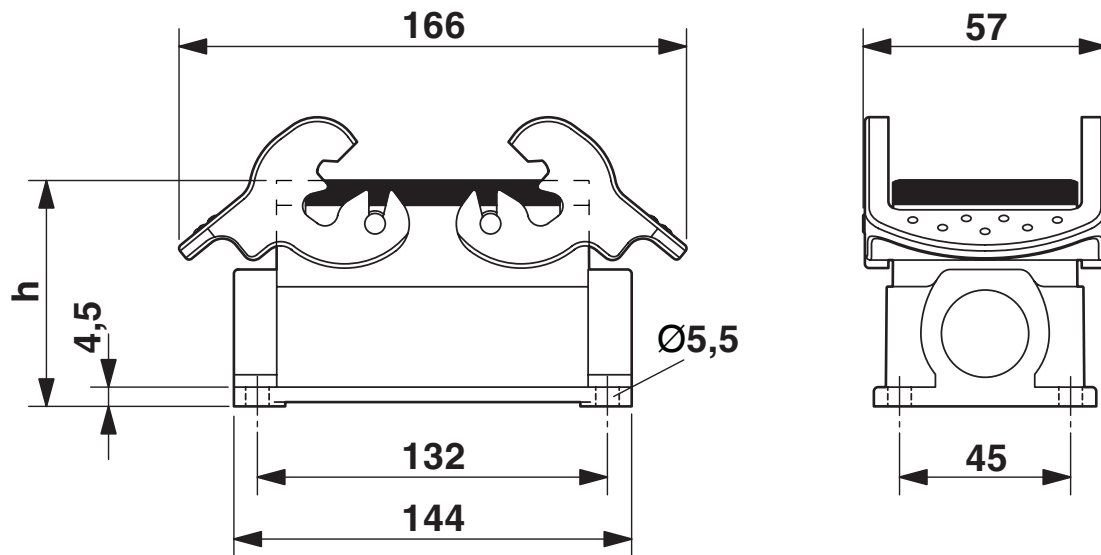

Dimensional drawing

HC-B 24-SMQ-67/M1PG21 - Housing



1771969

<https://www.phoenixcontact.com/us/products/1771969>

Classifications

ECLASS

ECLASS-13.0	27440202
ECLASS-15.0	27440202

UNSPSC

UNSPSC 21.0	31261501
-------------	----------

HC-B 24-SMQ-67/M1PG21 - Housing



1771969

<https://www.phoenixcontact.com/us/products/1771969>

Environmental product compliance

EU RoHS

Fulfills EU RoHS substance requirements	Yes, No exemptions
---	--------------------

China RoHS

Environment friendly use period (EFUP)	EFUP-E
	No hazardous substances above the limits

EU REACH SVHC

REACH candidate substance (CAS No.)	No substance above 0.1 wt%
-------------------------------------	----------------------------

Phoenix Contact 2026 © - all rights reserved
<https://www.phoenixcontact.com>

Phoenix Contact USA
586 Fulling Mill Road
Middletown, PA 17057, United States
(+717) 944-1300
info@phoenixcon.com