

# KDS10 GEHAEUSE HALBSCH. GN - PCB terminal block

1732490

<https://www.phoenixcontact.com/us/products/1732490>

Please be informed that the data shown in this PDF document is generated from our online catalog. Please find the complete data in the user documentation. Our general terms of use for downloads are valid.



The figure shows a 5-pos. version of the product

PCB terminal block, nominal current: 76 A, rated voltage (III/2): 320 V, nominal cross section: 10 mm<sup>2</sup>, number of rows: 1, number of positions per row: 1, product range: Single parts, pitch: 10 mm, connection method: Screw connection with tension sleeve, mounting: Wave soldering, conductor/PCB connection direction: 0 °, color: green, number of solder pins per potential: 4

## Your advantages

- Well-known connection principle allows worldwide use
- Low temperature rise, thanks to maximum contact force
- Allows connection of two conductors
- Potentials can be easily looped through with additional connection to the PCB
- The latching on the side enables various numbers of positions to be combined

## Commercial data

Item number	1732490
Packing unit	50 pc
Minimum order quantity	50 pc
Note	Made to order (non-returnable)
Product key	AANFCA
GTIN	4017918258870
Weight per piece (including packing)	2.15 g
Weight per piece (excluding packing)	2.05 g
Country of origin	DE

# KDS10 GEHAEUSE HALBSCH. GN - PCB terminal block



1732490

<https://www.phoenixcontact.com/us/products/1732490>

## Technical data

### Product properties

Product type	PCB terminal block
Product family	Single parts
Product line	COMBICON Terminals L
Number of positions	1
Pitch	10 mm
Number of rows	1
Solder pins per potential	4

### Electrical properties

#### Properties

Nominal current $I_N$	76 A
Nominal voltage $U_N$	320 V
Rated voltage (III/3)	250 V
Rated surge voltage (III/3)	4 kV
Rated voltage (III/2)	320 V
Rated surge voltage (III/2)	4 kV
Rated voltage (II/2)	630 V
Rated surge voltage (II/2)	4 kV

### Connection data

#### Connection technology

Type	PCB terminal block can be aligned in rows+feed-through terminal block
Nominal cross section	10 mm <sup>2</sup>

#### Conductor connection

Connection method	Screw connection with tension sleeve
Conductor cross-section rigid	0.5 mm <sup>2</sup> ... 16 mm <sup>2</sup>
Conductor cross-section flexible	0.5 mm <sup>2</sup> ... 10 mm <sup>2</sup>
Conductor cross-section AWG	20 ... 6
Conductor cross-section, flexible, with ferrule, without plastic sleeve	0.5 mm <sup>2</sup> ... 10 mm <sup>2</sup>
Conductor cross-section, flexible, with ferrule, with plastic sleeve	0.5 mm <sup>2</sup> ... 10 mm <sup>2</sup>
2 conductors with same cross section, rigid	0.5 mm <sup>2</sup> ... 4 mm <sup>2</sup>
2 conductors with same cross section, flexible	0.5 mm <sup>2</sup> ... 4 mm <sup>2</sup>
2 conductors with same cross section, flexible, with ferrule without plastic sleeve	0.5 mm <sup>2</sup> ... 2.5 mm <sup>2</sup>
2 conductors with the same cross section, flexible, with TWIN ferrule with plastic sleeve	0.5 mm <sup>2</sup> ... 6 mm <sup>2</sup>
Stripping length	12 mm
Tightening torque	1.2 Nm ... 1.5 Nm

# KDS10 GEHAEUSE HALBSCH. GN - PCB terminal block

1732490

<https://www.phoenixcontact.com/us/products/1732490>

## Mounting

Mounting type	Wave soldering
---------------	----------------

## Material specifications

### Material data - contact

Note	WEEE/RoHS-compliant, free of whiskers according to IEC 60068-2-82/JEDEC JESD 201
Contact material	Cu alloy
Surface characteristics	Tin-plated
Metal surface terminal point (top layer)	Tin (5 µm - 7 µm Sn)
Metal surface terminal point (middle layer)	Nickel (2 µm - 3 µm Ni)
Metal surface soldering area (top layer)	Tin (5 µm - 7 µm Sn)
Metal surface soldering area (middle layer)	Nickel (2 µm - 3 µm Ni)

### Material data - housing

Color (Housing)	green (6021)
Insulating material	PA
Insulating material group	I
CTI according to IEC 60112	600
Flammability rating according to UL 94	V0
Glow wire flammability index GWFI according to EN 60695-2-12	850
Glow wire ignition temperature GWIT according to EN 60695-2-13	775
Temperature for the ball pressure test according to EN 60695-10-2	125 °C

## Dimensions

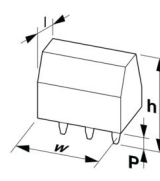
Dimensional drawing	
Pitch	10 mm
Pin dimensions	1 x 0.9 mm

## Mechanical tests

### Test for conductor damage and slackening

Specification	IEC 60998-2-1:1990-04
Result	Test passed

### Pull-out test

Specification	IEC 60998-2-1:1990-04
Conductor cross-section/conductor type/tractive force setpoint/actual value	0.5 mm <sup>2</sup> / solid / > 30 N
	0.5 mm <sup>2</sup> / flexible / > 30 N

# KDS10 GEHAEUSE HALBSCH. GN - PCB terminal block



1732490

<https://www.phoenixcontact.com/us/products/1732490>

	16 mm <sup>2</sup> / solid / > 100 N
	10 mm <sup>2</sup> / flexible / > 90 N

## Torque test

Specification	IEC 60998-2-1:1990-04
---------------	-----------------------

## Electrical tests

### Temperature-rise test

Specification	IEC 60998-2-1:1990-04
Requirement temperature-rise test	Increase in temperature ≤ 45 K

### Insulation resistance

Specification	IEC 60998-2-1:1990-04
Insulation resistance, neighboring positions	10 <sup>9</sup> Ω

### Air clearances and creepage distances |

Specification	IEC 60664-1:2007-04
Insulating material group	I
Comparative tracking index (IEC 60112)	CTI 600
Rated insulation voltage (III/3)	250 V
Rated surge voltage (III/3)	4 kV
minimum clearance value - non-homogenous field (III/3)	3 mm
minimum creepage distance (III/3)	3.2 mm
Rated insulation voltage (III/2)	320 V
Rated surge voltage (III/2)	4 kV
minimum clearance value - non-homogenous field (III/2)	3 mm
minimum creepage distance (III/2)	3 mm
Rated insulation voltage (II/2)	630 V
Rated surge voltage (II/2)	4 kV
minimum clearance value - non-homogenous field (II/2)	3 mm
minimum creepage distance (II/2)	3.2 mm

## Environmental and real-life conditions

### Vibration test

Specification	IEC 60068-2-6:1995-03
Frequency	10 - 150 - 10 Hz
Sweep speed	1 octave/min
Amplitude	0.35 mm (10 Hz ... 60.1 Hz)
Acceleration	5g (60.1 Hz ... 150 Hz)
Test duration per axis	2.5 h
Test directions	X-, Y- and Z-axis

### Glow-wire test

Specification	IEC 60998-2-1:1990-04
Temperature	850 °C

# KDS10 GEHAEUSE HALBSCH. GN - PCB terminal block



1732490

<https://www.phoenixcontact.com/us/products/1732490>

Time of exposure	5 s
Ambient conditions	
Ambient temperature (storage/transport)	-40 °C ... 70 °C
Relative humidity (storage/transport)	30 % ... 70 %
Ambient temperature (assembly)	-5 °C ... 100 °C
Ambient temperature (operation)	-40 °C ... 100 °C (Depending on the current carrying capacity/derating curve)

# KDS10 GEHAEUSE HALBSCH. GN - PCB terminal block



1732490

<https://www.phoenixcontact.com/us/products/1732490>

## Drawings

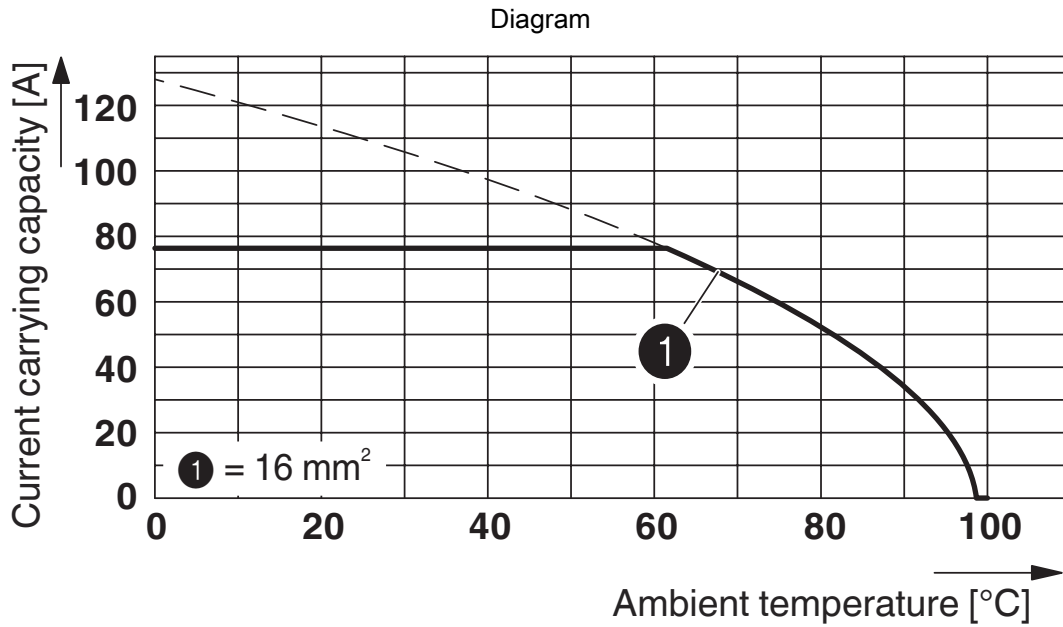

Type: KDS 10

Test following DIN EN 60512-5-2:2003-01

Reduction factor = 1

No. of positions: 5

# KDS10 GEHAEUSE HALBSCH. GN - PCB terminal block



1732490

<https://www.phoenixcontact.com/us/products/1732490>

## Classifications

### ECLASS

ECLASS-13.0	27460101
ECLASS-15.0	27460101

### ETIM

ETIM 10.0	EC002643
-----------	----------

### UNSPSC

UNSPSC 21.0	39121400
-------------	----------

# KDS10 GEHAEUSE HALBSCH. GN - PCB terminal block



1732490

<https://www.phoenixcontact.com/us/products/1732490>

## Environmental product compliance

### EU RoHS

Fulfills EU RoHS substance requirements	Yes, No exemptions
---	--------------------

### China RoHS

Environment friendly use period (EFUP)	EFUP-E
	No hazardous substances above the limits

### EU REACH SVHC

REACH candidate substance (CAS No.)	No substance above 0.1 wt%
-------------------------------------	----------------------------

### EF3.1 Climate Change

CO2e kg	0.017 kg CO2e
---------	---------------

Phoenix Contact 2026 © - all rights reserved  
<https://www.phoenixcontact.com>

Phoenix Contact USA  
586 Fulling Mill Road  
Middletown, PA 17057, United States  
(+717) 944-1300  
[info@phoenixcon.com](mailto:info@phoenixcon.com)