

LPCH 6/ 3+6-ST-7,62 - PCB hybrid connector

1716954

<https://www.phoenixcontact.com/us/products/1716954>

Please be informed that the data shown in this PDF document is generated from our online catalog. Please find the complete data in the user documentation. Our general terms of use for downloads are valid.

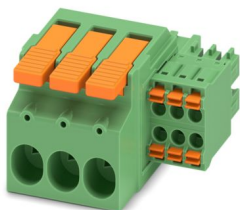

PCB hybrid connector, nominal cross section: 6 mm², color: green, nominal current: 41 A, 8 A, rated voltage (III/2): 1000 V, contact surface: Sn, contact connection type: Socket, number of potentials: 9, number of rows: 1, number of positions: 9, number of connections: 9, product range: LPCH 6/..+6-ST, pitch: 7.62 mm, connection method: Lever Push-in connection, conductor/PCB connection direction: 0 °, plug-in system: COMBICON PC 6 hybrid, locking: without, mounting method: without, type of packaging: packed in cardboard

Your advantages

- Tool-free lever principle enables time-saving connection and release of conductors with/without ferrules
- Clear lever positions provide reliable feedback on opened or closed clamping spaces
- Defined contact force ensures that contact remains stable over the long term
- Time-saving push-in connection when lever is closed

Commercial data

Item number	1716954
Packing unit	25 pc
Minimum order quantity	25 pc
Sales key	AA04
Product key	AADBAF
GTIN	4055626522548
Weight per piece (including packing)	27.5 g
Weight per piece (excluding packing)	25.624 g
Customs tariff number	85366990
Country of origin	SK

LPCH 6/ 3+6-ST-7,62 - PCB hybrid connector



1716954

<https://www.phoenixcontact.com/us/products/1716954>

Technical data

Product properties

Product type	PCB hybrid connector
Product family	LPCH 6/..+6-ST
Product line	COMBICON Connectors L
Number of positions	9
Pitch	7.62 mm
Number of connections	9
Number of rows	1
Number of potentials	9

Electrical properties

Properties

Nominal current I_N	41 A
Nominal voltage U_N	1000 V
Contact resistance	0.42 mΩ
Rated voltage (III/3)	800 V
Rated surge voltage (III/3)	8 kV
Rated voltage (III/2)	1000 V
Rated surge voltage (III/2)	8 kV
Rated voltage (II/2)	1000 V
Rated surge voltage (II/2)	6 kV

Connection data

Connection technology

Connector system	COMBICON PC 6 hybrid
Nominal cross section	6 mm ²
Contact connection type	Socket

Interlock

Locking type	without
Mounting type	without

Conductor connection Power

Connection method	Lever Push-in connection
Connection direction of the conductor to plug-in direction	0 °
Conductor cross-section rigid	0.75 mm ² ... 10 mm ²
Conductor cross-section flexible	0.75 mm ² ... 6 mm ²
Conductor cross-section AWG	18 ... 8
Conductor cross-section, flexible, with ferrule, without plastic sleeve	0.75 mm ² ... 6 mm ²
Conductor cross-section, flexible, with ferrule, with plastic sleeve	0.75 mm ² ... 6 mm ²
Cylindrical gauge a x b / diameter	4.3 mm x 4.0 mm / 4.0 mm

LPCH 6/ 3+6-ST-7,62 - PCB hybrid connector



1716954

<https://www.phoenixcontact.com/us/products/1716954>

Stripping length	18 mm
Conductor connection Signal	
Connection method	Push-in spring connection
Connection direction of the conductor to plug-in direction	0 °
Conductor cross-section rigid	0.2 mm ² ... 1.5 mm ²
Conductor cross-section flexible	0.2 mm ² ... 1.5 mm ²
Conductor cross-section AWG	24 ... 16
Conductor cross-section, flexible, with ferrule, without plastic sleeve	0.25 mm ² ... 1.5 mm ²
Conductor cross-section, flexible, with ferrule, with plastic sleeve	0.25 mm ² ... 1 mm ²
Cylindrical gauge a x b / diameter	2.4 mm x 1.5 mm / 1.5 mm
Stripping length	10 mm

Material specifications

Material data - contact

Note	WEEE/RoHS-compliant, free of whiskers according to IEC 60068-2-82/JEDEC JESD 201
Contact material	Cu alloy
Surface characteristics	Tin-plated
Metal surface terminal point (top layer)	Tin (4 µm - 8 µm Sn)
Metal surface contact area (top layer)	Tin (4 µm - 8 µm Sn)

Material data - housing

Color (Housing Power)	green (6021)
Insulating material	PA GF
Insulating material group	I
CTI according to IEC 60112	600
Flammability rating according to UL 94	V0

Material data – actuating element

Color (Actuating element)	orange (2003)
Insulating material	PA GF
Insulating material group	I
CTI according to IEC 60112	600
Flammability rating according to UL 94	V0

Notes

Notes on operation	In accordance with IEC 61984, COMBICON connectors have no switching power (COC). During designated use, they must not be plugged in or disconnected when carrying voltage or under load.
--------------------	--

Dimensions

LPCH 6/ 3+6-ST-7,62 - PCB hybrid connector



1716954

<https://www.phoenixcontact.com/us/products/1716954>

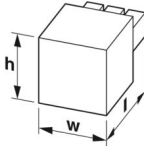
Dimensional drawing	
Pitch	7.62 mm
	3.81 mm
Width [w]	36.49 mm
Height [h]	24.3 mm
Length [l]	48 mm

Mechanical tests

Conductor connection

Specification	IEC 60999-1:1999-11
Result	Test passed

Test for conductor damage and slackening

Specification	IEC 60999-1:1999-11
Result	Test passed

Test for conductor damage and slackening

Specification	IEC 60999-1:1999-11
Result	Test passed

Repeated connection and disconnection

Specification	IEC 60999-1:1999-11
Result	Test passed

Pull-out test

Specification	IEC 60999-1:1999-11
Conductor cross-section/conductor type/tractive force setpoint/actual value	0.75 mm ² / solid / > 30 N
	0.75 mm ² / flexible / > 30 N
	10 mm ² / solid / > 90 N
	6 mm ² / flexible / > 80 N

Pull-out test

Specification	IEC 60999-1:1999-11
Conductor cross-section/conductor type/tractive force setpoint/actual value	0.2 mm ² / solid / > 10 N
	0.2 mm ² / flexible / > 10 N
	1.5 mm ² / solid / > 40 N
	1.5 mm ² / flexible / > 40 N

Insertion and withdrawal forces

Result	Test passed
No. of cycles	25
Insertion strength per pos. approx.	7 N

LPCH 6/ 3+6-ST-7,62 - PCB hybrid connector



1716954

<https://www.phoenixcontact.com/us/products/1716954>

Withdraw strength per pos. approx.	4 N
Contact holder in insert	
Specification	IEC 60512-15-1:2008-05
Contact holder in insert Requirements >20 N	Test passed
Resistance of inscriptions	
Specification	IEC 60068-2-70:1995-12
Result	Test passed
Polarization and coding	
Specification	IEC 60512-13-5:2006-02
Result	Test passed
Visual inspection	
Specification	IEC 60512-1-1:2002-02
Result	Test passed
Dimension check	
Specification	IEC 60512-1-2:2002-02
Result	Test passed

Electrical tests

Thermal test | Test group C

Specification	IEC 60512-5-1:2002-02
Tested number of positions	4

Insulation resistance

Specification	IEC 60512-3-1:2002-02
Insulation resistance, neighboring positions	> 5 MΩ

Temperature cycles

Specification	IEC 60999-1:1999-11
Result	Test passed

Air clearances and creepage distances | Power

Specification	IEC 60664-1:2007-04
Insulating material group	I
Comparative tracking index (IEC 60112)	CTI 600
Rated insulation voltage (III/3)	800 V
Rated surge voltage (III/3)	8 kV
minimum clearance value - non-homogenous field (III/3)	8 mm
minimum creepage distance (III/3)	10 mm
Rated insulation voltage (III/2)	1000 V
Rated surge voltage (III/2)	8 kV
minimum clearance value - non-homogenous field (III/2)	8 mm

LPCH 6/ 3+6-ST-7,62 - PCB hybrid connector



1716954

<https://www.phoenixcontact.com/us/products/1716954>

minimum creepage distance (III/2)	8 mm
Rated insulation voltage (II/2)	1000 V
Rated surge voltage (II/2)	6 kV
minimum clearance value - non-homogenous field (II/2)	5.5 mm
minimum creepage distance (II/2)	5.5 mm

Air clearances and creepage distances | Signal

Specification	IEC 60664-1:2007-04
Insulating material group	I
Comparative tracking index (IEC 60112)	CTI 600
Rated insulation voltage (III/3)	160 V
Rated surge voltage (III/3)	2.5 kV
minimum clearance value - non-homogenous field (III/3)	1.5 mm
minimum creepage distance (III/3)	2 mm
Rated insulation voltage (III/2)	160 V
Rated surge voltage (III/2)	2.5 kV
minimum clearance value - non-homogenous field (III/2)	1.5 mm
minimum creepage distance (III/2)	1.5 mm
Rated insulation voltage (II/2)	320 V
Rated surge voltage (II/2)	2.5 kV
minimum clearance value - non-homogenous field (II/2)	1.5 mm
minimum creepage distance (II/2)	1.6 mm

Environmental and real-life conditions

Durability test

Specification	IEC 60512-9-1:2010-03
Impulse withstand voltage at sea level	7.3 kV
Contact resistance R_1	0.42 m Ω
Contact resistance R_2	0.46 m Ω
Insertion/withdrawal cycles	25
Insulation resistance, neighboring positions	> 5 M Ω

Climatic test

Specification	ISO 6988:1985-02
Corrosive stress	0.2 dm ³ SO ₂ on 300 dm ³ /40 °C/1 cycle
Thermal stress	100 °C/168 h
Power-frequency withstand voltage	3.31 kV

Vibration test

Specification	IEC 60068-2-6:2007-12
Frequency	10 - 150 - 10 Hz
Sweep speed	1 octave/min
Amplitude	0.35 mm (10 Hz ... 60.1 Hz)
Acceleration	5g (60.1 Hz ... 150 Hz)
Test duration per axis	2.5 h

LPCH 6/ 3+6-ST-7,62 - PCB hybrid connector



1716954

<https://www.phoenixcontact.com/us/products/1716954>

Test directions	X-, Y- and Z-axis
-----------------	-------------------

Ambient conditions

Ambient temperature (storage/transport)	-40 °C ... 70 °C
Relative humidity (storage/transport)	30 % ... 70 %
Ambient temperature (assembly)	-5 °C ... 100 °C
Ambient temperature (operation)	-40 °C ... 105 °C (dependent on the derating curve)

Ambient conditions

Ambient temperature (operation)	-40 °C ... 105 °C (dependent on the derating curve)
Ambient temperature (storage/transport)	-40 °C ... 70 °C
Relative humidity (storage/transport)	30 % ... 70 %
Ambient temperature (assembly)	-5 °C ... 100 °C

Packaging specifications

Type of packaging	packed in cardboard
-------------------	---------------------

Drawings

Diagram

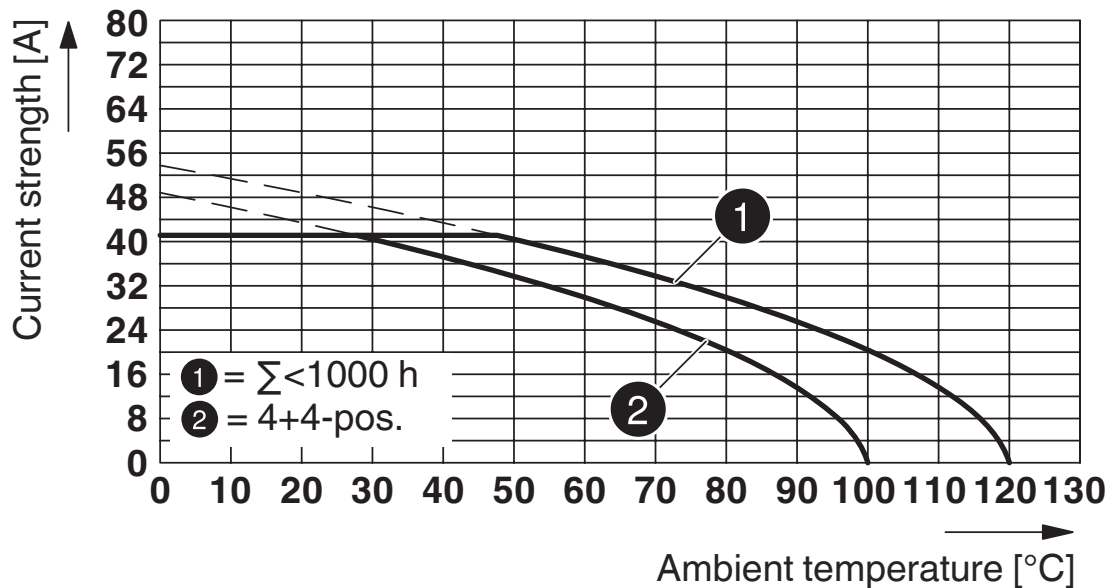

Type: LPCH 6/...+...-ST-7,62 with PCH 6/...+...-G-7,62

Diagram

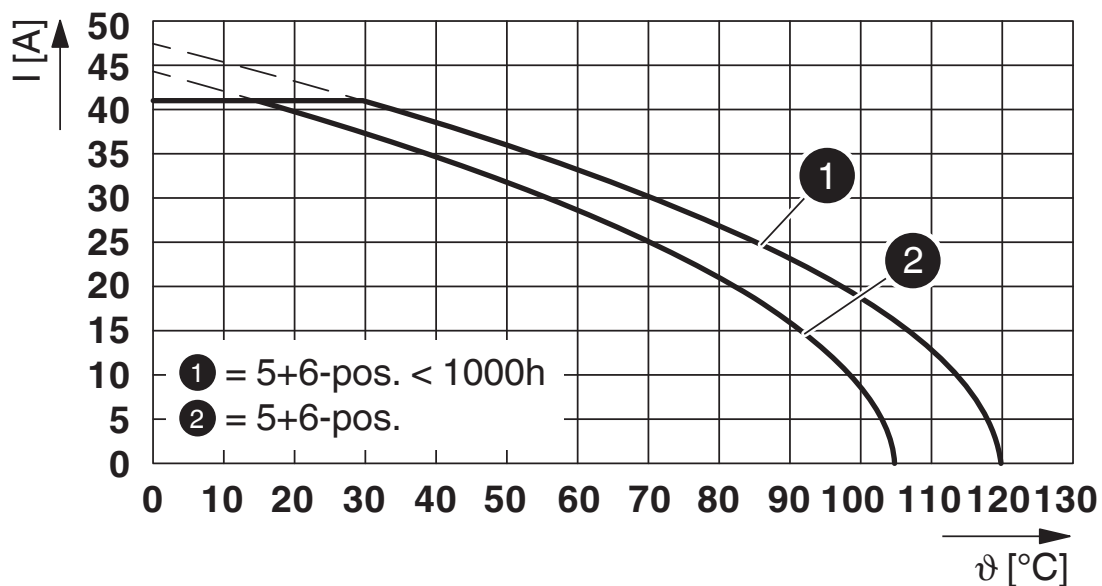

Type: LPCH 6/...+...-ST-7,62 with PCH 6/...+...-G-7,62 P...THR

LPCH 6/ 3+6-ST-7,62 - PCB hybrid connector



1716954

<https://www.phoenixcontact.com/us/products/1716954>

Diagram

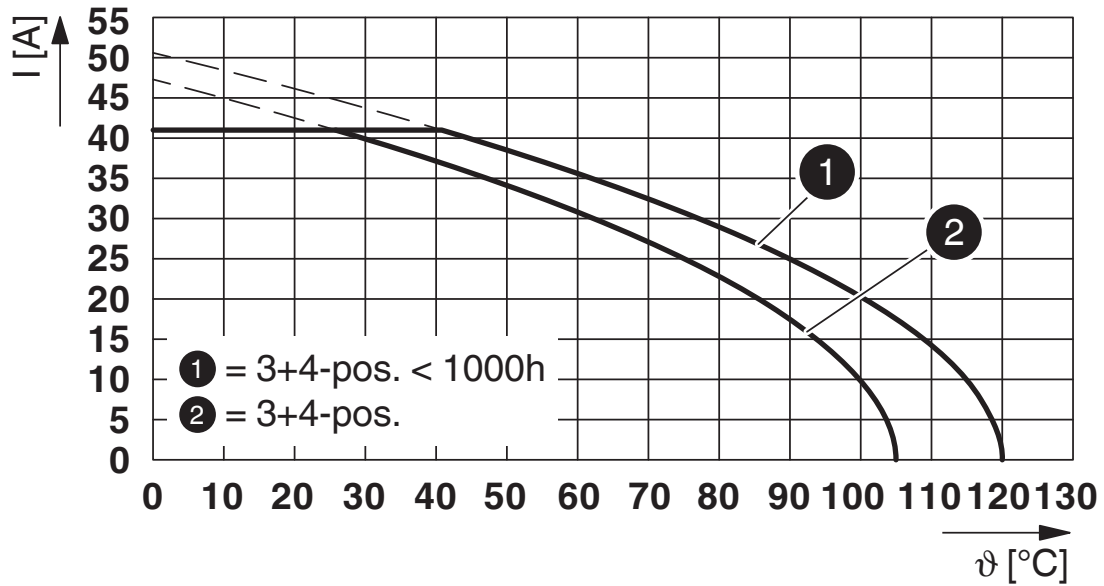

Type: LPCH 6/...+...-ST-7,62 with PCH 6/...+...-G-7,62 P...THR

LPCH 6/ 3+6-ST-7,62 - PCB hybrid connector



1716954

<https://www.phoenixcontact.com/us/products/1716954>

Approvals

To download certificates, visit the product detail page: <https://www.phoenixcontact.com/us/products/1716954>

 cULus Recognized Approval ID: E60425-20010727				
	Nominal voltage U_N	Nominal current I_N	Cross section AWG	Cross section mm^2
B				
Power	600 V	35 A	18 - 8	-
Signal	150 V	8 A	24 - 16	-
C				
Power	600 V	35 A	18 - 8	-
Signal	50 V	8 A	24 - 16	-

 VDE Zeichengenehmigung Approval ID: 40050635				
	Nominal voltage U_N	Nominal current I_N	Cross section AWG	Cross section mm^2
keine				
Power	630 V	41 A	-	0.75 - 6
Signal	160 V	8 A	-	0.2 - 1.5

 UL Recognized Approval ID: E60425-20010727				
	Nominal voltage U_N	Nominal current I_N	Cross section AWG	Cross section mm^2
F				
Power	600 V	35 A	18 - 8	-
Signal	160 V	8 A	24 - 16	-

LPCH 6/ 3+6-ST-7,62 - PCB hybrid connector



1716954

<https://www.phoenixcontact.com/us/products/1716954>

Classifications

ECLASS

ECLASS-13.0	27460302
ECLASS-15.0	27460302

ETIM

ETIM 10.0	EC002638
-----------	----------

UNSPSC

UNSPSC 21.0	39121400
-------------	----------

LPCH 6/ 3+6-ST-7,62 - PCB hybrid connector



1716954

<https://www.phoenixcontact.com/us/products/1716954>

Environmental product compliance

EU RoHS

Fulfills EU RoHS substance requirements	Yes, No exemptions
---	--------------------

China RoHS

Environment friendly use period (EFUP)	EFUP-E
	No hazardous substances above the limits

EU REACH SVHC

REACH candidate substance (CAS No.)	No substance above 0.1 wt%
-------------------------------------	----------------------------

Phoenix Contact 2026 © - all rights reserved
<https://www.phoenixcontact.com>

Phoenix Contact USA
586 Fulling Mill Road
Middletown, PA 17057, United States
(+717) 944-1300
info@phoenixcon.com