

GKDS-EX - PCB terminal block



1709203

<https://www.phoenixcontact.com/us/products/1709203>

Please be informed that the data shown in this PDF document is generated from our online catalog. Please find the complete data in the user documentation. Our general terms of use for downloads are valid.



Printed circuit board terminal, nominal current: 20 A, nominal cross section: 2.5 mm², number of potentials: 1, number of rows: 1, number of positions per row: 1, product range: GKDS-EX, pitch: 7.5 mm, connection method: Screw connection with tension sleeve, screw head form: L Slotted, mounting: Wave soldering, conductor/PCB connection direction: 0 °, color: black, Pin layout: Linear pinning, Solder pin [P]: 5 mm, number of solder pins per potential: 2, type of packaging: packed in cardboard. The article can be aligned to create different nos. of positions! Every group of terminal blocks is to be provided with a GRZ 2,5V-EX (1706112) flange plate on both sides. If there are more than 10 terminal blocks, at least one additional flange plate must be mounted for each further group of ten. When the pitch spacer GRZ 2,5-EX (1724628) is used, the max. working voltage is increased to 420 V.

Your advantages

- Well-known connection principle allows worldwide use
- Low temperature rise, thanks to maximum contact force
- Satisfies the more stringent safety requirements of "Ex e" protection according to IEC 60079-7 for potentially explosive areas
- Quick and convenient testing using integrated test option
- Two solder pins reduce the mechanical strain on the soldering spots
- The latching on the side enables various numbers of positions to be combined

Commercial data

Item number	1709203
Packing unit	50 pc
Minimum order quantity	50 pc
Sales key	AA13
Product key	AAMFGA
GTIN	4017918023638
Weight per piece (including packing)	4.317 g
Weight per piece (excluding packing)	3.991 g
Customs tariff number	85369010
Country of origin	DE

Technical data

Product properties

Product type	Printed circuit board terminal
Product family	GKDS-EX
Product line	COMBICON Terminals M
Type	PC terminal block can be aligned
Number of positions	1
Pitch	7.5 mm
Number of connections	1
Number of rows	1
Number of potentials	1
Pin layout	Linear pinning
Solder pins per potential	2

Electrical properties

Properties

Nominal current I_N	20 A
Nominal voltage U_N	275 V
Rated current / conductor cross-section	20 A/2.5 mm ²

Connection data

Connection technology

Type	PC terminal block can be aligned
Nominal cross section	2.5 mm ²

Conductor connection

Connection method	Screw connection with tension sleeve
Conductor cross-section rigid	0.2 mm ² ... 4 mm ²
Conductor cross-section flexible	0.2 mm ² ... 2.5 mm ²
Conductor cross-section AWG	24 ... 12
Conductor cross-section, flexible, with ferrule, without plastic sleeve	0.25 mm ² ... 2.5 mm ²
Conductor cross-section, flexible, with ferrule, with plastic sleeve	0.25 mm ² ... 2.5 mm ²
2 conductors with same cross section, rigid	0.2 mm ² ... 1.5 mm ²
2 conductors with same cross section, flexible	0.2 mm ² ... 1 mm ²
2 conductors with same cross section, flexible, with ferrule without plastic sleeve	0.25 mm ² ... 0.5 mm ²
2 conductors with the same cross section, flexible, with TWIN ferrule with plastic sleeve	0.5 mm ² ... 1 mm ²
Stripping length	9 mm
Drive form screw head	Slotted (L)
Tightening torque	0.5 Nm ... 0.6 Nm

GKDS-EX - PCB terminal block

1709203

<https://www.phoenixcontact.com/us/products/1709203>

Mounting

Mounting type	Wave soldering
Pin layout	Linear pinning

Material specifications

Material data - contact

Note	WEEE/RoHS-compliant, free of whiskers according to IEC 60068-2-82/JEDEC JESD 201
Contact material	Cu alloy
Surface characteristics	Tin-plated
Metal surface terminal point (top layer)	Tin (5 μm - 7 μm Sn)
Metal surface terminal point (middle layer)	Nickel (2 μm - 3 μm Ni)
Metal surface soldering area (top layer)	Tin (5 μm - 7 μm Sn)
Metal surface soldering area (middle layer)	Nickel (2 μm - 3 μm Ni)

Material data - housing

Color (Housing)	black (9005)
Insulating material	PA
Insulating material group	I
CTI according to IEC 60112	600
Flammability rating according to UL 94	V0
Glow wire flammability index GWFI according to EN 60695-2-12	850
Glow wire ignition temperature GWIT according to EN 60695-2-13	775
Temperature for the ball pressure test according to EN 60695-10-2	125 °C

Dimensions

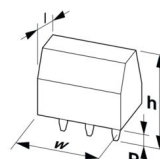
Dimensional drawing	
Pitch	7.5 mm
Width [w]	7.5 mm
Height [h]	19.5 mm
Length [l]	19 mm
Installed height	20 mm
Solder pin length [P]	5 mm
Pin dimensions	1.1 x 0.8 mm

PCB design

Hole diameter	1.4 mm
---------------	--------

GKDS-EX - PCB terminal block



1709203

<https://www.phoenixcontact.com/us/products/1709203>

Electrical tests

Air clearances and creepage distances |

Insulating material group	I
---------------------------	---

Environmental and real-life conditions

Ambient conditions

Ambient temperature (storage/transport)	-40 °C ... 70 °C
Relative humidity (storage/transport)	30 % ... 70 %
Ambient temperature (assembly)	-5 °C ... 100 °C
Ambient temperature (operation)	-25 °C ... 80 °C

Packaging specifications

Type of packaging	packed in cardboard
-------------------	---------------------

GKDS-EX - PCB terminal block

1709203

<https://www.phoenixcontact.com/us/products/1709203>

Drawings

Dimensional drawing

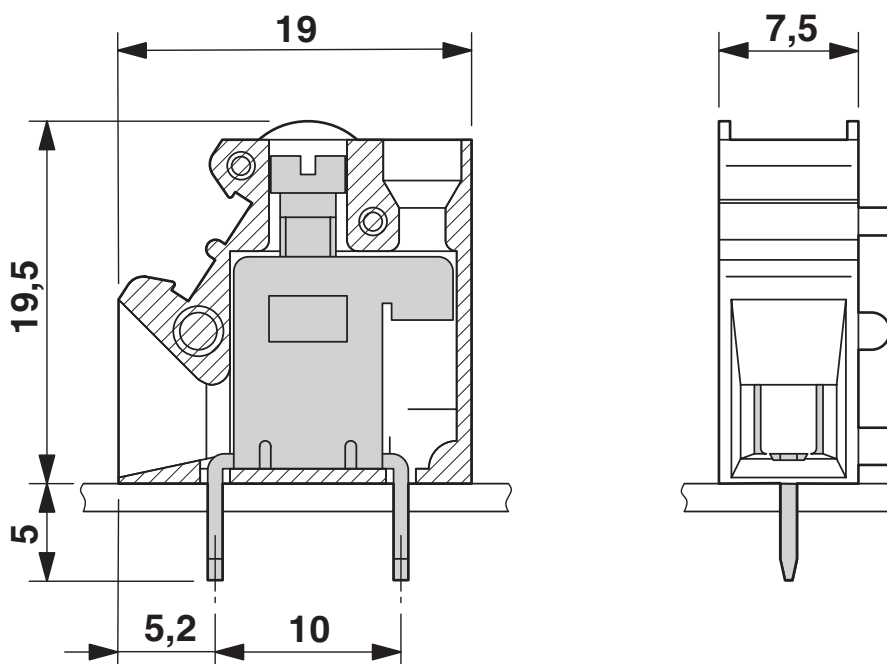

Dimensional drawing

Flange plate
GRZ 2.5 V-EX

Pitch spacer
GRZ 2,5-EX

Terminal block
GKDS-EX

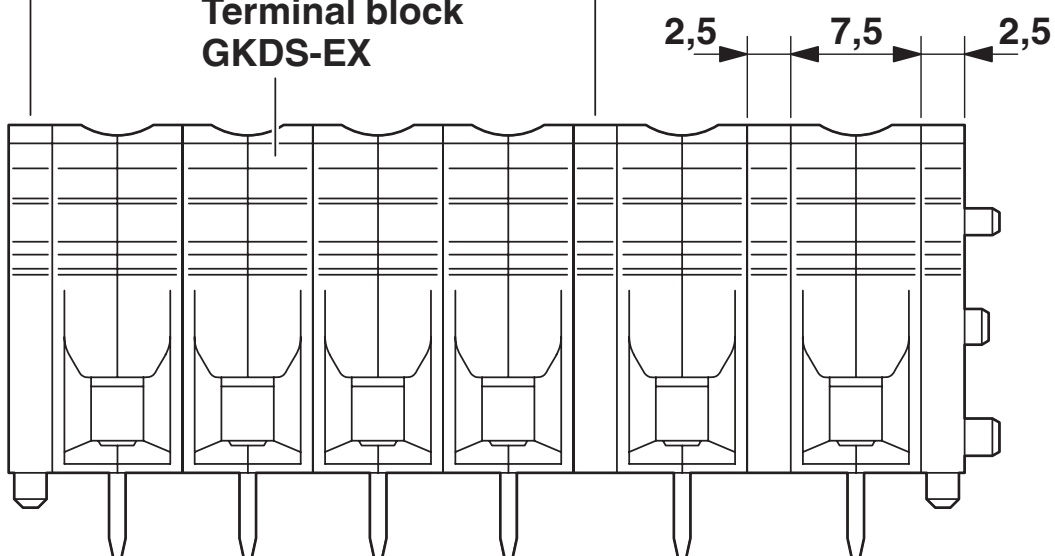

Installation instructions

GKDS-EX - PCB terminal block

1709203

<https://www.phoenixcontact.com/us/products/1709203>

Schematic diagram

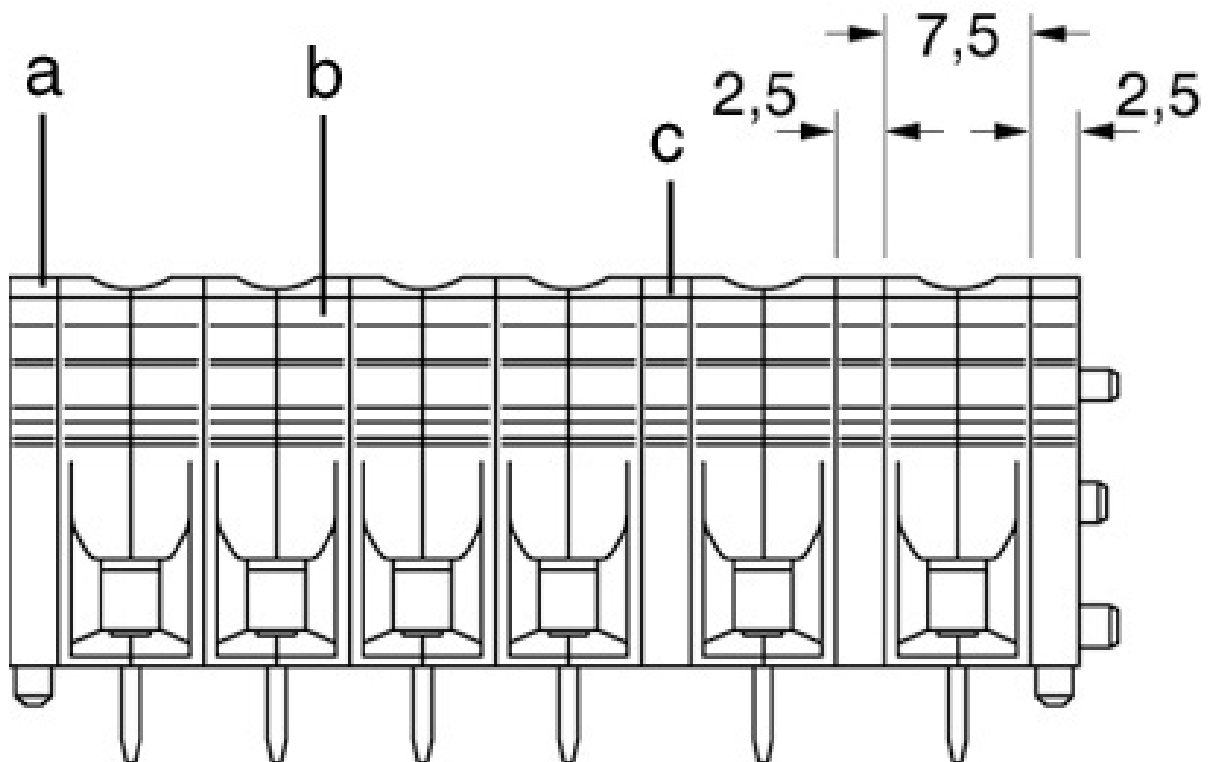

- a = Flange plate, GRZ 2,5 V-EX
- b = Terminal block GKDS-EX
- c = Pitch spacer GRZ 2,5-EX

GKDS-EX - PCB terminal block

1709203

<https://www.phoenixcontact.com/us/products/1709203>



Drilling plan/solder pad geometry

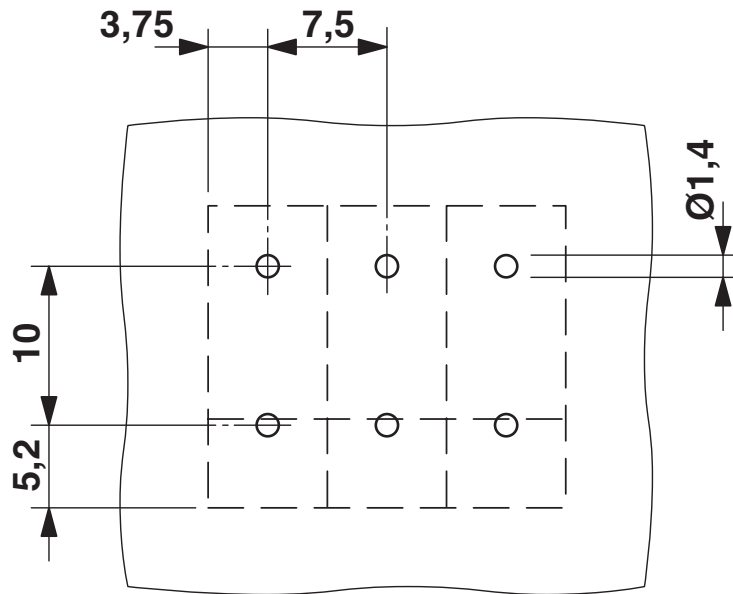

GKDS-EX - PCB terminal block





1709203

<https://www.phoenixcontact.com/us/products/1709203>

Approvals

To download certificates, visit the product detail page: <https://www.phoenixcontact.com/us/products/1709203>

 ATEX Approval ID: SEV 15 ATEX 0178 U				
	Nominal voltage U_N	Nominal current I_N	Cross section AWG	Cross section mm^2
keine				
	275 V	20 A	-	0.2 - 2.5
Only rigid conductors	275 V	26 A	-	- 4
with pitch spacer	420 V	20 A	-	0.2 - 2.5

 cUL Recognized Approval ID: FILE E 192998				
	Nominal voltage U_N	Nominal current I_N	Cross section AWG	Cross section mm^2
B				
	160 V	15 A	30 - 14	30 - 14
with pitch spacer	250 V	-	30 - 14	30 - 14
C				
	50 V	15 A	30 - 14	30 - 14
D				
	160 V	10 A	30 - 14	30 - 14
with pitch spacer	250 V	-	30 - 14	30 - 14

 IECEx Approval ID: IECEx SEV 15.0026U				
	Nominal voltage U_N	Nominal current I_N	Cross section AWG	Cross section mm^2
keine				
	275 V	20 A	-	0.2 - 2.5
Only rigid conductors	275 V	26 A	-	- 4
with pitch spacer	420 V	20 A	-	0.2 - 2.5

 UL Recognized Approval ID: FILE E 192998				
	Nominal voltage U_N	Nominal current I_N	Cross section AWG	Cross section mm^2
B				
	160 V	15 A	30 - 14	-
with pitch spacer	250 V	-	30 - 14	-
C				
	50 V	15 A	30 - 14	-
D				

GKDS-EX - PCB terminal block



1709203

<https://www.phoenixcontact.com/us/products/1709203>

	160 V	10 A	30 - 14	-
with pitch spacer	250 V	-	30 - 14	-

GKDS-EX - PCB terminal block



1709203

<https://www.phoenixcontact.com/us/products/1709203>

Classifications

ECLASS

ECLASS-13.0	27460101
ECLASS-15.0	27460101

ETIM

ETIM 10.0	EC002643
-----------	----------

UNSPSC

UNSPSC 21.0	39121400
-------------	----------

GKDS-EX - PCB terminal block



1709203

<https://www.phoenixcontact.com/us/products/1709203>

Environmental product compliance

EU RoHS

Fulfills EU RoHS substance requirements	Yes, No exemptions
---	--------------------

China RoHS

Environment friendly use period (EFUP)	EFUP-E
	No hazardous substances above the limits

EU REACH SVHC

REACH candidate substance (CAS No.)	No substance above 0.1 wt%
-------------------------------------	----------------------------

EF3.1 Climate Change

CO2e kg	0.048 kg CO2e
---------	---------------

Phoenix Contact 2026 © - all rights reserved
<https://www.phoenixcontact.com>

Phoenix Contact USA
586 Fulling Mill Road
Middletown, PA 17057, United States
(+717) 944-1300
info@phoenixcon.com