

# FK-MC 0,5/ 5-ST-2,5 AU BD:1-5 - PCB connector



1707336

<https://www.phoenixcontact.com/us/products/1707336>

Please be informed that the data shown in this PDF document is generated from our online catalog. Please find the complete data in the user documentation. Our general terms of use for downloads are valid.

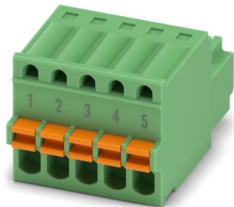

PCB connector, nominal cross section: 0.5 mm<sup>2</sup>, color: green, nominal current: 4 A, rated voltage (III/2): 160 V, contact surface: Au, contact connection type: Socket, number of potentials: 5, number of rows: 1, number of positions: 5, number of connections: 5, product range: FK-MC 0,5/.-ST, pitch: 2.5 mm, connection method: Push-in spring connection, conductor/PCB connection direction: 0 °, plug-in system: COMBICON FK-MC 0,5, locking: without, mounting method: without, type of packaging: packed in cardboard

## Your advantages

- Gold-plated contacts ensure transfer quality remains stable over the long term
- Time saving push-in connection, tools not required
- Defined contact force ensures that contact remains stable over the long term
- Intuitive operation due to color-coded actuating push button
- Operation and conductor connection from one direction enable integration into front of device
- Quick and convenient testing using integrated test option

## Commercial data

Item number	1707336
Packing unit	50 pc
Minimum order quantity	50 pc
Product key	AAAFCA
GTIN	4046356917681
Weight per piece (including packing)	3.27 g
Weight per piece (excluding packing)	2.83 g
Country of origin	DE

1707336

<https://www.phoenixcontact.com/us/products/1707336>

## Technical data

### Product properties

Product type	PCB connector
Product family	FK-MC 0,5/...-ST
Product line	COMBICON Connectors XS
Number of positions	5
Pitch	2.5 mm
Number of connections	5
Number of rows	1
Number of potentials	5
Mounting type	without

### Electrical properties

#### Properties

Nominal current $I_N$	4 A
Nominal voltage $U_N$	160 V
Rated voltage (III/3)	100 V
Rated surge voltage (III/3)	1.5 kV
Rated voltage (III/2)	160 V
Rated surge voltage (III/2)	2.5 kV
Rated voltage (II/2)	320 V
Rated surge voltage (II/2)	2.5 kV

### Connection data

#### Connection technology

Connector system	COMBICON FK-MC 0,5
Nominal cross section	0.5 mm <sup>2</sup>
Contact connection type	Socket

#### Interlock

Locking type	without
Mounting type	without

#### Conductor connection

Connection method	Push-in spring connection
Conductor/PCB connection direction	0 °
Conductor cross-section rigid	0.14 mm <sup>2</sup> ... 0.5 mm <sup>2</sup>
Conductor cross-section flexible	0.14 mm <sup>2</sup> ... 0.5 mm <sup>2</sup>
Conductor cross-section AWG	26 ... 20
Conductor cross-section, flexible, with ferrule, without plastic sleeve	0.25 mm <sup>2</sup> ... 0.5 mm <sup>2</sup>
Stripping length	8 mm

# FK-MC 0,5/ 5-ST-2,5 AU BD:1-5 - PCB connector



1707336

<https://www.phoenixcontact.com/us/products/1707336>

## Specifications for ferrules without insulating collar

recommended crimping tool	1212034 CRIMPFOX 6
ferrules without insulating collar, according to DIN 46228-1	Cross section: 0.25 mm <sup>2</sup> ; Length: 7 mm ... 8 mm
	Cross section: 0.34 mm <sup>2</sup> ; Length: 7 mm ... 8 mm
	Cross section: 0.5 mm <sup>2</sup> ; Length: 8 mm

## Material specifications

### Material data - contact

Note	WEEE/RoHS-compliant, free of whiskers according to IEC 60068-2-82/JEDEC JESD 201
Contact material	Cu alloy
Surface characteristics	Completely gold-plated
Metal surface terminal point (top layer)	Gold (0.8 µm - 1.4 µm Au)
Metal surface terminal point (middle layer)	Nickel (2 µm - 3 µm Ni)
Metal surface contact area (top layer)	Gold (0.8 µm - 1.4 µm Au)
Metal surface contact area (middle layer)	Nickel (2 µm - 3 µm Ni)

### Material data - housing

Color (Housing)	green (6021)
Insulating material	PA
Insulating material group	I
CTI according to IEC 60112	600
Flammability rating according to UL 94	V0
Glow wire flammability index GWFI according to EN 60695-2-12	850
Glow wire ignition temperature GWIT according to EN 60695-2-13	775
Temperature for the ball pressure test according to EN 60695-10-2	125 °C

### Material data – actuating element

Color (Actuating element)	orange (2003)
Insulating material	PBT
Insulating material group	I
CTI according to IEC 60112	600
Flammability rating according to UL 94	V0

## Dimensions

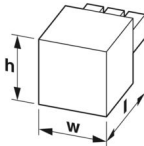
Dimensional drawing	
Pitch	2.5 mm
Width [w]	13.1 mm

1707336

<https://www.phoenixcontact.com/us/products/1707336>

Height [h]	11.75 mm
Length [l]	19.05 mm

## Environmental and real-life conditions

### Ambient conditions

Ambient temperature (storage/transport)	-40 °C ... 70 °C
Relative humidity (storage/transport)	30 % ... 70 %
Ambient temperature (assembly)	-5 °C ... 100 °C
Ambient temperature (operation)	-40 °C ... 100 °C (dependent on the derating curve)

## Electrical tests

### Air clearances and creepage distances |

Specification	IEC 60664-1:1992-10 + A1:2000-02 + A2:2002-05
Insulating material group	I
Rated insulation voltage (III/3)	100 V
Rated surge voltage (III/3)	1.5 kV
minimum clearance value - non-homogenous field (III/3)	0.8 mm
minimum creepage distance (III/3)	1.8 mm
Rated insulation voltage (III/2)	160 V
Rated surge voltage (III/2)	2.5 kV
minimum clearance value - non-homogenous field (III/2)	1.5 mm
minimum creepage distance (III/2)	1.5 mm
Rated insulation voltage (II/2)	320 V
Rated surge voltage (II/2)	2.5 kV
minimum clearance value - non-homogenous field (II/2)	1.5 mm
minimum creepage distance (II/2)	1.6 mm

## Packaging specifications

Type of packaging	packed in cardboard
-------------------	---------------------

# FK-MC 0,5/ 5-ST-2,5 AU BD:1-5 - PCB connector





1707336

<https://www.phoenixcontact.com/us/products/1707336>

## Approvals

To download certificates, visit the product detail page: <https://www.phoenixcontact.com/us/products/1707336>

 <b>cULus Recognized</b> Approval ID: E60425-19990913				
	Nominal voltage $U_N$	Nominal current $I_N$	Cross section AWG	Cross section $\text{mm}^2$
B	125 V	4 A	28 - 20	-

 <b>VDE report with production monitoring</b> Approval ID: 40013394				
	Nominal voltage $U_N$	Nominal current $I_N$	Cross section AWG	Cross section $\text{mm}^2$
keine	100 V	4 A	-	0.2 - 0.5

# FK-MC 0,5/ 5-ST-2,5 AU BD:1-5 - PCB connector



1707336

<https://www.phoenixcontact.com/us/products/1707336>

## Classifications

### ECLASS

ECLASS-13.0	27460202
ECLASS-15.0	27460202

### ETIM

ETIM 10.0	EC002638
-----------	----------

### UNSPSC

UNSPSC 21.0	39121400
-------------	----------

# FK-MC 0,5/ 5-ST-2,5 AU BD:1-5 - PCB connector



1707336

<https://www.phoenixcontact.com/us/products/1707336>

## Environmental product compliance

### EU RoHS

Fulfills EU RoHS substance requirements	Yes, No exemptions
---	--------------------

### China RoHS

Environment friendly use period (EFUP)	EFUP-E
	No hazardous substances above the limits

### EU REACH SVHC

REACH candidate substance (CAS No.)	No substance above 0.1 wt%
-------------------------------------	----------------------------

Phoenix Contact 2026 © - all rights reserved  
<https://www.phoenixcontact.com>

Phoenix Contact USA  
586 Fulling Mill Road  
Middletown, PA 17057, United States  
(+717) 944-1300  
[info@phoenixcon.com](mailto:info@phoenixcon.com)