

# PV-FT-CCM-6-R1000 - Crimp contact



1704928

<https://www.phoenixcontact.com/us/products/1704928>

Please be informed that the data shown in this PDF document is generated from our online catalog. Please find the complete data in the user documentation. Our general terms of use for downloads are valid.



Crimp contact, series: SUNCLIX, Pin, rolled, rated current: 40 A, connection cross section: 6 mm<sup>2</sup> ... 6 mm<sup>2</sup>, contact material: Cu

## Your advantages

- High-quality materials ensure a high degree of reliability and long-term stability
- Maximum system efficiency with proven, low-loss SUNCLIX contacts
- International approvals enable worldwide use

## Commercial data

Item number	1704928
Packing unit	1,000 pc
Minimum order quantity	1,000 pc
Sales key	AB02
Product key	ABLBFA
GTIN	4046356746212
Weight per piece (including packing)	2.416 g
Weight per piece (excluding packing)	1.681 g
Customs tariff number	85359000
Country of origin	DE

## Technical data

### Notes

#### Note on connection

Notes on operation	Crimping recommendation: Crimp the conductor with the crimp contact in accordance with IEC 60352
--------------------	--

#### Note on application

Note on application	When using the CRIMPFOX-P SR 6 manual crimping tool, item no. 1212755, please note the use of the standard locator (no marking).
---------------------	--

#### Safety note

Safety note	<ul style="list-style-type: none"> <li>• <b>WARNING:</b> Commission properly functioning products only. The products must be regularly inspected for damage. Decommission defective products immediately. Replace damaged products. Repairs are not possible.</li> </ul>
	<ul style="list-style-type: none"> <li>• <b>WARNING:</b> Only electrically qualified personnel may install and operate the product. They must observe the following safety notes. The qualified personnel must be familiar with the basics of electrical engineering. They must be able to recognize and prevent danger. The relevant symbol on the packaging indicates that only personnel familiar with electrical engineering are allowed to install and operate the product.</li> </ul>
	<p><b>WARNING:</b> The connectors may not be plugged in or disconnected under load. Ignoring the warning or improper use may damage persons and/or property.</p>
	<ul style="list-style-type: none"> <li>• The products are suitable for applications in plant, controller, and electrical device engineering.</li> </ul>
	<ul style="list-style-type: none"> <li>• Assembled products may not be manipulated or improperly opened.</li> </ul>
	<ul style="list-style-type: none"> <li>• Only use mating connectors that are specified in the technical data of the standards listed (e.g. the ones listed in the product accessories online at <a href="https://www.phoenixcontact.com/products">phoenixcontact.com/products</a>).</li> </ul>
	<ul style="list-style-type: none"> <li>• When using the product in direct connection with third-party manufacturers, the user is responsible.</li> </ul>
	<ul style="list-style-type: none"> <li>• For operating voltages &gt; 50 V AC, conductive connector housings must be grounded</li> </ul>
	<ul style="list-style-type: none"> <li>• Ensure that the protective or functional ground has been properly connected.</li> </ul>
	<ul style="list-style-type: none"> <li>• Observe the corresponding technical data. You will find information:                             <ul style="list-style-type: none"> <li>o On the product</li> <li>o On the packing label</li> <li>o In the supplied documentation</li> <li>o Online at <a href="https://www.phoenixcontact.com/products">phoenixcontact.com/products</a> under the product</li> </ul> </li> </ul>
<ul style="list-style-type: none"> <li>• The installation notes/Design In documents online on the download page at <a href="https://www.phoenixcontact.com/products">phoenixcontact.com/products</a> must be observed for this product.</li> </ul>	
<ul style="list-style-type: none"> <li>• Use a protective cap to protect connectors that are not in use. The suitable accessories are available online in the accessory section of the product at <a href="https://www.phoenixcontact.com/products">phoenixcontact.com/products</a></li> </ul>	

# PV-FT-CCM-6-R1000 - Crimp contact



1704928

<https://www.phoenixcontact.com/us/products/1704928>

- The connector warms up in normal operation. Depending on the ambient conditions, the surface of the connector can continue to warm up. In this case, the user is responsible for posting warnings (e.g. DIN EN ISO 13732-1:2008-12).
- Operate the connector only when it is fully plugged in and interlocked.
- Ensure that when laying the cable, the tensile load on the connectors does not exceed the upper limit specified in the standards.
- Observe the minimum bending radius of the cable. Lay the cable without twisting it.

## Product properties

Product type	Crimp contact
Series	SUNCLIX
Contact material type	rolled

## Connection data

### Connection technology

Contact connection type	Pin
Connection method	Crimp connection

### Conductor connection

Stripping length	8 mm +1 mm
Connection cross section	6 mm <sup>2</sup> ... 6 mm <sup>2</sup>

## Material specifications

Material Contact	Cu
Material Contact surface	Ag
Flammability rating according to UL 94	V0

## Dimensions

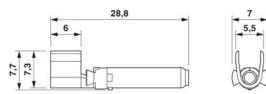
Dimensional drawing	
Width [w]	7 mm
Height [h]	7.7 mm
Length [l]	28.8 mm

## Electrical properties

Rated current (6,0 mm <sup>2</sup> )	40 A
Resistance (Durchgangswiderstand)	0.45 mΩ
Resistance (Übergangswiderstand)	≤ 0.45 mΩ (when plugged in)

## Mechanical properties

# PV-FT-CCM-6-R1000 - Crimp contact



1704928

<https://www.phoenixcontact.com/us/products/1704928>

## Mechanical data

Insertion/withdrawal cycles	100
Insertion force	≤ 20 N (uninstalled state)
Withdrawal force	≤ 20 N (uninstalled state)

## Environmental and real-life conditions

### Ambient conditions

Ambient temperature (operation)	-40 °C ... 85 °C (installed with PV-...-HSG)
Ambient temperature (assembly)	-25 °C ... 50 °C

# PV-FT-CCM-6-R1000 - Crimp contact



1704928

<https://www.phoenixcontact.com/us/products/1704928>

## Drawings

Dimensional drawing

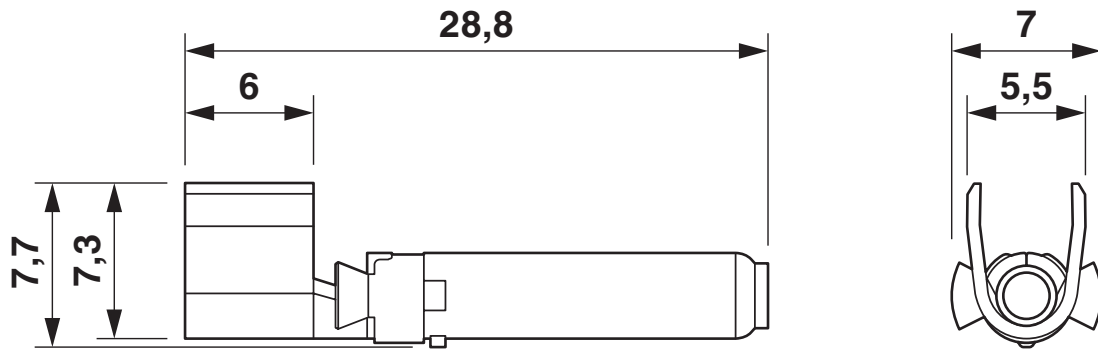

Dimensional drawing

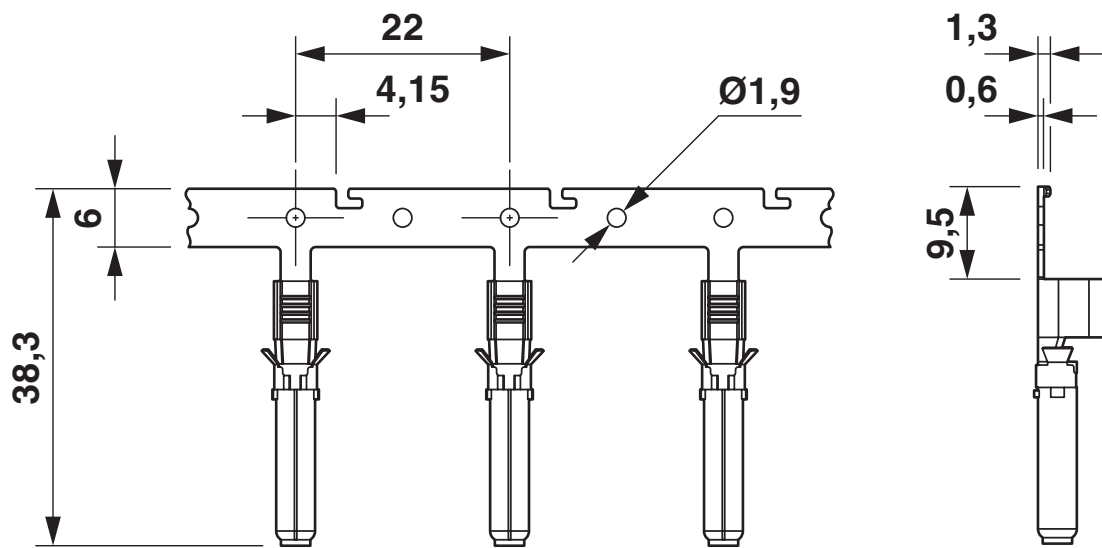

# PV-FT-CCM-6-R1000 - Crimp contact



1704928

<https://www.phoenixcontact.com/us/products/1704928>

## Classifications

### ECLASS

ECLASS-13.0	27440204
ECLASS-15.0	27440204

### ETIM

ETIM 10.0	EC000796
-----------	----------

### UNSPSC

UNSPSC 21.0	39121500
-------------	----------

# PV-FT-CCM-6-R1000 - Crimp contact



1704928

<https://www.phoenixcontact.com/us/products/1704928>

## Environmental product compliance

### EU RoHS

Fulfills EU RoHS substance requirements	Yes, No exemptions
---	--------------------

### China RoHS

Environment friendly use period (EFUP)	EFUP-E
	No hazardous substances above the limits

### EU REACH SVHC

REACH candidate substance (CAS No.)	No substance above 0.1 wt%
-------------------------------------	----------------------------

Phoenix Contact 2026 © - all rights reserved  
<https://www.phoenixcontact.com>

Phoenix Contact USA  
586 Fulling Mill Road  
Middletown, PA 17057, United States  
(+717) 944-1300  
[info@phoenixcon.com](mailto:info@phoenixcon.com)