

PV-FT-C2F-HSG - Photovoltaic connector



1704926

<https://www.phoenixcontact.com/us/products/1704926>

Please be informed that the data shown in this PDF document is generated from our online catalog. Please find the complete data in the user documentation. Our general terms of use for downloads are valid.



Photovoltaic connector, Range of articles: SUNCLIX, color: black, number of positions: 1, rated voltage: 1000 V DC, rated current: 40 A, Connection method: Crimp

Your advantages

- High yield, thanks to silver-plated contacts
- Patented UNLOCK system allows smaller center distances as well as convenient release
- Unique SUNCLIX pin connector pattern

Commercial data

Item number	1704926
Packing unit	50 pc
Minimum order quantity	50 pc
Sales key	AB02
Product key	ABLBAB
GTIN	4046356746236
Weight per piece (including packing)	3.84 g
Weight per piece (excluding packing)	3.294 g
Customs tariff number	85359000
Country of origin	DE

Technical data

Notes

Safety note

<p>Safety note</p>	<ul style="list-style-type: none"> • WARNING: Commission properly functioning products only. The products must be regularly inspected for damage. Decommission defective products immediately. Replace damaged products. Repairs are not possible. • WARNING: Only electrically qualified personnel may install and operate the product. They must observe the following safety notes. The qualified personnel must be familiar with the basics of electrical engineering. They must be able to recognize and prevent danger. The relevant symbol on the packaging indicates that only personnel familiar with electrical engineering are allowed to install and operate the product. WARNING: The connectors may not be plugged in or disconnected under load. Ignoring the warning or improper use may damage persons and/or property. • The products are suitable for applications in plant, controller, and electrical device engineering. • Assembled products may not be manipulated or improperly opened. • Only use mating connectors that are specified in the technical data of the standards listed (e.g. the ones listed in the product accessories online at phoenixcontact.com/products). • When using the product in direct connection with third-party manufacturers, the user is responsible. • For operating voltages > 50 V AC, conductive connector housings must be grounded • Ensure that the protective or functional ground has been properly connected. • Observe the corresponding technical data. You will find information: <ul style="list-style-type: none"> o On the product o On the packing label o In the supplied documentation o Online at phoenixcontact.com/products under the product • The installation notes/Design In documents online on the download page at phoenixcontact.com/products must be observed for this product. • Use a protective cap to protect connectors that are not in use. The suitable accessories are available online in the accessory section of the product at phoenixcontact.com/products • The connector warms up in normal operation. Depending on the ambient conditions, the surface of the connector can continue to warm up. In this case, the user is responsible for posting warnings (e.g. DIN EN ISO 13732-1:2008-12). • Operate the connector only when it is fully plugged in and interlocked. • Ensure that when laying the cable, the tensile load on the connectors does not exceed the upper limit specified in the standards.
--------------------	---

PV-FT-C2F-HSG - Photovoltaic connector



1704926

<https://www.phoenixcontact.com/us/products/1704926>

- Observe the minimum bending radius of the cable. Lay the cable without twisting it.

Product properties

Product type	Panel feed-through
Product family	SUNCLIX
Number of positions	1

Insulation characteristics

Protection class	II
Degree of pollution	3

Connection data

Conductor connection

Tightening torque	1.8 Nm \pm 0.1 Nm
-------------------	---------------------

Dimensions

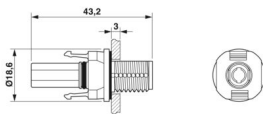
Dimensional drawing	
Width	18.6 mm
Height	18.6 mm
Length	43.2 mm

Electrical properties

Rated voltage (III/2)	1000 V
Rated voltage	1000 V DC (II/2.00) in accordance with IEC 62852:2014/AMD1:2 020
Rated surge voltage	16 kV
Rated surge voltage (III/2)	12 kV
Rated current (6.0 mm ²)	40 A (in accordance with IEC 62852:2014/AMD1:2020)
Rated current (4.0 mm ²)	35 A (in accordance with IEC 62852:2014/AMD1:2020)
Rated current (2.5 mm ²)	27 A (in accordance with IEC 62852:2014/AMD1:2020)
Contact resistance	< 0.45 m Ω (depending on the mating connector used)

Mechanical properties

Mechanical data

Insertion/withdrawal cycles	100
Insertion force	45 N \pm 10 N (with installed contacts)
Withdrawal force	250 N \pm 50 N (when locked)

Material specifications

PV-FT-C2F-HSG - Photovoltaic connector



1704926

<https://www.phoenixcontact.com/us/products/1704926>

Color	black
Color of the housing part	black
Material Housing	PPE
Material Contact carrier	PPE
Material Contact	Cu
Material Seal	EPDM
Material Contact surface	Ag
Material	Silopren (O-ring)
Flammability rating according to UL 94	V0
Insulating material group	III
Insulating material	mPPE

Cable/line

Cable pull-out force	> 80 N
----------------------	--------

Environmental and real-life conditions

Ambient conditions

Degree of protection	IP66/IP68 (2 m / 24 h) (plugged in) IP20 (Not plugged in) IP66/IP68 (2 m / 24 h)
Ambient temperature (operation) (male connector/female connector)	-40 °C ... 85 °C
Ambient temperature (assembly)	-25 °C ... 50 °C

Standards and regulations

Standards/specifications	IEC 62852:2014/AMD1:2020
--------------------------	--------------------------

PV-FT-C2F-HSG - Photovoltaic connector

1704926

<https://www.phoenixcontact.com/us/products/1704926>



Drawings

Dimensional drawing

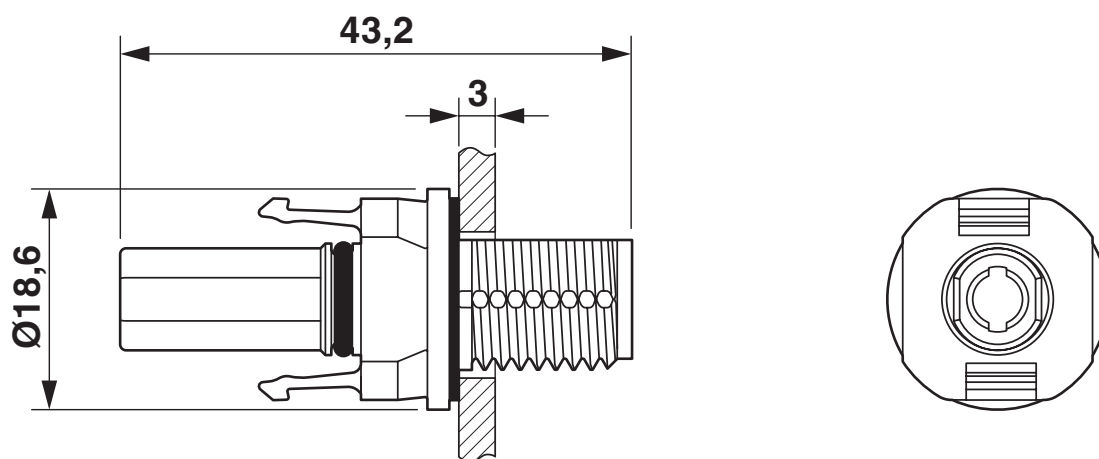

PV-FT-C2F-HSG - Photovoltaic connector



1704926

<https://www.phoenixcontact.com/us/products/1704926>

Approvals

To download certificates, visit the product detail page: <https://www.phoenixcontact.com/us/products/1704926>



TÜV Rheinland

Approval ID: R 60165003-0001

PV-FT-C2F-HSG - Photovoltaic connector



1704926

<https://www.phoenixcontact.com/us/products/1704926>

Classifications

ECLASS

ECLASS-13.0	27440107
ECLASS-15.0	27440107

ETIM

ETIM 10.0	EC002635
-----------	----------

UNSPSC

UNSPSC 21.0	39121400
-------------	----------

PV-FT-C2F-HSG - Photovoltaic connector



1704926

<https://www.phoenixcontact.com/us/products/1704926>

Environmental product compliance

EU RoHS

Fulfills EU RoHS substance requirements	Yes, No exemptions
---	--------------------

China RoHS

Environment friendly use period (EFUP)	EFUP-E
	No hazardous substances above the limits

EU REACH SVHC

REACH candidate substance (CAS No.)	Triphenyl phosphate(CAS: 115-86-6)
-------------------------------------	------------------------------------

Phoenix Contact 2026 © - all rights reserved
<https://www.phoenixcontact.com>

Phoenix Contact USA
586 Fulling Mill Road
Middletown, PA 17057, United States
(+717) 944-1300
info@phoenixcon.com