

# SACB-4/ 8-M23 SH - Distributor box

1695757

<https://www.phoenixcontact.com/us/products/1695757>

Please be informed that the data shown in this PDF document is generated from our online catalog. Please find the complete data in the user documentation. Our general terms of use for downloads are valid.



The figure shows a version with 8 slots

Distributor box, application: Standard, connection method: M12 socket Metal, number of slots: 4, number of positions: 5, coding: A, slot assignment: Double, status display: no, Universal; master cable connection: M23 plug connection 90°, shielding: yes

## Your advantages

- Safety in the field, thanks to molded housing and high degree of protection
- Save space: distributor box with double occupancy for two sensors in one slot
- Reliable signal transmission – 360° shielding in environments with electromagnetic interference

## Commercial data

Item number	1695757
Packing unit	1 pc
Note	Made to order (non-returnable)
Sales key	BF43
Product key	AF3CDB
GTIN	4017918899394
Weight per piece (including packing)	298.9 g
Weight per piece (excluding packing)	295.8 g
Customs tariff number	85366990
Country of origin	PL

# SACB-4/ 8-M23 SH - Distributor box



1695757

<https://www.phoenixcontact.com/us/products/1695757>

## Technical data

### Notes

Assembly note	<b>NOTE:</b> Observe the permissible bending radii when routing cables, since the degree of protection may be at risk if the bending forces are too high. Reduce mechanical loads upstream of the connector, e.g., by using cable ties.
Note on application	Unused slots are to be sealed off prior to commissioning. Suitable sealing elements are to be found under "Accessories".

### Product properties

Product type	Distributor box
Application	Standard
Number of positions	5
Number of slots	4
Coding	A
LED	no

### Electrical properties

Nominal voltage $U_N$	48 V AC
	60 V DC
Rated current, total	12 A
Max. current carrying capacity per path	2 A
Current carrying capacity per slot	4 A

### Connection data

#### Conductor connection

Sensor/actuator connection system	M12 socket
Tightening torque slot sensor/actuator cable	0.4 Nm

#### Connection assignment

Slot/position = Wire color or connection	1 / 4 (A) = 15
	1 / 2 (B) = 7
	2 / 4 (A) = 5
	2 / 2 (B) = 4
	3 / 4 (A) = 16
	3 / 2 (B) = 8
	4 / 4 (A) = 3
	4 / 2 (B) = 14
	1-4 / 1 (+ 48 V) = 19
	1-4 / 3 (0 V) = 6
1-4 / 5 (PE) = 12	

### Signaling

# SACB-4/ 8-M23 SH - Distributor box

1695757

<https://www.phoenixcontact.com/us/products/1695757>

Status display present	no
------------------------	----

## Dimensions

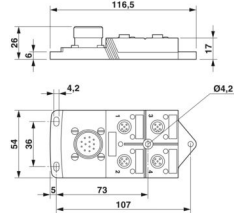
Dimensional drawing	
Width	61 mm
Height	31 mm
Length	117 mm

## Material specifications

Material Threaded sleeve	Aluminum
Material Housing	Aluminum
Material Molding compound	PUR
Flammability rating according to UL 94	V0
Seal material O-ring	NBR
Contact material	Cu alloy
Contact surface material	gold-plated
Contact carrier material	PA
Material of contact, master cable side	CU alloy
Material of the contact carrier on the master cable side	PA 6.6 V0
Material of contact surface, master cable side	gold-plated

## Cable/line

Connection method	M23 plug connection
-------------------	---------------------

## Environmental and real-life conditions

### Ambient conditions

Degree of protection	IP65
	IP67
Ambient temperature (operation)	-25 °C ... 70 °C

## Standards and regulations

Standard designation	M12 connector
Standards/specifications	IEC 61076-2-101

# SACB-4/ 8-M23 SH - Distributor box



1695757

<https://www.phoenixcontact.com/us/products/1695757>

## Drawings

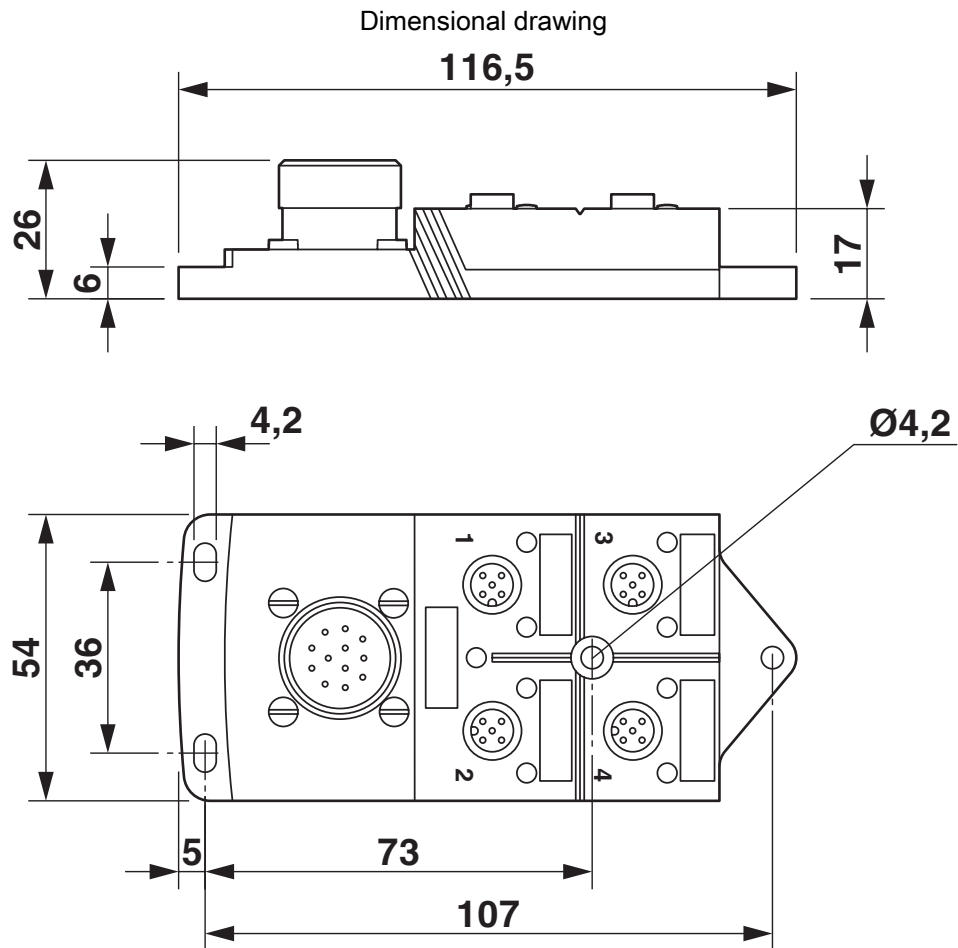

# SACB-4/ 8-M23 SH - Distributor box

1695757

<https://www.phoenixcontact.com/us/products/1695757>

Schematic diagram



M12 slot, socket, 5-pos.

Schematic diagram



M23 plug connection pin, 19-pos.

# SACB-4/ 8-M23 SH - Distributor box



1695757

<https://www.phoenixcontact.com/us/products/1695757>

Circuit diagram

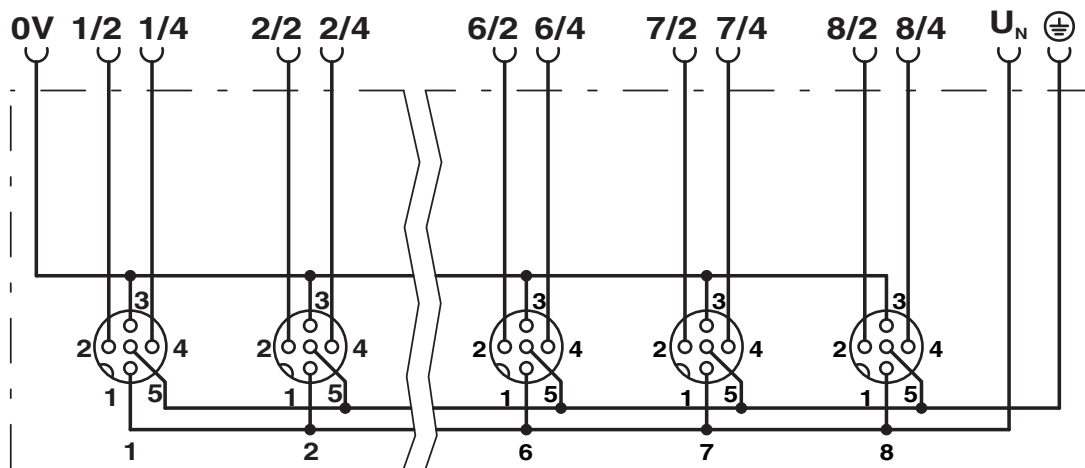

# SACB-4/ 8-M23 SH - Distributor box



1695757

<https://www.phoenixcontact.com/us/products/1695757>

## Classifications

### ECLASS

ECLASS-13.0	27440111
ECLASS-15.0	27440111

### UNSPSC

UNSPSC 21.0	31251501
-------------	----------

# SACB-4/ 8-M23 SH - Distributor box



1695757

<https://www.phoenixcontact.com/us/products/1695757>

## Environmental product compliance

### EU RoHS

Fulfills EU RoHS substance requirements	Yes
Exemption	6(a), 6(a)-I

### China RoHS

Environment friendly use period (EFUP)	EFUP-50
	An article-related China RoHS declaration table can be found in the download area for the respective article under "Manufacturer declaration". For all articles with EFUP-E, no China RoHS declaration table issued and required.

### EU REACH SVHC

REACH candidate substance (CAS No.)	Lead(CAS: 7439-92-1)
-------------------------------------	----------------------

Phoenix Contact 2026 © - all rights reserved  
<https://www.phoenixcontact.com>

Phoenix Contact USA  
586 Fulling Mill Road  
Middletown, PA 17057, United States  
(+717) 944-1300  
[info@phoenixcon.com](mailto:info@phoenixcon.com)