

SACB-8/ 8-L-10,0PUR - Distributor box



1695171

<https://www.phoenixcontact.com/us/products/1695171>

Please be informed that the data shown in this PDF document is generated from our online catalog. Please find the complete data in the user documentation. Our general terms of use for downloads are valid.



Distributor box, number of positions: 4, coding: A, status display: yes, PNP

Your advantages

- Safety in the field, thanks to robust housing and high degree of protection
- Convenient: increased machine availability thanks to quick and easy diagnostics

Commercial data

| | |
|--------------------------------------|--------------------------------|
| Item number | 1695171 |
| Packing unit | 1 pc |
| Note | Made to order (non-returnable) |
| Sales key | NULL |
| Product key | AF3CBA |
| GTIN | 4017918177652 |
| Weight per piece (including packing) | 1,206.3 g |
| Weight per piece (excluding packing) | 1,206.3 g |
| Customs tariff number | 85444290 |
| Country of origin | PL |

SACB-8/ 8-L-10,0PUR - Distributor box



1695171

<https://www.phoenixcontact.com/us/products/1695171>

Technical data

Product properties

| | |
|---------------------|-----------------|
| Product type | Distributor box |
| Number of positions | 4 |
| Coding | A |

Electrical properties

| | |
|-----------------------|---------|
| Nominal voltage U_N | 24 V DC |
|-----------------------|---------|

Signaling

| | |
|------------------------|-----|
| Status display present | yes |
|------------------------|-----|

Dimensions

| | |
|---------------------|--------|
| Dimensional drawing | |
| Width | 54 mm |
| Height | 19 mm |
| Length | 127 mm |

Material specifications

| | |
|--|-------|
| Flammability rating according to UL 94 | V0 |
| Contact material | CuSn |
| Contact surface material | Ni/Au |
| Contact carrier material | PA |

Environmental and real-life conditions

Ambient conditions

| | |
|---------------------------------|------------------|
| Degree of protection | IP65 |
| | IP67 |
| Ambient temperature (operation) | -25 °C ... 75 °C |

SACB-8/ 8-L-10,0PUR - Distributor box

1695171

<https://www.phoenixcontact.com/us/products/1695171>

Drawings

Dimensional drawing

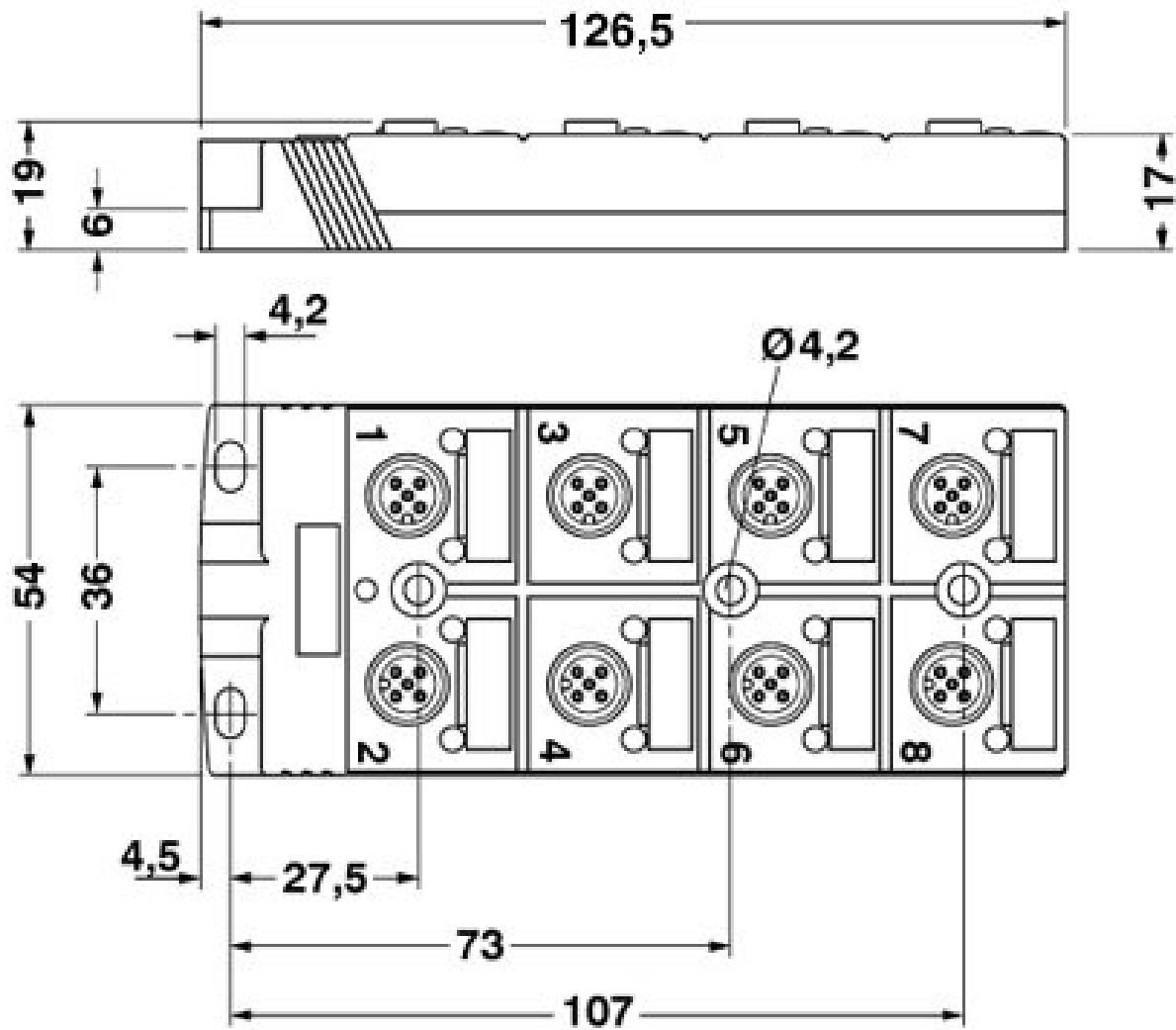

SACB-8/ 8-L-10,0PUR - Distributor box

1695171

<https://www.phoenixcontact.com/us/products/1695171>

Schematic diagram

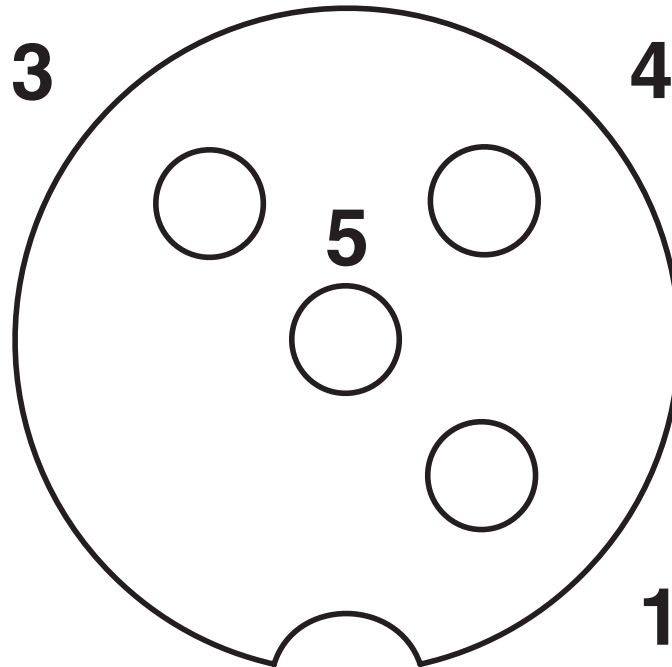

M12 slot, socket, 4-pos.

Circuit diagram

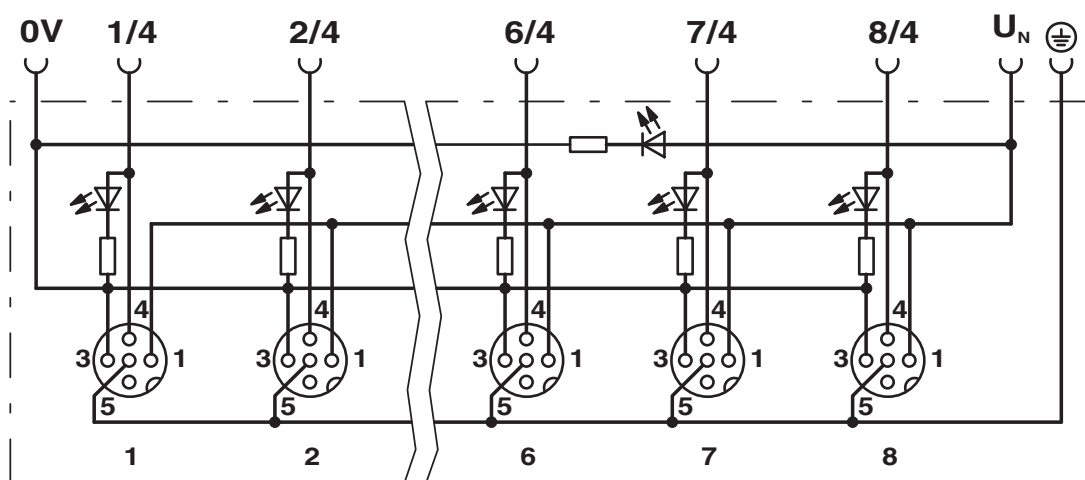

SACB-8/ 8-L-10,0PUR - Distributor box



1695171

<https://www.phoenixcontact.com/us/products/1695171>

Classifications

ECLASS

| | |
|-------------|----------|
| ECLASS-13.0 | 27440108 |
| ECLASS-15.0 | 27440108 |

SACB-8/ 8-L-10,0PUR - Distributor box



1695171

<https://www.phoenixcontact.com/us/products/1695171>

Environmental product compliance

EU REACH SVHC

| REACH candidate substance (CAS No.) | No substance above 0.1 wt% |
|-------------------------------------|----------------------------|
|-------------------------------------|----------------------------|

Phoenix Contact 2026 © - all rights reserved

<https://www.phoenixcontact.com>

Phoenix Contact USA
586 Fulling Mill Road
Middletown, PA 17057, United States
(+717) 944-1300
info@phoenixcon.com