

VS-15-KU-ST/ST - D-SUB coupling



1689666

<https://www.phoenixcontact.com/us/products/1689666>

Please be informed that the data shown in this PDF document is generated from our online catalog. Please find the complete data in the user documentation. Our general terms of use for downloads are valid.

D-SUB coupling, shell size 2, pin, gender changer, shielded, connection direction straight, IP67 degree of protection



Commercial data

Item number	1689666
Packing unit	1 pc
Note	Made to order (non-returnable)
Sales key	AB19
Product key	ABNCBC
GTIN	4017918920388
Weight per piece (including packing)	25.74 g
Weight per piece (excluding packing)	24.71 g
Customs tariff number	85366990
Country of origin	DE

VS-15-KU-ST/ST - D-SUB coupling



1689666

<https://www.phoenixcontact.com/us/products/1689666>

Technical data

Notes

Safety note

Safety note

WARNING: The connectors may not be plugged in or disconnected under load. Ignoring the warning or improper use may damage persons and/or property.

- WARNING: Commission properly functioning products only. The products must be regularly inspected for damage. Decommission defective products immediately. Replace damaged products. Repairs are not possible.

- WARNING: Only electrically qualified personnel may install and operate the product. They must observe the following safety notes. The qualified personnel must be familiar with the basics of electrical engineering. They must be able to recognize and prevent danger. The relevant symbol on the packaging indicates that only personnel familiar with electrical engineering are allowed to install and operate the product.

- The products are suitable for applications in plant, controller, and electrical device engineering.

- When operating the connectors in outdoor applications, they must be separately protected against environmental influences.

- Assembled products may not be manipulated or improperly opened.

- Only use mating connectors that are specified in the technical data of the standards listed (e.g. the ones listed in the product accessories online at [phoenixcontact.com/products](https://www.phoenixcontact.com/products)).

- When using the product in direct connection with third-party manufacturers, the user is responsible.

- For operating voltages > 50 V AC, conductive connector housings must be grounded

- Only use tools recommended by Phoenix Contact

- The installation notes/Design In documents online on the download page at [phoenixcontact.com/products](https://www.phoenixcontact.com/products) must be observed for this product.

- Use a protective cap to protect connectors that are not in use. The suitable accessories are available online in the accessory section of the product at [phoenixcontact.com/products](https://www.phoenixcontact.com/products)

- Operate the connector only when it is fully plugged in and interlocked.

- Operate the connector only when it is fully plugged in.

- Ensure that when laying the cable, the tensile load on the connectors does not exceed the upper limit specified in the standards.

- Observe the minimum bending radius of the cable. Lay the cable without twisting it.

- VDE 0100/1.97 § 411.1.3.2 and DIN EN 60 204/11.98 § 14.1.3 are applicable when combining several circuits in a cable and/or connector

Product properties

VS-15-KU-ST/ST - D-SUB coupling

1689666

<https://www.phoenixcontact.com/us/products/1689666>

Product type	Data plug
Type	D-SUB
Number of positions	15
Shielded	no
Cable outlet	straight

Insulation characteristics

Overvoltage category	III
Degree of pollution	2

Electrical properties

Rated voltage (III/3)	125 V
Rated current	5 A

Connection data

Connection method	D-SUB
-------------------	-------

Interfaces

Signal type/category	Universal
----------------------	-----------

Dimensions

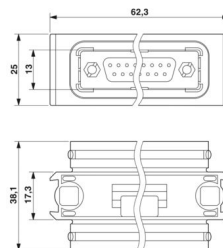
Dimensional drawing	
Width	38.1 mm
Height	25 mm
Length	62.3 mm

Material specifications

Color	gray
Flammability rating according to UL 94	V0
Seal material	EPDM
Housing material	Metal
Contact material	Copper alloy
Contact surface material	Hard gold-plated over nickel
Contact carrier material	Polyester GF

Cable/line

Signal type/category	Universal
----------------------	-----------

Mechanical properties

VS-15-KU-ST/ST - D-SUB coupling



1689666

<https://www.phoenixcontact.com/us/products/1689666>

Mechanical data

Insertion/withdrawal cycles	≥ 200
-----------------------------	-------

Environmental and real-life conditions

Ambient conditions

Degree of protection	IP67
Ambient temperature (operation)	-40 °C ... 80 °C

VS-15-KU-ST/ST - D-SUB coupling

1689666

<https://www.phoenixcontact.com/us/products/1689666>

Drawings

Dimensional drawing

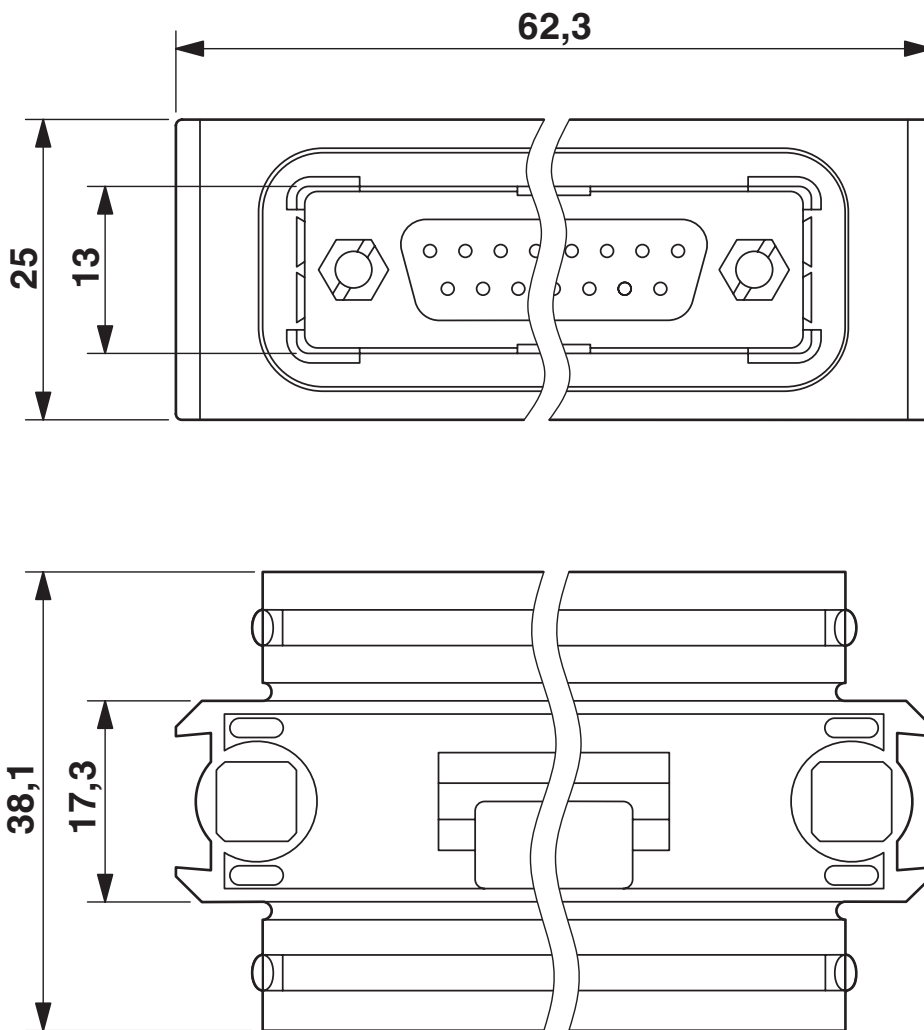

D-SUB coupling

VS-15-KU-ST/ST - D-SUB coupling



1689666

<https://www.phoenixcontact.com/us/products/1689666>

Classifications

ECLASS

ECLASS-13.0	27440210
ECLASS-15.0	27440210

UNSPSC

UNSPSC 21.0	39121400
-------------	----------

VS-15-KU-ST/ST - D-SUB coupling



1689666

<https://www.phoenixcontact.com/us/products/1689666>

Environmental product compliance

EU RoHS

Fulfills EU RoHS substance requirements	Yes, No exemptions
---	--------------------

China RoHS

Environment friendly use period (EFUP)	EFUP-E
	No hazardous substances above the limits

EU REACH SVHC

REACH candidate substance (CAS No.)	6,6'-di-tert-butyl-2,2'-methylenedi-p-cresol(CAS: 119-47-1)
-------------------------------------	---

Phoenix Contact 2026 © - all rights reserved
<https://www.phoenixcontact.com>

Phoenix Contact USA
586 Fulling Mill Road
Middletown, PA 17057, United States
(+717) 944-1300
info@phoenixcon.com