

# HC-B-AF - Panel-mount flange

1686533

<https://www.phoenixcontact.com/us/products/1686533>



Please be informed that the data shown in this PDF document is generated from our online catalog. Please find the complete data in the user documentation. Our general terms of use for downloads are valid.

Panel-mount flange for HEAVYCON ADVANCE housing



## Commercial data

Item number	1686533
Packing unit	20 pc
Minimum order quantity	20 pc
Sales key	BF66
Product key	AF7APZ
GTIN	4017918194345
Weight per piece (including packing)	11 g
Weight per piece (excluding packing)	9.865 g
Customs tariff number	85389099
Country of origin	CN

# HC-B-AF - Panel-mount flange

1686533

<https://www.phoenixcontact.com/us/products/1686533>

## Technical data

### Product properties

Product type	Panel-mount flange
Housing type	Panel-mount flange
Type	B6 - B24
Pg screw connection	none

### Connection data

Tightening torque	0.8 Nm ... 1.2 Nm (For M4 mounting screws on the panel-mount base)
-------------------	--

### Dimensions

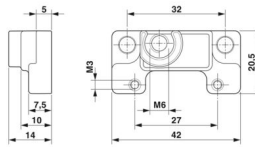
Dimensional drawing	
Width	42 mm
Height	20.5 mm
Depth	14 mm
Hole diameter	4.5 mm

### Material specifications

Material	Die-cast aluminum
----------	-------------------

### Mechanical properties

#### Mechanical data

Locking type	Nut
--------------	-----

### Environmental and real-life conditions

#### Ambient conditions

Ambient temperature (operation)	-40 °C ... 125 °C
---------------------------------	-------------------

### Mounting

Assembly note	<p>In order to guarantee that the protective conductor contact functions even when plugged in at an angle, the two panel-mount flanges must have sufficient electrical contact with the metal mounting panel.</p> <p>Minimum panel thickness of a steel sheet: 2.0 mm. For mounting with self-tapping M4 screws: 3.6 mm drill-hole diameter</p>
---------------	---

# HC-B-AF - Panel-mount flange

1686533

<https://www.phoenixcontact.com/us/products/1686533>



## Drawings

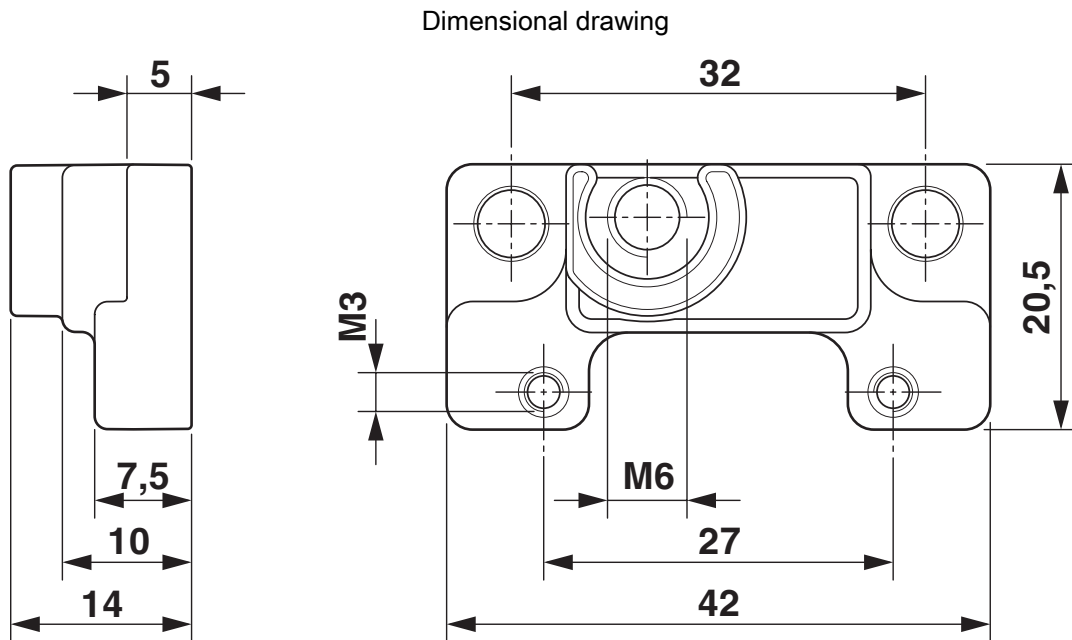

Dimensional drawing

# HC-B-AF - Panel-mount flange



1686533

<https://www.phoenixcontact.com/us/products/1686533>

## Approvals

To download certificates, visit the product detail page: <https://www.phoenixcontact.com/us/products/1686533>



**EAC**

Approval ID: RU C-DE.AI30.B.01102

# HC-B-AF - Panel-mount flange



1686533

<https://www.phoenixcontact.com/us/products/1686533>

## Classifications

### ECLASS

ECLASS-13.0	27440192
ECLASS-15.0	27440192

### ETIM

ETIM 10.0	EC002943
-----------	----------

### UNSPSC

UNSPSC 21.0	39121400
-------------	----------

# HC-B-AF - Panel-mount flange



1686533

<https://www.phoenixcontact.com/us/products/1686533>

## Environmental product compliance

### EU RoHS

Fulfills EU RoHS substance requirements	Yes, No exemptions
---	--------------------

### China RoHS

Environment friendly use period (EFUP)	EFUP-E
	No hazardous substances above the limits

### EU REACH SVHC

REACH candidate substance (CAS No.)	No substance above 0.1 wt%
-------------------------------------	----------------------------

Phoenix Contact 2026 © - all rights reserved  
<https://www.phoenixcontact.com>

Phoenix Contact USA  
586 Fulling Mill Road  
Middletown, PA 17057, United States  
(+717) 944-1300  
[info@phoenixcon.com](mailto:info@phoenixcon.com)