

# CK9,5-ED-16,00F AG - Crimp contact



1682085

<https://www.phoenixcontact.com/us/products/1682085>

Please be informed that the data shown in this PDF document is generated from our online catalog. Please find the complete data in the user documentation. Our general terms of use for downloads are valid.



Crimp contact, series: HC-M-...-70, Socket, turned, contact diameter: 9.5 mm, rated current: 200 A, connection cross section: 16 mm<sup>2</sup> ... 16 mm<sup>2</sup>, AWG 6...6 , contact material: Cu alloy

## Commercial data

Item number	1682085
Packing unit	1 pc
Minimum order quantity	1 pc
Sales key	BF65
Product key	AF7AIH
GTIN	4067923235595
Weight per piece (including packing)	31 g
Weight per piece (excluding packing)	30 g
Customs tariff number	85366990
Country of origin	DE

# CK9,5-ED-16,00F AG - Crimp contact



1682085

<https://www.phoenixcontact.com/us/products/1682085>

## Technical data

### Product properties

Product type	Crimp contact
Series	HC-M-...-70
Contact material type	turned

### Connection data

#### Connection technology

Contact connection type	Socket
Connection method	Crimp connection

#### Conductor connection

Stripping length	18.5 mm
Connection cross section	16 mm <sup>2</sup> ... 16 mm <sup>2</sup>
Connection cross section AWG	6 ... 6

### Material specifications

Material Contact	Cu alloy (lead-free)
Material Contact surface	Ag

### Dimensions

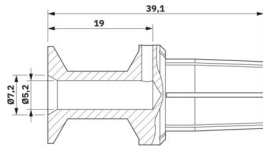
Dimensional drawing	
Length [l]	39.1 mm
Diameter (Contact diameter)	9.5 mm

### Electrical properties

Rated current	200 A (Take into account the derating of the contact insert used. The rated current corresponds to the maximum possible connection cross-section.)
---------------	--

### Mechanical properties

#### Mechanical data

Insertion/withdrawal cycles	≥ 500
-----------------------------	-------

### Environmental and real-life conditions

#### Ambient conditions

Ambient temperature (operation)	-40 °C ... 125 °C
---------------------------------	-------------------

# CK9,5-ED-16,00F AG - Crimp contact



1682085

<https://www.phoenixcontact.com/us/products/1682085>

## Drawings

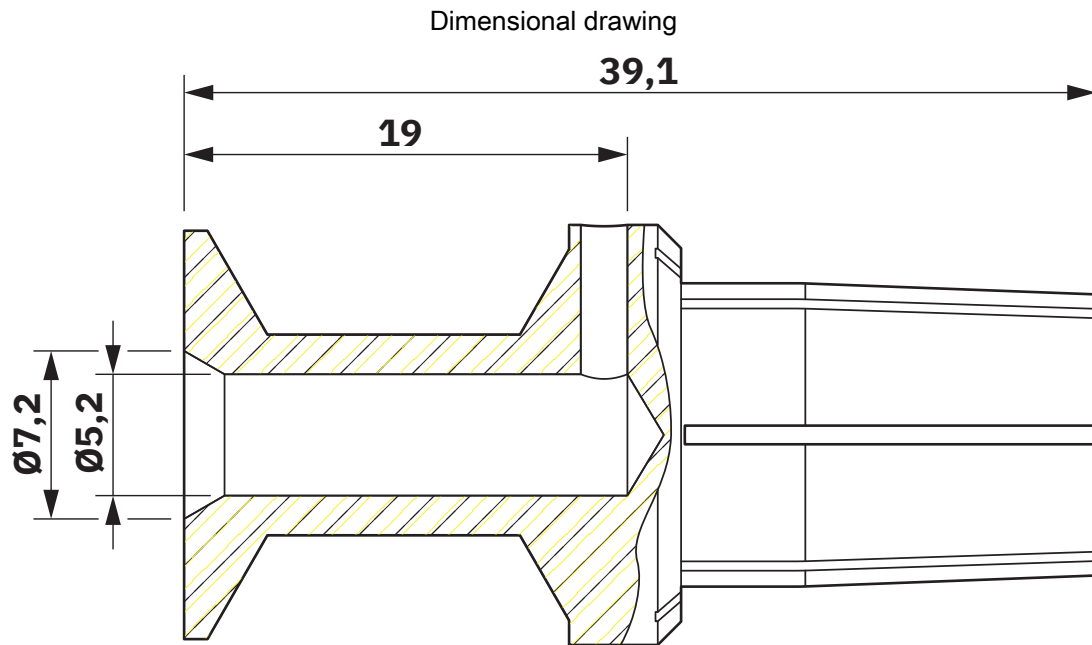

Dimensional drawing

# CK9,5-ED-16,00F AG - Crimp contact



1682085

<https://www.phoenixcontact.com/us/products/1682085>

## Classifications

### ECLASS

ECLASS-13.0	27440204
ECLASS-15.0	27440204

### ETIM

ETIM 10.0	EC000796
-----------	----------

### UNSPSC

UNSPSC 21.0	39121500
-------------	----------

# CK9,5-ED-16,00F AG - Crimp contact



1682085

<https://www.phoenixcontact.com/us/products/1682085>

## Environmental product compliance

### EU RoHS

Fulfills EU RoHS substance requirements	Yes, No exemptions
---	--------------------

### China RoHS

Environment friendly use period (EFUP)	EFUP-E
	No hazardous substances above the limits

### EU REACH SVHC

REACH candidate substance (CAS No.)	No substance above 0.1 wt%
-------------------------------------	----------------------------

Phoenix Contact 2026 © - all rights reserved  
<https://www.phoenixcontact.com>

Phoenix Contact USA  
586 Fulling Mill Road  
Middletown, PA 17057, United States  
(+717) 944-1300  
[info@phoenixcon.com](mailto:info@phoenixcon.com)